



2011

滾子軸受系列



滾輪軸受系列

Only export to

臺灣區總代理

惠祥貿易

軸受

BEARINGS OF 2011 TECHNOLOGY



In January 1958 Our Company
MINAMIGUCHI BEARING MFG.CO.,LTD.
In Osaka Japan, established by HIROMU MINAMIGUCHI.

Afterwards its production activities has been developed, enlarged and ball bearings commenced to be produced. It has always been our motto "HIGHER QUALITY & LOWER COST" as it is at present, through working hard constantly so as to enable us contribute to the industrial worked as well as to meet with the patronage of our customers.

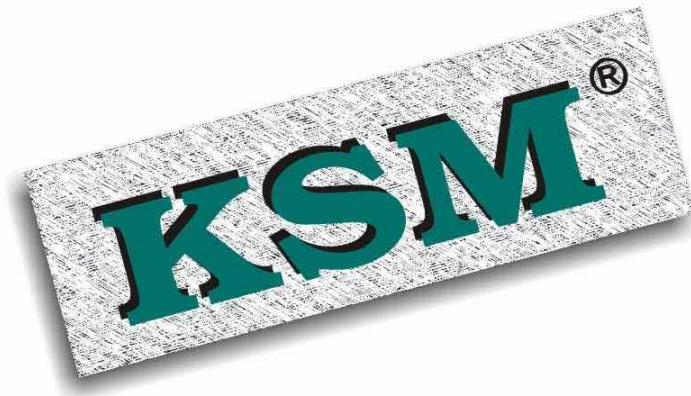

BEARINGS OF 2011 TECHNOLOGY



This **KSM** catalogue (needle roller bearings & track roller bearings) has been completely revised and contains considerable alternations and supplementary information compared to previous catalogue.

Products that are not shown may be available, but this should be checked in each case.

The **KSM** data in this catalogue are based on current production, in accordance with JISI standard.

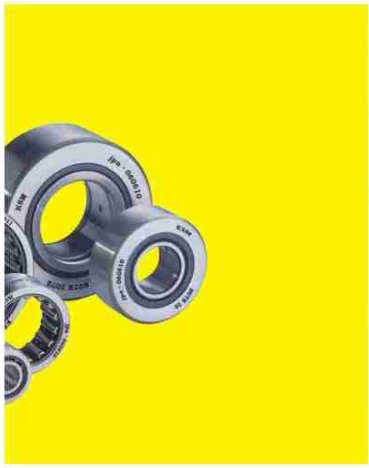

CONTENTS



Needle Roller Bearings

Pages 007 - 169



Track Roller Bearings

Pages 171 - 187

NEEDLE ROLLER BEARINGS

 **GENERAL TECHNICAL INFORMATION** T008 - 031

 **TECHNICAL SUPPLEMENT**

| | |
|---|------------|
| Needle roller and cage assemblies | T033 - 034 |
| Drawn cup needle roller bearings | T043 - 045 |
| One-way clutches | T053 - 054 |
| Machined-ring needle roller bearings | T057 - 059 |
| Machined-ring needle roller bearings, separable | T085 - 086 |
| Thrust roller bearings | T097 - 099 |
| Complex bearings | T105 - 107 |
| Roller followers | T117 - 120 |
| Cam followers | T131 - 133 |
| Components | T141 - 142 |
| Seals | T156 - 157 |

 **PRODUCT INFORMATION** P033 - 158

 **Needle roller and cage assemblies**

 K P035 - 042

 **Drawn cup needle roller bearings**

 HK P046 - 049

 BK P046 - 049

 HK..RS P050 - 051

 HK..2RS P050 - 051

 BK..RS P050 - 051

 **One-way clutches**

 HF P055

 HFL P056

 **Machined-ring needle roller bearings**

 NA 48, NA 49, NA 59 P060 - 067

 NA 69 ZW P060 - 067

 NA 49..RSR, RNA 49..RSR P068 - 069

 NA 49..2RSR, RNA 49..2RSR P068 - 069

 RNA 48, RNA 49
RNA 59 P070 - 077

 RNA 69 ZW P070 - 077

 NK P078 - 081

 NKI P082 - 083

 **Machined-ring needle roller bearings, separable**

 RNAO P088 - 091

 NAO P092 - 095

 **Thrust roller bearings**

 AXK 11 P100 - 101

 AS P100 - 101





 WS P100 - 101

 GS P100 - 101







 LS P102

 K 811, K 812 P103 - 104

 **Complex bearings**

| | | |
|---|---------------|------------|
|  | NKX, NKX..Z | P108 - 109 |
|  | NKXR, NKXR..Z | P110 - 111 |
|  | NKIA 59 | P112 - 113 |
|  | NKIB 59 | P114 - 115 |

 **Roller followers**

| | | |
|---|---------------|------------|
|  | NATR | P122 - 123 |
|  | NATR..PP | P122 - 123 |
|  | NATV | P124 - 125 |
|  | NATV..PP | P124 - 125 |
|  | NUTR | P126 - 127 |
|  | NA 22...2RSR | P128 - 129 |
|  | RNA 22...2RSR | P128 - 129 |

 **Cam followers**

| | | |
|---|------|------------|
|  | KR | P134 - 135 |
|  | KRV | P136 - 137 |
|  | NUKR | P138 - 139 |





 **Components**

| | | |
|---|----|------------|
|  | IR | P143 - 153 |
|---|----|------------|

 **Seals**

| | | |
|---|----|------------|
|  | G | P158 - 159 |
|  | SD | P158 - 159 |





 **Non-standard**

| | | |
|---|-------|------------|
|  | PWTR | P162 - 163 |
|  | PWKR | P164 - 165 |
|  | PWKRE | P166 - 167 |
|  | NUKRE | P168 - 169 |

TRACK ROLLER BEARINGS

 **TECHNICAL INFORMATION** T173 - 181

 **PRODUCT INFORMATION** P184 - 187

| | | |
|---|--------------------|------|
|  | LR 2..., LR 2..RRU | P184 |
|  | LR 52.. | P185 |
|  | LR 53.. | P186 |
|  | LFR..2Z, LFR..2RS | P187 |



KSM[®]



Needle Roller Bearings





TECHNICAL INFORMATION

T009 - 032

- | | |
|-------------------------------|------------|
| 1. Bearing materials | T009 |
| 2. Bearing tolerances | T009 - 012 |
| 3. Bearing fits | T013 - 018 |
| 4. Bearing internal clearance | T019 |
| 5. Lubrication | T019 - 022 |
| 6. Load rating and life | T023 - 029 |
| 7. Bearing handling | T029 - 032 |

1. Bearing materials

1.1 Raceway and rolling element materials

1.1.1 High/mid carbon alloy steel

In general, steel varieties which can be hardened not just on the surface but also deep hardened by the so-called "through hardening method" are used for the raceways and rolling elements of bearings. Foremost among these is high carbon chromium bearing steel, which is widely used.

1.1.2 Mid-carbon chromium steel

Mid-carbon chromium steel incorporating silicone and manganese, which gives it hardening properties comparable to high carbon chromium steel.

1.2 Cage materials

Bearing cage materials must have the strength to withstand rotational vibrations and shock loads. These materials must also have a low friction coefficient, be light weight, and be able to withstand bearing operation temperatures.

1.2.1 Pressed cages

For small and medium sized bearings, pressed cages of cold or hot rolled steel with a low carbon content of approx. 0.1% are used. However, depending on the application, austenitic stainless steel is also used.

1.2.2 Plastic cages

Injection molded plastic cages are now widely used; most are made from fiber glass reinforced heat resistant polyamide resin. Plastic cages are light weight, corrosion resistant and have excellent dampening and sliding properties. Heat resistant polyamide resins now enable the production of cages that perform well in applications ranging between -40 °C -120 °C. However, they are not recommended for use at temperatures exceeding 120 °C.

2. Bearing tolerances

2.1 Standard of tolerances

Ball bearing "tolerances" or dimensional accuracy and running accuracy, are regulated by ISO standard (rolling bearing tolerances). For dimensional accuracy, these standards prescribe the tolerances necessary when installing bearings on shafts or in housings. Running accuracy is defined as the allowable limits for bearing runout during operation.

Table 2.1 Bearings types and applicable tolerance

| Bearing type | | Applicable standard | Applicable tolerance class | | | | Applicable table |
|---|----------------|--------------------------------------|----------------------------|--------------------|--------------------|--------------------|------------------|
| Needle roller bearing | | ISO 492 (KSM standard) | class change | class 6 | class 5 | class 4 | Table 3.2 |
| Complex bearing | Radial bearing | | class 0 | class 6 | class 5 | — | Table 3.2 |
| | Thrust bearing | | KSM class 0 | KSM class 6 | KSM class 5 | KSM class 4 | Table 3.3 |
| Needle roller bearing with double-direction thrust roller bearing | Radial bearing | | — | — | class 5 | class 4 | Table 3.2 |
| | Thrust bearing | | — | — | KSM class 5 | KSM class 4 | Table 3.3 |
| Thrust roller bearings | | | KSM class 0 | KSM class 6 | KSM class 5 | KSM class 4 | Table 3.3 |
| Roller follower/cam follower | | | class 0 | — | — | — | Table 3.2 |

Table 2.2 Tolerance for radial bearings

Table 2.2.1 Inner rings

| Nominal bore diameter | | Single plane mean bore diameter deviation | | | | | | | | Single radial plane bore diameter variation | | | | Mean single plane bore diameter variation | | | | Inner ring radial runout | | | |
|-----------------------|-------|---|-----|---------|-----|---------|-----|----------------------|-----|---|---------|---------|---------|---|---------|---------|---------|--------------------------|---------|---------|---------|
| d | | Δd_{mp} | | | | | | | | V_{dp} | | | | V_{dmp} | | | | K_{ia} | | | |
| mm | | class 0 | | class 6 | | class 5 | | class 4 ¹ | | class 0 | class 6 | class 5 | class 4 | class 0 | class 6 | class 5 | class 4 | class 0 | class 6 | class 5 | class 4 |
| over | incl. | high | low | high | low | high | low | high | low | max. | | | | max. | | | | max. | | | |
| 2.5 ² | 10 | 0 | -8 | 0 | -7 | 0 | -5 | 0 | -4 | 10 | 9 | 5 | 4 | 6 | 5 | 3 | 2.0 | 10 | 6 | 4 | 2.5 |
| 10 | 18 | 0 | -8 | 0 | -7 | 0 | -5 | 0 | -4 | 10 | 9 | 5 | 4 | 6 | 5 | 3 | 2.0 | 10 | 7 | 4 | 2.5 |
| 18 | 30 | 0 | -10 | 0 | -8 | 0 | -6 | 0 | -5 | 13 | 10 | 6 | 5 | 8 | 6 | 3 | 2.5 | 13 | 8 | 4 | 3.0 |
| 30 | 50 | 0 | -12 | 0 | -10 | 0 | -8 | 0 | -6 | 15 | 13 | 8 | 6 | 9 | 8 | 4 | 3.0 | 15 | 10 | 5 | 4.0 |
| 50 | 80 | 0 | -15 | 0 | -12 | 0 | -9 | 0 | -7 | 19 | 15 | 9 | 7 | 11 | 9 | 5 | 3.5 | 20 | 10 | 5 | 4.0 |
| 80 | 120 | 0 | -20 | 0 | -15 | 0 | -10 | 0 | -8 | 25 | 19 | 10 | 8 | 15 | 11 | 5 | 4.0 | 25 | 13 | 6 | 5.0 |
| 120 | 150 | 0 | -25 | 0 | -18 | 0 | -13 | 0 | -10 | 31 | 23 | 13 | 10 | 19 | 14 | 7 | 5.0 | 30 | 18 | 8 | 6.0 |
| 150 | 180 | 0 | -25 | 0 | -18 | 0 | -13 | 0 | -10 | 31 | 23 | 13 | 10 | 19 | 14 | 7 | 5.0 | 30 | 18 | 8 | 6.0 |
| 180 | 250 | 0 | -30 | 0 | -22 | 0 | -15 | 0 | -12 | 38 | 28 | 15 | 12 | 23 | 17 | 8 | 6.0 | 40 | 20 | 10 | 8.0 |
| 250 | 315 | 0 | -35 | 0 | -25 | 0 | -18 | — | — | 44 | 31 | 18 | — | 26 | 19 | 9 | — | 50 | 25 | 13 | — |
| 315 | 400 | 0 | -40 | 0 | -30 | 0 | -23 | — | — | 50 | 38 | 23 | — | 30 | 23 | 12 | — | 60 | 30 | 15 | — |
| 400 | 500 | 0 | -45 | 0 | -35 | — | — | — | — | 56 | 44 | — | — | 34 | 26 | — | — | 65 | 35 | — | — |

Note: ¹ The dimensional difference Δd of the bore diameter to be applied for class 4 is the same as the tolerance of dimensional difference Δd_{mp} of the average bore diameter

² Nominal bore diameter of bearings of 2.5 mm is included in this dimensional division.

(Unit: μm)

| Nominal bore diameter | | Face runout with bore | | | Inner ring axial runout (with side) | | | Inner ring width deviation | | | | Inner ring width variation | | | |
|-----------------------|-------|-----------------------|---------|---------|-------------------------------------|---------|---------|----------------------------|-----------|---------|---------|----------------------------|---------|----|-----|
| D | | S_d | | | S_{ia} ³ | | | ΔB_s | | | | V_{Bs} | | | |
| mm | | class 0 | class 6 | class 5 | class 0 | class 6 | class 5 | class 0,6 | class 5,4 | class 0 | class 6 | class 5 | class 4 | | |
| over | incl. | max. | | | max. | | | high | low | high | low | max. | | | |
| 2.5 ² | 10 | 7 | 3 | 1.5 | 7 | 3 | 1.5 | 0 | -120 | 0 | -40 | 15 | 15 | 5 | 2.5 |
| 10 | 18 | 7 | 3 | 1.5 | 7 | 3 | 1.5 | 0 | -120 | 0 | -80 | 20 | 20 | 5 | 2.5 |
| 18 | 30 | 8 | 4 | 1.5 | 8 | 4 | 2.5 | 0 | -120 | 0 | -120 | 20 | 20 | 5 | 2.5 |
| 30 | 50 | 8 | 4 | 1.5 | 8 | 4 | 2.5 | 0 | -120 | 0 | -120 | 20 | 20 | 5 | 3.0 |
| 50 | 80 | 8 | 5 | 1.5 | 8 | 5 | 2.5 | 0 | -150 | 0 | -150 | 25 | 25 | 6 | 4.0 |
| 80 | 120 | 9 | 5 | 2.5 | 9 | 5 | 2.5 | 0 | -200 | 0 | -200 | 25 | 25 | 7 | 4.0 |
| 120 | 150 | 10 | 6 | 2.5 | 10 | 7 | 2.5 | 0 | -250 | 0 | -250 | 30 | 30 | 8 | 5.0 |
| 150 | 180 | 10 | 6 | 4.0 | 10 | 7 | 5.0 | 0 | -250 | 0 | -250 | 30 | 30 | 8 | 5.0 |
| 180 | 250 | 11 | 7 | 5.0 | 13 | 8 | 5.0 | 0 | -300 | 0 | -300 | 30 | 30 | 10 | 6.0 |
| 250 | 315 | 13 | — | — | 15 | — | — | 0 | -350 | 0 | -350 | 35 | 35 | 13 | — |
| 315 | 400 | 15 | — | — | 20 | — | — | 0 | -400 | 0 | -400 | 40 | 40 | 15 | — |
| 400 | 500 | — | — | — | — | — | — | 0 | -450 | — | — | 50 | 45 | — | — |

Note: ³ To be applied for deep groove ball bearing.

Symbols: Δd_{mp} : deviation of the mean bore diameter from the nominal ($\Delta d_{mp} = d_{mp} - d$).

V_{dp} : bore diameter variation; difference between the largest and smallest single bore diameters in one plane.

V_{dmp} : mean bore diameter variation; difference between the largest and smallest mean bore diameters of one ring or washer.

K_{ia} : radial runout of assembled bearing inner ring and assembled bearing outer ring, respectively.

S_d : side face runout with reference to bore (of inner ring).

S_{ia} : side face runout of assembled bearing inner ring and assembled bearing outer ring, respectively.

ΔB_s : deviation of single inner ring width or single outer ring width from the nominal ($\Delta B_s = B_s - B$ etc.)

V_{Bs} : ring width variation; difference between the largest and smallest single widths of inner ring and of outer ring, respectively.



Table 2.2.2 Outer rings

| Nominal outside diameter | | Single plane mean outside diameter deviation | | | | | | | | Single radial plane outside diameter variation | | | | Mean single plane outside diameter variation | | | | Outer ring radial runout | | | |
|--------------------------|-------|--|-----|---------|-----|---------|-----|----------------------|-----|--|---------|---------|---------|--|---------|---------|---------|--------------------------|---------|---------|---------|
| D mm | | ΔD_{mp} | | | | | | | | V_{Dp} | | | | V_{Dmp} | | | | K_{ea} | | | |
| over | incl. | class 0 | | class 6 | | class 5 | | class 4 ^④ | | class 0 | class 6 | class 5 | class 4 | class 0 | class 6 | class 5 | class 4 | class 0 | class 6 | class 5 | class 4 |
| | | high | low | high | low | high | low | high | low | max. | | | | max. | | | | max. | | | |
| 6 ^⑤ | 18 | 0 | -8 | 0 | -7 | 0 | -5 | 0 | -4 | 10 | 9 | 5 | 4 | 6 | 5 | 3 | 2.0 | 15 | 8 | 5 | 3 |
| 18 | 30 | 0 | -9 | 0 | -8 | 0 | -6 | 0 | -5 | 12 | 10 | 6 | 5 | 7 | 6 | 3 | 2.5 | 15 | 9 | 6 | 4 |
| 30 | 50 | 0 | -11 | 0 | -9 | 0 | -7 | 0 | -6 | 14 | 11 | 7 | 6 | 8 | 7 | 4 | 3.0 | 20 | 10 | 7 | 5 |
| 50 | 80 | 0 | -13 | 0 | -11 | 0 | -9 | 0 | -7 | 16 | 14 | 9 | 7 | 10 | 8 | 5 | 3.5 | 25 | 13 | 8 | 5 |
| 80 | 120 | 0 | -15 | 0 | -13 | 0 | -10 | 0 | -8 | 19 | 16 | 10 | 8 | 11 | 10 | 5 | 4.0 | 35 | 18 | 10 | 6 |
| 120 | 150 | 0 | -18 | 0 | -15 | 0 | -11 | 0 | -9 | 23 | 19 | 11 | 9 | 14 | 11 | 6 | 5.0 | 40 | 20 | 11 | 7 |
| 150 | 180 | 0 | -25 | 0 | -18 | 0 | -13 | 0 | -10 | 31 | 23 | 13 | 10 | 19 | 14 | 7 | 5.0 | 45 | 23 | 13 | 8 |
| 180 | 250 | 0 | -30 | 0 | -20 | 0 | -15 | 0 | -11 | 38 | 25 | 15 | 11 | 23 | 15 | 8 | 6.0 | 50 | 25 | 15 | 10 |
| 250 | 315 | 0 | -35 | 0 | -25 | 0 | -18 | 0 | -13 | 44 | 31 | 18 | 13 | 26 | 19 | 9 | 7.0 | 60 | 30 | 18 | 11 |
| 315 | 400 | 0 | -40 | 0 | -28 | 0 | -20 | 0 | -15 | 50 | 35 | 20 | 15 | 30 | 21 | 10 | 8.0 | 70 | 35 | 20 | 13 |
| 400 | 500 | 0 | -45 | 0 | -33 | 0 | -23 | — | — | 56 | 41 | 23 | — | 34 | 25 | 12 | — | 80 | 40 | 23 | — |
| 500 | 630 | 0 | -50 | 0 | -38 | 0 | -28 | — | — | 63 | 48 | 28 | — | 38 | 29 | 14 | — | 100 | 50 | 25 | — |

Note: ^④ The dimensional difference ΔD_s of the outer diameter to be applied for class 4 is the same as the tolerance of dimensional difference ΔD_{mp} of the average outer diameter.

^⑤ Nominal outer diameter of bearings of 6 mm is included in this dimensional division.

(Unit: μm)

| Nominal outside diameter | | Outside surface inclination | | Outside ring axial runout | | Outer ring width deviation | | Outer ring width variation | | |
|--------------------------|-------|-----------------------------|---------|---------------------------|---------|----------------------------|--|----------------------------|---------|---------|
| D mm | | S_d | | S_{ia} ^⑥ | | ΔC_s | | V_{Cs} | | |
| over | incl. | class 5 | class 4 | class 5 | class 4 | all type | | class 0,6 | class 5 | class 4 |
| | | max. | | max. | | | | max. | | |
| 6 ^⑤ | 18 | 8 | 4 | 8 | 5 | | | | 5 | 2.5 |
| 18 | 30 | 8 | 4 | 8 | 5 | | | | 5 | 2.5 |
| 30 | 50 | 8 | 4 | 8 | 5 | | | | 5 | 2.5 |
| 50 | 80 | 8 | 4 | 10 | 5 | | | | 6 | 3.0 |
| 80 | 120 | 9 | 5 | 11 | 6 | Identical to | | Identical to | 8 | 4.0 |
| 120 | 150 | 10 | 5 | 13 | 7 | ΔB_s of inner | | ΔB_s and V_{bs} | 8 | 5.0 |
| 150 | 180 | 10 | 5 | 14 | 8 | ring of same | | of inner | 8 | 5.0 |
| 180 | 250 | 11 | 7 | 15 | 10 | bearing | | ring of same | 10 | 7.0 |
| 250 | 315 | 13 | 8 | 18 | 10 | | | bearing | 11 | 7.0 |
| 315 | 400 | 13 | 10 | 20 | 13 | | | | 13 | 8.0 |
| 400 | 500 | 15 | — | 23 | — | | | | 15 | — |
| 500 | 630 | 18 | — | 25 | — | | | | 18 | — |

Note: ^⑥ To be applied for deep groove ball bearings.

Symbols: ΔD_{mp} : deviation of the mean outside diameter from the nominal ($\Delta D_{mp} = D_{mp} - D$).

V_{Dp} : outside diameter variation; difference between the largest and smallest single outside diameters in one plane.

V_{Dmp} : mean bore diameter variation; difference between the largest and smallest mean bore diameters of one ring or washer.

K_{ea} : radial runout of assembled bearing inner ring and assembled bearing outer ring, respectively.

S_d : side face runout with reference to bore (of inner ring).

S_{ia} : side face runout of assembled bearing inner ring and assembled bearing outer ring, respectively.

ΔC_s : deviation of single inner ring width or single outer ring width from the nominal ($\Delta B_s = B_s - B$ etc.).

V_{Cs} : ring width variation; difference between the largest and smallest single widths of inner ring and of outer ring, respectively.



Table 2.3 Tolerance of thrust roller bearings

Table 2.3.1 Inner rings

(Unit: μm)

| Nominal outer diameter d mm | | Single plane mean bore diameter deviation Δd_{mp} | | | | Single radial plane bore diameter variation V_{dp} | | Thrust bearing shaft washer raceway (or center washer raceway) thickness variation S_i | | | |
|----------------------------------|-------|---|-----|---------|-----|--|---------|--|---------|---------|---------|
| over | incl. | class 0,6,5 | | class 4 | | class 0,6,5 | class 4 | class 0 | class 6 | class 5 | class 4 |
| | | high | low | high | low | max. | | | max. | | |
| — | 18 | 0 | -8 | 0 | -7 | 6 | 5 | 10 | 5 | 3 | 2 |
| 18 | 30 | 0 | -10 | 0 | -8 | 8 | 6 | 10 | 5 | 3 | 2 |
| 30 | 50 | 0 | -12 | 0 | -10 | 9 | 8 | 10 | 6 | 3 | 2 |
| 50 | 80 | 0 | -15 | 0 | -12 | 11 | 9 | 10 | 7 | 4 | 3 |
| 80 | 120 | 0 | -20 | 0 | -15 | 15 | 11 | 15 | 8 | 4 | 3 |
| 120 | 180 | 0 | -25 | 0 | -18 | 19 | 14 | 15 | 9 | 5 | 4 |
| 180 | 250 | 0 | -30 | 0 | -22 | 23 | 17 | 20 | 10 | 5 | 4 |
| 250 | 315 | 0 | -35 | 0 | -25 | 26 | 19 | 25 | 13 | 7 | 5 |
| 315 | 400 | 0 | -40 | 0 | -30 | 30 | 23 | 30 | 15 | 7 | 5 |
| 400 | 500 | 0 | -45 | 0 | -35 | 34 | 26 | 30 | 18 | 9 | 6 |
| 500 | 630 | 0 | -50 | 0 | -40 | 38 | 30 | 35 | 21 | 11 | 7 |

Table 2.3.2 Outer rings

(Unit: μm)

| Nominal outside diameter D mm | | Single plane mean outside diameter deviation ΔD_{mp} | | | | Single radial plane outside diameter variation V_{Dp} | | Thrust bearing housing washer raceway thickness variation S_e | | | |
|------------------------------------|-------|--|-----|---------|-----|---|---------|---|---------|---------|---------|
| over | incl. | class 0,6,5 | | class 4 | | class 0,6,5 | class 4 | class 0 | class 6 | class 5 | class 4 |
| | | high | low | high | low | max. | | | max. | | |
| 10 | 18 | 0 | -11 | 0 | -7 | 8 | 5 | | | | |
| 18 | 30 | 0 | -13 | 0 | -8 | 10 | 6 | | | | |
| 30 | 50 | 0 | -16 | 0 | -9 | 12 | 7 | | | | |
| 50 | 80 | 0 | -19 | 0 | -11 | 14 | 8 | | | | |
| 80 | 120 | 0 | -22 | 0 | -13 | 17 | 10 | | | | |
| 120 | 180 | 0 | -25 | 0 | -15 | 19 | 11 | | | | |
| 180 | 250 | 0 | -30 | 0 | -20 | 23 | 15 | | | | |
| 250 | 315 | 0 | -35 | 0 | -25 | 26 | 19 | | | | |
| 315 | 400 | 0 | -40 | 0 | -28 | 30 | 21 | | | | |
| 400 | 500 | 0 | -45 | 0 | -33 | 34 | 25 | | | | |
| 500 | 630 | 0 | -50 | 0 | -38 | 38 | 29 | | | | |
| 630 | 800 | 0 | -75 | 0 | -45 | 55 | 34 | | | | |

According to the tolerance of S_i against "d" or "d2" of the same bearings

Symbols: Δd_{mp} : deviation of the mean bore diameter from the nominal ($\Delta d_{mp} = d_{mp} - d$).

V_{dp} : bore diameter variation; difference between the largest and smallest single bore diameters in one plane.

S_i : thickness variation, measured from middle of raceway to back (seating) face of shaft washer and of housing washer, respectively (axial runout).

ΔD_{mp} : deviation of the mean outside diameter from the nominal ($\Delta D_{mp} = D_{mp} - D$).

V_{Dp} : outside diameter variation; difference between the largest and smallest single outside diameters in one plane.

S_e : thickness variation, measured from middle of raceway to back (seating) face of shaft washer and of housing washer, respectively (axial runout).



3. Bearing fits

3.1 Interference

For rolling bearings, inner and outer rings are fixed on the shaft or in the housing so that relative movement does not occur between fitted surfaces during operation or under load. This relative movement (referred to as "creep") between the fitted surfaces of the bearing and the shaft or housing can occur in a radial direction, an axial direction, or in the direction of rotation. To help prevent this creeping movement, bearing rings and the shaft or housing are installed with one of three interference fits, a "tight fit" (also called shrink fit), "transition fit," or "loose fit" (also called clearance fit), and the degree of interference between their fitted surfaces varies.

The most effective way to fix the fitted surfaces between a bearing's raceway and shaft or housing is to apply a "tight fit." The advantage of this tight fit for thin walled bearings is that it provides uniform load support over the entire ring circumference without any loss of load carrying capacity. However, with a tight fit, ease of installation and disassembly is lost, and when using a non-separable bearing as the floating-side bearing, axial displacement is not possible. For this reason, a tight fit cannot be recommended in all cases.

3.2 The necessity of a proper fit

In some cases, improper fit may lead to damage and shorten bearing life, therefore it is necessary to make a careful analysis in selecting a proper fit. Some of the negative conditions caused by improper fit are listed below.

- Raceway cracking, early peeling and displacement of raceway
- Raceway and shaft or housing abrasion caused by creeping and fretting corrosion
- Seizing caused by loss of internal clearances
- Increased noise and lowered rotational accuracy due to raceway groove deformation

3.3 Fit selection

Selection of a proper fit is dependent upon thorough analysis of bearing operating conditions, including consideration of:

- Shaft and housing material, wall thickness, finished surface accuracy, etc.
- Machinery operating conditions (nature and magnitude of load, rotational speed, temperature, etc.)

3.3.1 "Tight fit," "transition fit," or "loose fit"







For raceways under rotating loads, a tight fit is necessary. (Refer to Table 3.1)

"Raceways under rotating loads" refers to raceways receiving loads rotating relative to their radial direction. For raceways under static loads, on the other hand, a loose fit is sufficient. (Example) Rotating inner ring load - the direction of the radial load on the inner ring is rotating relatively

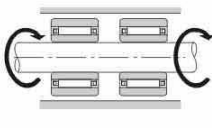
For non-separable bearings, such as deep groove ball bearings, it is generally recommended that either the inner ring or outer ring be given a loose fit.

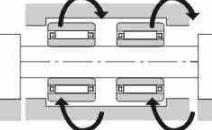

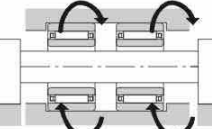
Table 3.1 Radial load for bearing

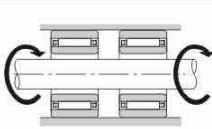
| Illustration | Bearing rotation | Ring load | Fit |
|--|--|--------------------------|-----------------------|
|  |  Inner ring: Rotating Outer ring: Stationary | Rotating inner ring load | Inner ring: Tight fit |
|  |  Inner ring: Stationary Outer ring: Rotating | Static outer ring load | Outer ring: Loose fit |
|  |  Inner ring: Stationary Outer ring: Rotating | Static inner ring load | Inner ring: Loose fit |
|  |  Inner ring: Rotating Outer ring: Stationary | Rotating outer ring load | Outer ring: Tight fit |

3.3.2 Recommended Fits

The system of limits and fits define the tolerances of the outside diameter of the shaft or the bore diameter of a housing (the shaft or housing to which a metric bearing is installed). Bearing fit is governed by the selection of tolerances for the shaft outside diameter and housing bore diameter. Fig. 3.1 summarizes the interrelations between shaft outside diameter and bearing bore diameter, and between housing bore diameter and shaft outside diameter. Table 3.2 provides the recommended fits for common radial needle roller bearings (machined ring needle roller bearings with inner ring), relative to dimensions and loading conditions. Table 3.3 is a table of the numerical value of fits.

3.3.3 Interference minimum and maximum values

The following points should be considered when it is necessary to calculate the interference for an application:

- In calculating the minimum required amount of interference keep in mind that:
 - 1) interference is reduced by radial loads
 - 2) interference is reduced by differences between bearing temperature and ambient temperature
 - 3) interference is reduced by variation of fitted surfaces
- Maximum interference should be no more than 1:1000 of the shaft diameter or outer diameter. Required interference calculations are shown below.

3.3.3.1 Fitted surface variation and required interference

Interference between fitted surfaces is reduced by roughness and other slight variations of these surfaces which are flattened in the fitting process. The degree of reduced interference depends upon the finish treatment of these surfaces, but in general it is necessary to assume the following interference reductions.

For ground shafts: 1.0 ~ 2.5 μm

For lathed shafts : 5.0 ~ 7.0 μm

3.3.3.2 Maximum interference

When bearing rings are installed with an interference fit, tension or compression stress may occur along their raceways. If interference is too great, this may cause damage to the rings and reduce bearing life. For these reasons, maximum interference should not exceed the previously mentioned ratio of 1:1000 of the shaft or outside diameter.

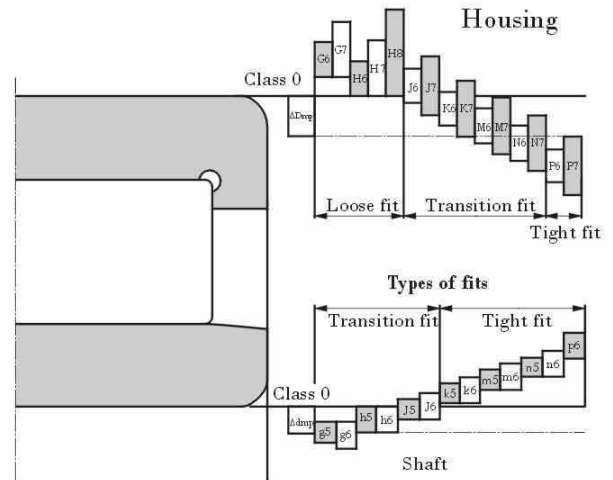

Fig. 4.1

Table 3.2 General standards for needle roller bearing fits

Table 3.2.1 Shaft fits

| Nature of load | Fit | Load condition, magnitude | Shaft diameter mm | | Tolerance class | Remarks |
|--|------------------------------|---|---------------------|------|-----------------|---|
| | | | over | incl | | |
| Indeterminate direction load Rotating inner ring load | Tight fit/ Transition fit | Light load ① | ~ 50 | 50 | js6 | When greater accuracy is required m5 may be substituted for m6. |
| | | | 50 ~ 100 | 100 | k6 | |
| | | | 100 ~ 200 | 200 | m6 | |
| | | Normal load ① | ~ 50 | 50 | k5 | |
| | | | 50 ~ 100 | 100 | m5 | |
| | | | 100 ~ 150 | 150 | n6 | |
| | | 200 ~ | 200 | p6 | | |
| | | Heavy load ① or shock load | ~ 150 | 150 | n6 | When greater accuracy is required m5 may be substituted for m6. |
| | | | ~ | | p6 | |
| Static inner ring load | Transition fit | Inner ring axial displacement possible | All shaft diameters | | g6 | When greater accuracy is required use g5. For large bearings, f6 may be used. |
| | | Inner ring axial displacement unnecessary | | | h6 | |
| Centric axial load only | Transition fit | All loads | All shaft diameters | | js6 | General; depending on the fit, shaft and inner rings are not fixed. |

① Standards for light loads, normal loads, and heavy loads

Light loads : equivalent radial load $\leq 0.06 C_r$

Normal loads: $0.06 C_r < \text{equivalent radial load} \leq 0.12 C_r$

Heavy loads : $0.12 C_r < \text{equivalent radial load}$

Note: All values and fits listed in the above tables are for solid steel shafts.



Table 3.2 .2 Housing fits (Housing of the drawn cup needle roller bearing.)

| Nature of load | Housing | Fit | Load condition, magnitude | Tolerance class | Outer ring axial displacement ② | Remarks |
|--|--------------------------------|-------------------------|--|--|---|---|
| Rotating outer ring load or static outer ring load | Solid housing or split housing | Loose fit | All loads | J7 | Displacement possible | G7 also acceptable for large type bearings as well as outer rings and housings with large temperature differences |
| | | | Light ^① to normal load | H7 | Displacement possible | — |
| | Solid housing | Transition or loose fit | High rotation accuracy required with light to normal loads | K6 | Displacement not possible (in principle) | Applies primarily to roller bearings |
| Tight to transition fit | | Light to normal load | J7 | Displacement possible | When greater accuracy is required substitute j6 for J7 and K6 for K7. | |
| | | Normal to heavy load | K7 | Displacement not possible (in principle) | | |
| | | Heavy shock load | M7 | Displacement not possible | | |
| Inner ring static load or outer ring rotating load | | Tight fit | Light or variable load | M7 | Displacement not possible | — |
| | | | Normal to heavy load | N7 | Displacement not possible | — |
| | | | Heavy load (thin wall housing) or heavy shock load | P7 | Displacement not possible | — |
| Centered axial load only - Loose fit | Loose fit | — | — | Select a tolerance class that will provide clearance between outer ring and housing. | — | |

① Standards for light loads, normal loads, and heavy loads

Light loads : equivalent radial load $\leq 0,06 C_r$

Normal loads: $0,06 C_r < \text{equivalent radial load} \leq 0,12 C_r$

Heavy loads : $0,12 C_r < \text{equivalent radial load}$

② Indicates whether or not outer ring axial displacement is possible with non-separable type bearings.

Note 1 : All values and fits listed in the above tables are for cast iron or steel housings.

2 : In cases where only a centered axial load acts on the bearing, select a tolerance class that will provide clearance in the axial direction for the outer ring.



Table 3.3 Numeric value table of fitting for radial bearing of class 0

Table 3.3.1 Fitting against shaft

| Nominal bore diameter of bearing | | Single plane mean bore diameter deviation | | g5 | g6 | h5 | h6 | j5 | js5 | j6 |
|----------------------------------|-------|---|-----|---------------|---------------|---------------|---------------|---------------|---------------|---------------|
| d mm | | Δd_{mp} | | bearing shaft | bearing shaft | bearing shaft | bearing shaft | bearing shaft | bearing shaft | bearing shaft |
| over | incl. | high | low | | | | | | | |
| 3 | 6 | 0 | -8 | 4T ~ 9L | 4T ~ 12L | 8T ~ 5L | 8T ~ 8L | 11T ~ 2L | 10.5T ~ 2.5L | 14T ~ 2L |
| 6 | 10 | 0 | -8 | 3T ~ 11L | 3T ~ 14L | 8T ~ 6L | 8T ~ 9L | 12T ~ 2L | 11T ~ 3L | 15T ~ 2L |
| 10 | 18 | 0 | -8 | 2T ~ 14L | 2T ~ 17L | 8T ~ 8L | 8T ~ 11L | 13T ~ 3L | 12T ~ 4L | 16T ~ 3L |
| 18 | 30 | 0 | -10 | 3T ~ 16L | 3T ~ 20L | 10T ~ 9L | 10T ~ 13L | 15T ~ 4L | 14.5T ~ 4.5L | 19T ~ 4L |
| 30 | 50 | 0 | -12 | 3T ~ 20L | 3T ~ 25L | 12T ~ 11L | 12T ~ 16L | 18T ~ 5L | 17.5T ~ 5.5L | 23T ~ 5L |
| 50 | 80 | 0 | -15 | 5T ~ 23L | 5T ~ 29L | 15T ~ 13L | 15T ~ 19L | 21T ~ 7L | 21.5T ~ 6.5L | 27T ~ 7L |
| 80 | 120 | 0 | -20 | 8T ~ 27L | 8T ~ 34L | 20T ~ 15L | 20T ~ 22L | 26T ~ 9L | 27.5T ~ 7.5L | 33T ~ 9L |
| 120 | 140 | | | | | | | | | |
| 140 | 160 | 0 | -25 | 11T ~ 32L | 11T ~ 39L | 25T ~ 18L | 25T ~ 25L | 32T ~ 11L | 34T ~ 9L | 39T ~ 11L |
| 160 | 180 | | | | | | | | | |
| 180 | 200 | | | | | | | | | |
| 200 | 225 | 0 | -30 | 15T ~ 35L | 15T ~ 44L | 30T ~ 20L | 30T ~ 29L | 37T ~ 13L | 40T ~ 10L | 46T ~ 13L |
| 225 | 250 | | | | | | | | | |
| 250 | 280 | 0 | -35 | 18T ~ 40L | 18T ~ 49L | 35T ~ 23L | 35T ~ 32L | 42T ~ 16L | 46.5T ~ 11.5L | 51T ~ 16L |
| 280 | 315 | | | | | | | | | |
| 315 | 355 | 0 | -40 | 22T ~ 43L | 22T ~ 54L | 40T ~ 25L | 40T ~ 36L | 47T ~ 18L | 52.5T ~ 12.5L | 58T ~ 18L |
| 355 | 400 | | | | | | | | | |
| 400 | 450 | 0 | -45 | 25T ~ 47L | 25T ~ 60L | 45T ~ 27L | 45T ~ 40L | 52T ~ 20L | 58.5T ~ 13.5L | 65T ~ 20L |
| 450 | 500 | | | | | | | | | |

Table 3.3.2 Fitting against housing

| Nominal outside diameter of bearing | | Single plane mean outside diameter deviation | | G7 | H6 | H7 | J6 | J7 | Js7 | K6 |
|-------------------------------------|-------|--|-----|-----------------|-----------------|-----------------|-----------------|-----------------|-----------------|-----------------|
| d mm | | ΔD_{mp} | | housing bearing | housing bearing | housing bearing | housing bearing | housing bearing | housing bearing | housing bearing |
| over | incl. | high | low | | | | | | | |
| 6 | 10 | 0 | -8 | 5L ~ 28L | 0 ~ 17L | 0 ~ 23L | 4T ~ 13L | 7T ~ 16L | 7.5T ~ 15.5L | 7T ~ 10L |
| 10 | 18 | 0 | -8 | 6L ~ 32L | 0 ~ 19L | 0 ~ 26L | 5T ~ 14L | 8T ~ 18L | 9T ~ 17L | 9T ~ 10L |
| 18 | 30 | 0 | -9 | 7L ~ 37L | 0 ~ 22L | 0 ~ 30L | 5T ~ 17L | 9T ~ 21L | 10.5T ~ 19.5L | 11T ~ 11L |
| 30 | 50 | 0 | -11 | 9L ~ 45L | 0 ~ 27L | 0 ~ 36L | 6T ~ 21L | 11T ~ 25L | 12.5T ~ 23.5L | 13T ~ 14L |
| 50 | 80 | 0 | -13 | 10L ~ 53L | 0 ~ 32L | 0 ~ 43L | 6T ~ 26L | 12T ~ 31L | 15T ~ 28L | 15T ~ 17L |
| 80 | 120 | 0 | -15 | 12L ~ 62L | 0 ~ 37L | 0 ~ 50L | 6T ~ 31L | 13T ~ 37L | 17.5T ~ 32.5L | 18T ~ 19L |
| 120 | 150 | 0 | -18 | 14L ~ 72L | 0 ~ 43L | 0 ~ 58L | 7T ~ 36L | 14T ~ 44L | 20T ~ 38L | 21T ~ 22L |
| 150 | 180 | 0 | -25 | 14L ~ 79L | 0 ~ 50L | 0 ~ 65L | 7T ~ 43L | 14T ~ 51L | 20T ~ 45L | 21T ~ 29L |
| 180 | 250 | 0 | -30 | 15L ~ 91L | 0 ~ 59L | 0 ~ 76L | 7T ~ 52L | 16T ~ 60L | 23T ~ 53L | 24T ~ 35L |
| 250 | 315 | 0 | -35 | 17L ~ 104L | 0 ~ 67L | 0 ~ 87L | 7T ~ 60L | 16T ~ 71L | 26T ~ 61L | 27T ~ 40L |
| 315 | 400 | 0 | -40 | 18L ~ 115L | 0 ~ 76L | 0 ~ 97L | 7T ~ 69L | 18T ~ 79L | 28.5T ~ 68.5L | 29T ~ 47L |
| 400 | 500 | 0 | -45 | 20L ~ 123L | 0 ~ 85L | 0 ~ 108L | 7T ~ 78L | 20T ~ 88L | 31.5T ~ 76.5L | 32T ~ 53L |

Note: T = tight, L = loose

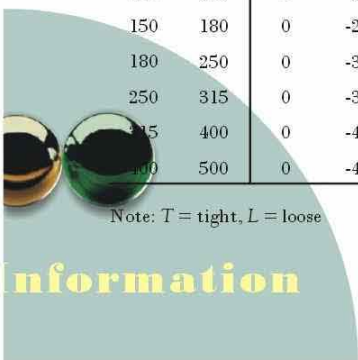

(Unit: μm)

| js6 bearing shaft | k5 bearing shaft | k6 bearing shaft | m5 bearing shaft | m6 bearing shaft | n6 bearing shaft | p6 bearing shaft | r6 bearing shaft | Nominal bore diameter of bearing | |
|----------------------|---------------------|---------------------|---------------------|---------------------|---------------------|---------------------|---------------------|----------------------------------|-----------------|
| | | | | | | | | d mm over | d mm incl |
| 12T ~ 4L | 14T ~ 1T | 17T ~ 1T | 17T ~ 4T | 20T ~ 4T | 24T ~ 8T | 28T ~ 12T | | 3 | 6 |
| 12,5T ~ 4,5L | 15T ~ 1T | 18T ~ 1T | 20T ~ 6T | 23T ~ 6T | 27T ~ 10T | 32T ~ 15T | | 6 | 10 |
| 13,5T ~ 5,5L | 17T ~ 1T | 20T ~ 1T | 23T ~ 7T | 26T ~ 7T | 31T ~ 12T | 37T ~ 18T | | 10 | 18 |
| 16,5T ~ 6,5L | 21T ~ 2T | 25T ~ 2T | 27T ~ 8T | 31T ~ 8T | 38T ~ 15T | 45T ~ 22T | | 18 | 30 |
| 20T ~ 8L | 25T ~ 2T | 30T ~ 2T | 32T ~ 9T | 37T ~ 9T | 45T ~ 17T | 54T ~ 26T | | 30 | 50 |
| 24,5T ~ 9,5L | 30T ~ 2T | 36T ~ 2T | 39T ~ 11T | 45T ~ 11T | 54T ~ 20T | 66T ~ 32T | | 50 | 80 |
| 31T ~ 11L | 38T ~ 3T | 45T ~ 2T | 48T ~ 13T | 55T ~ 13T | 65T ~ 23T | 79T ~ 37T | | 80 | 120 |
| | | | | | | | 113T ~ 63T | 120 | 140 |
| 37,5T ~ 12,5L | 46T ~ 3T | 53T ~ 3T | 58T ~ 15T | 65T ~ 15T | 77T ~ 27T | 93T ~ 43T | 115T ~ 65T | 140 | 160 |
| | | | | | | | 118T ~ 68T | 160 | 180 |
| | | | | | | | 136T ~ 77T | 180 | 200 |
| 44,5T ~ 14,5L | 54T ~ 4T | 63T ~ 4T | 67T ~ 17T | 76T ~ 17T | 90T ~ 31T | 109T ~ 50T | 139T ~ 80T | 200 | 225 |
| | | | | | | | 143T ~ 84T | 225 | 250 |
| | | | | | | | 161T ~ 94T | 250 | 280 |
| 51T ~ 16L | 62T ~ 4T | 71T ~ 4T | 78T ~ 20T | 87T ~ 20T | 101T ~ 34T | 123T ~ 56T | 165T ~ 98T | 280 | 315 |
| | | | | | | | 184T ~ 108T | 315 | 355 |
| 58T ~ 18L | 69T ~ 4T | 80T ~ 4T | 86T ~ 21T | 97T ~ 21T | 113T ~ 37T | 138T ~ 62T | 190T ~ 114T | 355 | 400 |
| | | | | | | | 211T ~ 126T | 400 | 450 |
| 65T ~ 20L | 77T ~ 5T | 90T ~ 4T | 95T ~ 23T | 108T ~ 23T | 125T ~ 40T | 153T ~ 68T | 217T ~ 132T | 450 | 500 |

(Unit: μm)

| K7 housing bearing | M7 housing bearing | N7 housing bearing | P7 housing bearing | Nominal outside diameter of bearing | |
|-----------------------|-----------------------|-----------------------|-----------------------|-------------------------------------|-----------------|
| | | | | d mm over | d mm incl |
| 10T ~ 13L | 15T ~ 8L | 19T ~ 4L | 24T ~ 1L | 6 | 10 |
| 12T ~ 14L | 18T ~ 8L | 23T ~ 3L | 29T ~ 3L | 10 | 18 |
| 15T ~ 15L | 21T ~ 9L | 28T ~ 2L | 35T ~ 5L | 18 | 30 |
| 18T ~ 18L | 25T ~ 11L | 33T ~ 3L | 42T ~ 6L | 30 | 50 |
| 21T ~ 22L | 30T ~ 13L | 39T ~ 4L | 52T ~ 8L | 50 | 80 |
| 25T ~ 25L | 35T ~ 15L | 45T ~ 5L | 59T ~ 9L | 80 | 120 |
| 28T ~ 30L | 40T ~ 18L | 52T ~ 6L | 68T ~ 10L | 120 | 150 |
| 28T ~ 37L | 40T ~ 25L | 52T ~ 13L | 68T ~ 3L | 150 | 180 |
| 33T ~ 43L | 46T ~ 30L | 60T ~ 16L | 79T ~ 3L | 180 | 250 |
| 36T ~ 51L | 52T ~ 35L | 66T ~ 21L | 88T ~ 1L | 250 | 315 |
| 40T ~ 57L | 57T ~ 40L | 73T ~ 24L | 98T ~ 1L | 315 | 400 |
| 45T ~ 63L | 63T ~ 45L | 80T ~ 28L | 108T ~ 0 | 400 | 500 |



4. Bearing internal clearance

Table 4.1 Radial internal clearance of needle roller bearings

(Unit: μm)

| Nominal bore diameter d (mm) | | C2 | | Normal | | C3 | | C4 | |
|-----------------------------------|-------|------|------|--------|------|------|------|------|------|
| over | incl. | min. | max. | min. | max. | min. | max. | min. | max. |
| - | 10 | 0 | 30 | 10 | 40 | 25 | 55 | 35 | 65 |
| 10 | 18 | 0 | 30 | 10 | 40 | 25 | 55 | 35 | 65 |
| 18 | 24 | 0 | 30 | 10 | 40 | 25 | 55 | 35 | 65 |
| 24 | 30 | 0 | 30 | 10 | 45 | 30 | 65 | 40 | 70 |
| 30 | 40 | 0 | 35 | 15 | 50 | 35 | 70 | 45 | 80 |
| 40 | 50 | 5 | 40 | 20 | 55 | 40 | 75 | 55 | 90 |
| 50 | 65 | 5 | 45 | 20 | 65 | 45 | 90 | 65 | 105 |
| 65 | 80 | 5 | 55 | 25 | 75 | 55 | 105 | 75 | 125 |
| 80 | 100 | 10 | 60 | 30 | 80 | 65 | 115 | 90 | 140 |
| 100 | 120 | 10 | 65 | 35 | 90 | 80 | 135 | 105 | 160 |
| 120 | 140 | 10 | 75 | 40 | 105 | 90 | 155 | 115 | 180 |
| 140 | 160 | 15 | 80 | 50 | 115 | 100 | 165 | 130 | 195 |
| 160 | 180 | 20 | 85 | 60 | 125 | 110 | 175 | 150 | 215 |
| 180 | 200 | 25 | 95 | 65 | 135 | 125 | 195 | 165 | 235 |
| 200 | 225 | 30 | 105 | 75 | 150 | 140 | 215 | 180 | 255 |
| 225 | 250 | 40 | 115 | 90 | 165 | 155 | 230 | 205 | 280 |
| 250 | 280 | 45 | 125 | 100 | 180 | 175 | 255 | 230 | 310 |
| 280 | 315 | 50 | 135 | 110 | 195 | 195 | 280 | 255 | 340 |
| 315 | 355 | 55 | 145 | 125 | 215 | 215 | 305 | 280 | 370 |
| 355 | 400 | 65 | 160 | 140 | 235 | 245 | 340 | 320 | 415 |
| 400 | 450 | 70 | 190 | 155 | 275 | 270 | 390 | 355 | 465 |

5. Lubrication

5.1 Lubrication of rolling bearings

The purpose of bearing lubrication is to prevent direct metallic contact between the various rolling and sliding elements. This is accomplished through the formation of a thin oil (or grease) film on the contact surfaces. However, for rolling bearings, lubrication has the following advantages:

- (1) Friction and wear reduction
- (2) Friction heat dissipation
- (3) Prolonged bearing life
- (4) Prevention of rust
- (5) Protection against harmful elements

In order to achieve the above effects, the most effective lubrication method for the operating conditions must be selected. Also, a good quality, reliable lubricant must be selected. In addition, an effectively designed sealing system that prevents the intrusion of damaging elements (Dust, water, etc.) into the bearing interior, removes dust and other impurities from the lubricant, and prevents the lubricant from leaking to the outside, is also a requirement. Almost all rolling bearings use either grease or oil lubrication methods, but in some special applications, a solid lubricant such as molybdenum disulfide or graphite may be used.



5.2 Lubrication methods and characteristics

The lubrication methods come in two general methods: grease or oil, each with their own characteristics. These characteristics are shown in table 5.1

Table 5.1 Comparison of grease lubrication and oil lubrication characteristics

| Concern | Method | Grease lubrication | Oil lubrication |
|---------------------------|--------|--------------------|------------------------------|
| Handling | | Very good | Fair |
| Reliability | | Good | Very good |
| Cooling effect | | Poor | Good (circulation necessary) |
| Seal's structure | | Good | Fair |
| Power loss | | Good | Good |
| Environment contamination | | Good | Fair |
| High speed rotation | | Poor | Good |

5.3 Grease lubrication

Grease type lubricants are relatively easy to handle and require only the simplest sealing devices. For these reasons, grease is the most widely used lubricant for rolling bearings.

5.3.1 Types and characteristics of grease

Lubricating greases are composed of either a mineral oil base or a synthetic oil base. To this base a thickener and other additives are added. The properties of all greases are mainly determined by the kind of base oil used and by the combination of thickening agent and various additives.

Standard greases and their characteristics are listed in Table 5.2 as performance characteristics of even the same type of grease will vary widely from brand to brand, it is best to check the manufacturers' data when selecting a grease.

Also, greases of different brands should not be mixed because of the different additives they contain.

However, if different greases must be mixed, at least greases with the same base oil and thickening agent should be selected. But even when greases of the same base oil and thickening agent are mixed, the quality of the grease may still change due to the difference in additives. For this reason, changes in consistency and other qualities should be checked before being applied.

Table 5.2 Grease varieties and characteristics

| Grease name | Lithium grease | | | Sodium grease (Fiber grease) | Calcium compound base grease |
|--------------------------------|---|---|--|--|---|
| Thickener | Li soap | | | Na soap | Ca+Na soap Ca+Li soap |
| Base oil | Mineral oil | Diester oil | Silicone oil | Mineral oil | Mineral oil |
| Dropping point | 170 °C ~ 190 °C | 170 °C ~ 190 °C | 200 °C ~ 250 °C | 150 °C ~ 180 °C | 150 °C ~ 180 °C |
| Operating temperature range °C | -30 °C ~ +130 °C | -50 °C ~ +130 °C | -50 °C ~ +160 °C | -20 °C ~ +130 °C | -20 °C ~ +120 °C |
| Mechanical stability | Excellent | Good | Good | Excellent ~ Good | Excellent ~ Good |
| Pressure resistance | Good | Good | Poor | Good | Excellent ~ Good |
| Water resistance | Good | Good | Good | Good ~ Poor | Good ~ Poor |
| Applications | Widest range of applications. | Excellent low temperature and wear characteristics. | Suitable for high and low temperature. | Some emulsification when water is introduced. | Excellent pressure resistance and mechanical stability. |
| | Grease used in all types of rolling bearings. | Suitable for small sized and miniature bearings. | Unsuitable for heavy load applications due to low oil film strength. | Excellent characteristics at relatively high temperatures. | Suitable for bearings receiving shock loads. |

| Grease name | Aluminum grease | Non-soap base grease Thickener | |
|--------------------------------|--|--|------------------|
| Thickener | Al soap | Bentone, silica gel, urea, carbon black, fluorine compounds, etc. | |
| Base oil | Mineral oil | Mineral oil | Synthetic oil |
| Dropping point | 70 °C ~ 90 °C | 250 °C or above | 250 °C or above |
| Operating temperature range °C | -10 °C ~ +80 °C | -10 °C ~ +130 °C | -50 °C ~ +200 °C |
| Mechanical stability | Good ~ Poor | Good | Good |
| Pressure resistance | Good | Good | Good |
| Water resistance | Good | Good | Good |
| Applications | Excellent viscosity characteristics. | Can be used in a wide range of low to high temperatures. Shows excellent heat resistance, cold resistance, chemical resistance, and other characteristics when matched with a suitable base oil and thickener. | |
| | Suitable for bearings subject to vibrations. | Grease used in all types of rolling bearings. | |

Note: The figures given for operating temperature range are standard characteristic values, and are not guaranteed.

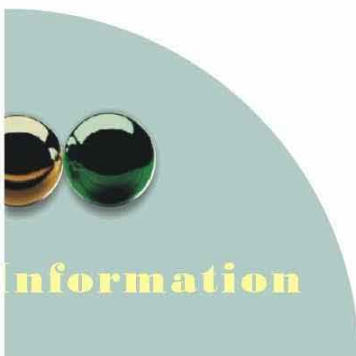

5.3.2 Amount of grease

The amount of grease used in any given situation will depend on many factors relating to the size and shaped the housing, space limitations, bearing's rotating speed and type of grease used.

As a general rule, housings and bearings should be only filled from 50% to 80% of their capacities.

Where speeds are high and temperature rises need to be kept to a minimum, a reduced amount of grease should be used. Excessive amounts of grease cause temperature rise which in turn causes the grease to soften and may allow leakage. With excessive grease fills oxidation and deterioration may cause lubricating efficiency to be lowered.

Moreover, the standard bearing space can be found by below formula (5.1)

$$V = K \cdot W \text{ Formula (5.1)}$$

where,

V : Quantity of bearing space open type (approx.) Cm³

K : Bearing space factor (Table 5.3)

W : Mass of bearing kg (See bearing tables)

Table 5.3 Bearings space ratio K

| Bearing type | Retainer type | K |
|------------------------|---------------------------------|----|
| Needle roller bearings | Pressed or Machined retainer | 35 |



6. Load rating and life

6.1 Bearing life

Even in bearings operating under normal conditions, the surfaces of the raceway and rolling elements are constantly being subjected to repeated compressive stresses which causes flaking of these surfaces to occur. This flaking is due to material fatigue and will eventually cause the bearings to fail. The effective life of a bearing is usually defined in terms of the total number of revolutions a bearing can undergo before flaking of either the raceway surface or the rolling element surfaces occurs.

Other causes of bearing failure are often attributed to problems such as seizing, abrasions, cracking, chipping, gnawing, rust, etc. However, these so called "causes" of bearing failure are usually themselves caused by improper installation, insufficient or improper lubrication, faulty sealing or inaccurate bearing selection. Since the above mentioned "causes" of bearing failure can be avoided by taking the proper precautions, and are not simply caused by material fatigue, they are considered separately from the flaking aspect.

6.2 Basic rated life and basic dynamic load rating

A group of seemingly identical bearings when subjected to identical load and operating conditions will exhibit a wide diversity in their durability. This "life" disparity can be accounted for by the difference in the fatigue of the bearing material itself. This disparity is considered statistically when calculating bearing life, and the basic rated life is defined as follows.

The basic rated life is based on a 90% statistical model which is expressed as the total number of revolutions 90% of the bearings in an identical group of bearings subjected to identical operating conditions will attain or surpass before flaking due to material fatigue occurs. For bearings operating at fixed constant speeds, the basic rated life (90% reliability) is expressed in the total number of hours of operation.

The basic dynamic load rating is an expression of the load capacity of a bearing based on a constant load which the bearing can sustain for one million revolutions (the basic life rating). For radial bearings this rating applies to pure radial loads, and for thrust bearings it refers to pure axial loads. The basic dynamic load ratings given in the bearing tables of this catalogue are for bearings constructed of **KSM** standard bearing materials, using standard manufacturing techniques. Please consult **KSM** Engineering for basic load ratings of bearings constructed of special materials or using special manufacturing techniques.

The relationship between the basic rated life, the basic dynamic load rating and the bearing load is given in formula (6.1).

$$L_{10} = \left(\frac{C}{P}\right)^P \dots \dots \dots \text{Formula (6.1)}$$

where,

$P = 10/3$ For needle roller bearings

L_{10} : Basic rating life 10^6 revolutions

C : Basic dynamic rating load, N
 (C_r : radial bearings, C_a : thrust bearings)

P : Equivalent dynamic load, N
 (P_r : radial bearings, P_a : thrust bearings)

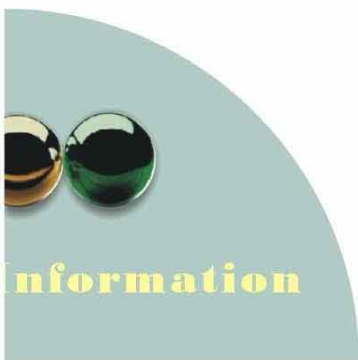

The basic rating life can also be expressed in terms of hours of operation (revolution), and is calculated as shown in formula (6.2).

$$L_{10h} = 500 f_h^p \dots\dots\dots \text{Formula (6.2)}$$

$$f_h = f_n \frac{C}{P} \dots\dots\dots \text{Formula (6.3)}$$

$$f_n = \left(\frac{33.3}{n} \right)^{1/p} \dots\dots\dots \text{Formula (6.4)}$$

where,

L_{10} : Basic rating life, h

f_h : Life factor

f_n : Speed factor

n : Rotational speed, r/min

Formula (6.2) can also be expressed as shown in formula (6.5).

$$L_{10h} = \frac{10^6}{60n} \left(\frac{C}{P} \right)^p \dots\dots\dots \text{Formula (6.5)}$$

The relationship between Rotational speed n and speed factor f_n as well as the relation between the basic rating life L_{10h} and the life factor f_h is shown in Fig. 6.1. When several bearings are incorporated in machines or equipment as complete units, all the bearings in the unit are considered as a whole when computing bearing life (see formula 6.6). The total bearing life of the unit is a life rating based on the viable lifetime of the unit before even one of the bearings fails due to rolling contact fatigue.

$$L = \frac{1}{\left(\frac{1}{L_1^e} + \frac{1}{L_2^e} + \dots + \frac{1}{L_n^e} \right)^{1/e}} \dots\dots\dots \text{Formula (6.6)}$$

where,

$e = 9/8$For roller bearings

L = Total basic rating life or entire unit, h

L_1, L_2, \dots, L_n : Basic rating life or individual bearings, 1, 2, ..., n , h

6.3 Machine applications and requisite life

When selecting a bearing, it is essential that the requisite life of the bearing be established in relation to the operating conditions. The requisite life of the bearing is usually determined by the type of machine in which the bearing will be used, and duration of service and operational reliability requirements. A general guide to these requisite life criteria is shown in Table 6.1. When determining bearing size, the fatigue life of the bearing is an important factor; however, besides bearing life, the strength and rigidity of the shaft and housing must also be taken into consideration.

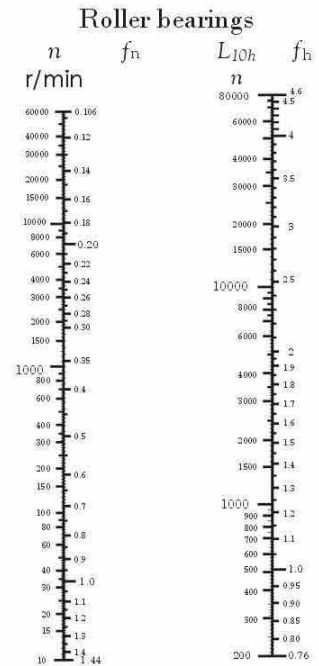

Fig. 6.1 Bearing life rating scale

6.4 Adjusted life rating factor

The basic bearing life rating (90% reliability factor) can be calculated through the formula mentioned earlier in Section 6.2. However, in some applications a bearing life factor of over 90% reliability may be required. To meet these requirements, bearing life can be lengthened by the use of specially improved bearing materials or special construction techniques. Moreover, according to elastohydrodynamic lubrication theory, it is clear that the bearing operating conditions (lubrication, temperature, speed, etc.) all exert an effect on bearing life.

$$L_{na} = a_1 \cdot a_2 \cdot a_3 (C/P)^P \dots \dots \dots \text{Formula (6.7)}$$

where,

L_{na} : Adjusted life rating in millions of revolutions (10^6) (adjusted for reliability, material and operating conditions)

a_1 : Reliability adjustment factor

a_2 : Material adjustment factor

a_3 : Operating condition adjustment factor

6.4.1 Life adjustment factor for reliability a_1

The values for the reliability adjustment factor a_1 (for a reliability factor higher than 90%) can be found in Table 6.1.

Table 6.1 Reliability adjustment factor values a_1

| Reliability % | L_n | Reliability factor a_1 |
|---------------|-------|--------------------------|
| 90 | L10 | 1.00 |
| 95 | L5 | 0.62 |
| 96 | L4 | 0.53 |
| 97 | L3 | 0.44 |
| 98 | L2 | 0.33 |
| 99 | L1 | 0.21 |

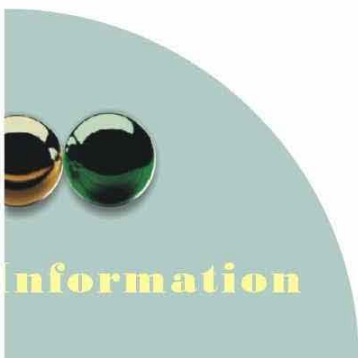

6.4.2 Life adjustment factor for material a_2

The life of a bearing is affected by the material type and quality as well as the manufacturing process. In this regard, the life is adjusted by the use of an a_2 factor.

The basic dynamic load ratings listed in the catalog are based on KSM's standard material and process, therefore, the adjustment factor $a_2 = 1$. When special materials or processes are used the adjustment factor can be larger than 1.

KSM Bearings can generally be used up to 120 °C. If bearings are operated at a higher temperature, the bearing must be specially heat treated (stabilized) so that inadmissible dimensional change does not occur due to changes in the micro-structure. This special heat treatment might cause the reduction of bearing life because of a hardness change.

6.4.3 Life adjustment factor a_3 for operating conditions

The operating conditions life adjustment factor a_3 is used to adjust for such conditions as lubrication, operating temperature, and other operation factors which have an effect on bearing life.

Generally speaking, when lubricating conditions are satisfactory, the a_3 factor has a value of one; and when lubricating conditions are exceptionally favorable, and all other operating conditions are normal, a_3 can have a value greater than one.

However, when lubricating conditions are particularly unfavorable and the oil film formation on the contact surfaces of the raceway and rolling elements is insufficient, the value of a_3 becomes less than one. This insufficient oil film formation can be caused, for example, by the lubricating oil viscosity being too low for the operating temperature (below 13 mm²/s for ball bearings; below 20mm²/s for roller bearings); or by exceptionally low rotational speed (nr/min x d_b mm less than 10,000). For bearings used under special operating conditions, please consult KSM Engineering.

As the operating temperature of the bearing increases, the hardness of the bearing material decreases. Thus, the bearing life correspondingly decreases. The operating temperature adjustment values are shown in Fig. 6.2.

6.5 Life of bearing with oscillating motion

The life of a radial bearing with oscillating motion can be calculated according to formula (6.8).

$$L_{osc} = \Omega L_{Rot} \dots\dots\dots \text{Formula (6.8)}$$

where,

L_{osc} : life for oscillating bearing

L_{Rot} : rating life at assumed number of rotations same as oscillation cycles

Ω : oscillation factor (Fig.6.3 indicates the relationship between half oscillation angle β and Ω).

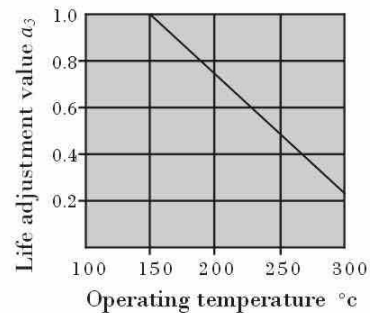

Fig. 6.2 Life adjustment value for operating temperature

If the cycle and travel distance within a particular travel motion remain constant, the rating life of the bearing can be determined by formulas (6.10) .

$$Lh = \frac{50 \times 10^3}{10 \cdot S} \left(\frac{C_r}{P_r} \right)^{\frac{10}{3}} \dots \dots \dots \text{Formula (6.10)}$$

Where,

Lh : Travel life, h

S : Travel distance per minute, m/min.

$$S = 2 \cdot L \cdot N$$

L : Stroke length, m

n : Stroke cycle, N {kgf}

6.7 Basic static load rating

When stationary rolling bearings are subjected to static loads, they suffer from partial permanent deformation of the contact surfaces at the contact point between the rolling elements and the raceway. The amount of deformity increases as the load increases, and if this increase in load exceeds certain limits, the subsequent smooth operation of the bearings is impaired.

It has been found through experience that a permanent deformity of 0.0001 times the diameter of the rolling element, occurring at the most heavily stressed contact point between the raceway and the rolling elements, can be tolerated without any impairment in running efficiency.

The basic rated static load refers to a fixed static load limit at which a specified amount of permanent deformation occurs. It applies to pure radial loads for radial bearings and to pure axial loads for thrust bearings. The maximum applied load values for contact stress occurring at the rolling element and raceway contact points are given below.

For roller bearings 4,000 Mpa

6.8 Allowable static equivalent load

Generally the static equivalent load which can be permitted is limited by the basic static rated load as stated in Section 6.7. However, depending on requirements regarding friction and smooth operation, these limits may be greater or lesser than the basic static rated load.

In the following formula (6.11) and Table 6.4 the safety factor S_o can be determined considering the maximum static equivalent load.

$$S_o = C_o / P_o \dots \dots \dots \text{Formula (6.11)}$$

where,

S_o : Safety factor

C_o : Basic static rated load, N
 (radial bearings: C_{or} , thrust bearings: C_{oa})

$P_o \text{ max}$: Maximum static equivalent load, N
 (radial: $P_{or \text{ max}}$, thrust: $C_{oa \text{ max}}$)

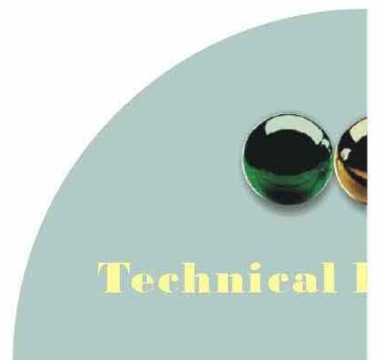

Table 6.3 Minimum safety factor values S_o

| Operating conditions | Roller bearings |
|---|-----------------|
| High rotational accuracy demand | 3.0 |
| Normal rotating accuracy demand (Universal application) | 1.5 |
| Slight rotational accuracy deterioration permitted (Low speed, heavy loading, etc.) | 1.0 |

Note 1 : For drawn-cup needle roller bearings, min. S_o value=3.

2 : When vibration and/or shock loads are present, a load factor based on the shock load needs to be included in the P_o max value.

7. Bearing handling

Bearings are precision parts and, in order to preserve their accuracy and reliability, care must be exercised in their handling. In particular, bearing cleanliness must be maintained, sharp impacts avoided, and rust prevented.

7.1 Bearing storage

Most rolling bearings are coated with a rust preventative before being packed and shipped, and they should be stored at room temperature with a relative humidity of less than 60%.

7.2 Installation

When bearings are being installed on shafts or in housings, the bearing rings should never be struck directly with a hammer or a drift, as shown in Fig. 7.1, because damage to the bearing may result. Any force applied to the bearing should always be evenly distributed over the entire bearing ring face.

7.2.1 Installation preparations

Bearings should be fitted in a clean, dry work area. Specially for small and miniature bearings, a "clean room" should be provided as any contamination particles in the bearing will greatly affect bearing efficiency. Before installation, all fitting tools, shafts, housings, and related parts should be cleaned and any burrs or cutting chips removed if necessary. Shaft and housing fitting surfaces should also be checked for roughness, dimensional and design accuracy, and to ensure that they are within allowable tolerance limits. Bearings should not be unwrapped until just prior to installation. Normally, bearings to be used with grease lubricant can be installed as is, without removing the rust preventative. However, for bearings which will use oil lubricant, or in cases where mixing the grease and rust preventative would result in loss of lubrication efficiency, the rust preventative should be removed by washing with benzene or petroleum solvent and dried before installation. Bearings should also be washed and dried before installation if the package has been damaged or there are other chances that the bearings have been contaminated. Double shielded bearings and sealed bearings, one way clutches should never be washed.

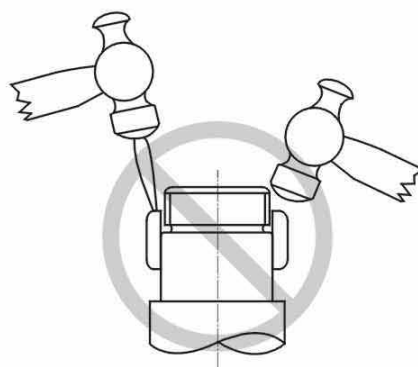

Fig. 7.1



7.2.2 Installing cylindrical bore bearings

Bearings with relatively small interference fits can be press fit at room temperature by using a sleeve against the inner ring face as shown in Fig. 7.2. Usually, bearings are installed by striking the sleeve with a hammer; however, when installing a large number of bearings, a mechanical or hydraulic press should be used.

When installing non-separable bearings on a shaft and in a housing simultaneously, a pad which distributes the fitting pressure evenly over the inner and outer rings is used as shown in Fig. 7.3. When fitting bearings which have a large inner ring interference fit, or when fitting bearings on shafts that have a large diameter, a considerable amount of force is required to install the bearing at room temperature. Installation can be facilitated by heating and expanding the inner ring beforehand. The required relative temperature difference between the inner ring and the fitting surface depends on the amount of interference and the shaft fitting surface diameter. Fig. 7.4 shows the relation between the bearing inner bore diameter temperature differential and the amount of thermal expansion. In any event, bearing-s should never be heated above 120 °C.

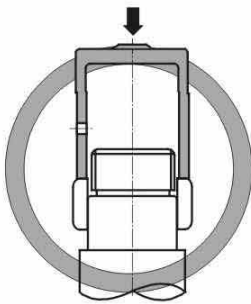

Fig. 7.2 Fitting sleeve pressure against inner ring

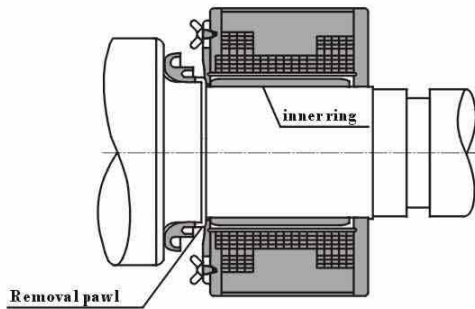

Fig. 7.4 Removal of inner ring using an induction heater

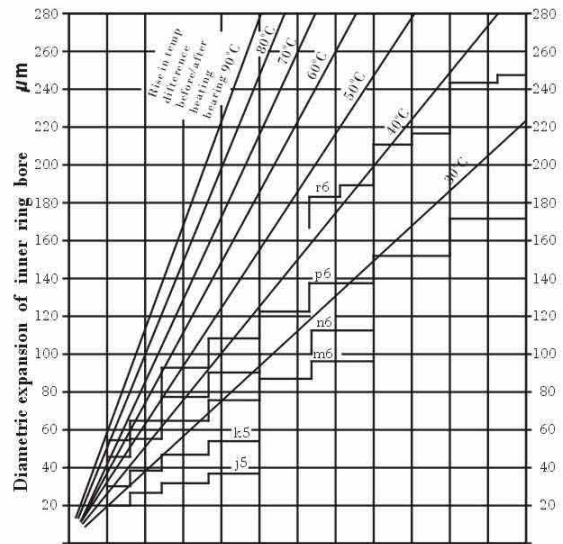

Fig. 7.3 Temperature differential required for shrinkage fit of inner ring



The most commonly used method of heating bearings is to immerse them in hot oil. However, this method should not be used for pre lubricated shielded and sealed bearings. To avoid overheating parts of the bearings they should never be brought into direct contact with the heat source, but instead should be suspended inside the heating tank or placed on a wire grid. If bearings are dry-heated with a heating cabinet or hot plate, they can be mounted without drying. An induction heater can be used to quickly heat bearings in a dry state (always demagnetize). When heated bearings are installed on shafts, the inner rings must be held against the shaft abutment until the bearing has been cooled in order to prevent gaps from occurring between the ring and the abutment face.

7.2.3 Installation of outer ring

Even for tight interference fits, the outer rings of small type bearings can be installed by driving them into housings at room temperature. For large type bearings, the housing can be heated before installing the bearing, or the bearing's outer ring can be cooled with dry ice, etc. Before installing. If dry ice or other cooling agent is used, atmospheric moisture will condense on bearing surfaces, and therefore appropriate rust preventative measures are necessary.

7.3 Post installation running test

To insure that the bearing has been properly installed, a running test is performed after installation is completed. The shaft or housing is first rotated by hand and if no problems are observed a low speed, no load power test is performed. If no abnormalities are observed, the load and speed are gradually increased to operating conditions. During the test if any unusual noise, vibration, or temperature rise is observed the test should be stopped and the equipment examined. If necessary, the bearing should be disassembled for inspection. To check bearing running noise, the sound can be amplified and the type of noise ascertained with a listening instrument placed against the housing. A clear, smooth and continuous running sound is normal. A high, metallic or irregular sound indicates some error in function. Vibration can be accurately checked with a vibration measuring instrument, and the amplitude and frequency characteristics measured against a fixed standard. Usually the bearing temperature can be estimated from the housing surface temperature. However, if the bearing outer ring is accessible through oil inlets, etc., the temperature can be more accurately measured. Under normal conditions, bearing temperature rises with rotation time and then reaches a stable operating temperature after a certain period of time. If the temperature does not level off and continues to rise, or if there is a sudden temperature rise, or if the temperature is unusually high, the bearing should be inspected.

7.4 Bearing disassembly

Bearings are often removed as part of periodic inspection procedures or during the replacement of other parts. However, the shaft and housing are almost always reinstalled, and in more than a few cases the bearings themselves are reused. These bearings, shafts, housings, and other related parts must be designed to prevent damage during disassembly procedures, and the proper disassembly tools must be employed. When removing inner and outer rings which have been installed with interference fits, the dismounting force should be applied to that ring only and not applied to other parts of the bearing, as this may cause internal damage to the bearing's raceway or rolling elements.

7.4.1 Disassembly of bearings with cylindrical bores

For small type bearings, the pullers shown in Fig. 7.5 or the press method shown in Fig. 7.6 can be used for disassembly. When used properly, these methods can improve disassembly efficiency and prevent damage to bearings. To facilitate disassembly procedures, attention should be given to planning the designs of shafts and housings, such as providing extraction grooves on the shaft and housing for puller claws as shown Figs. 7.7 and 7.8. Threaded bolt holes should also be provided in housings to facilitate the pressing out of outer rings as shown in Fig. 7.9.

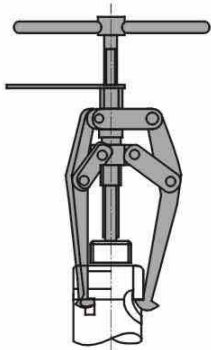

Fig. 7.5 Puller disassembly

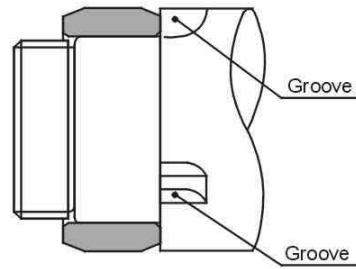

Fig. 7.7 Extracting grooves

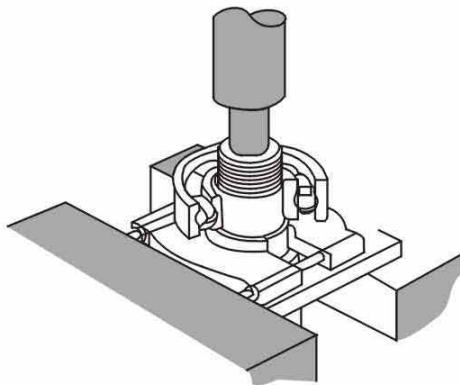

Fig. 7.6 press disassembly

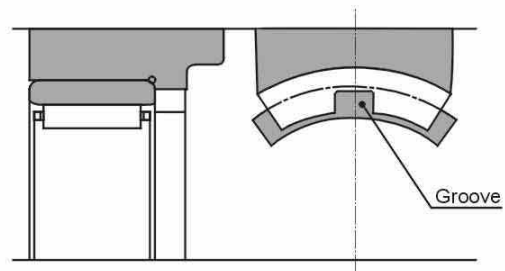

Fig. 7.8 Extraction groove for outer ring disassembly

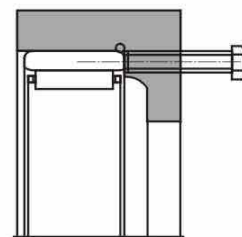
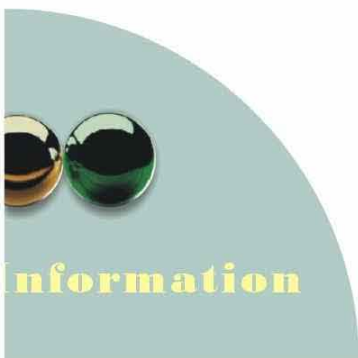

Fig. 7.9 Outer ring disassembly bolt





Needle roller and cage assemblies



TECHNICAL SUPPLEMENT

T034

PRODUCT INFORMATION

P035 - 042



K

P035 - 042

1. Types and designs

KSM Needle Roller and Cage Assemblies are supplied in single row Fig. 1. The single row cages are available in two configurations: machined ring (series K), and molded polyamide reinforced with glass or carbon fiber (series K - TV). The T2 cage features a maximum allowable operating temperature of 120° C and maximum allowable continuous operating temperature of 100° C .



Fig.1

2. Bearing numbers

As summarized in Fig. 2, the bearing numbers of KSM Needle Roller and Cage Assemblies comprise a series number , a dimension code (inscribed enveloping circle diameter × roller set outside diameter×cage width), and a suffix.

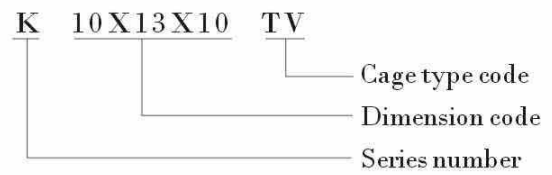

Fig. 2

3. Radial clearance

When the shaft and housing are used as the raceway, the radial clearance of the ball and age assembly is governed by the shaft diameter and housing bore dimension. Usually, if the tolerance range of the needle rollers is one of the standard groups, the shaft diameter and housing bore diameter in Table 1 are used.

Table 1 Recommended fits

| Shaft dia. mm | | ≥80 | 81~139 | 140≥ |
|------------------|-------------------------------|-------|--------|-------|
| Radial clearance | Smaller than normal clearance | j5/G6 | H5/G6 | h5/G6 |
| | Normal clearance | h5/G6 | g5/G6 | f5/H6 |
| | Greater than normal clearance | g6/G6 | f6/G6 | f6/G6 |

4. Shaft and housing requirements

When used as a raceway, a shaft and housing must satisfy the requirements indicated in Table 2.

Table 2 Shaft and housing requirements

| Characteristics | Shaft | Housing |
|--------------------------|----------|---------|
| Circularity (max.) | IT3 | IT4 |
| Cylindricity (max.) | IT3 | IT4 |
| Surface roughness (max.) | 0.4a | 0.4a |
| Surface roughness (max.) | HRC58~64 | |

5. Mounting dimensions for bearings

Table 3 gives the recommended tolerance for the cage guide width *b* dimension relative to the nominal dimension " *B_c* ".

Table 3 Tolerance for guide width

| Series classification | Tolerance for <i>b</i> |
|-----------------------|---|
| Metric | $B_c \begin{matrix} +0.2 \\ 0 \end{matrix}$ |

Cage and roller type needle roller bearings series K

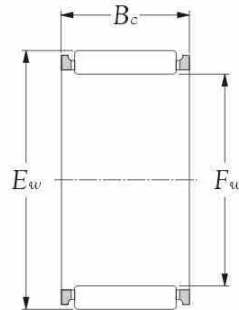

| Inner bore F_w mm | Bearing number | Principal dimensions | | Basic load ratings | | | | Max runout speed | | Weight kg. |
|---------------------------|----------------|----------------------|-------------------------------------|--------------------|----------------------|---------------------|------------------------|------------------|--------------|---------------|
| | | E_w mm | B_c mm | Dynamic C N | static C_o N | Dynamic C kgf | static C_o kgf | grease r/min | oil r/min | |
| 3 | K 3x6x7 | 6 | 7 ^{-0.2} _{-0.55} | 1460 | 970 | 149 | 99 | 33000 | 50000 | 0.0004 |
| 4 | K 4x7x7 | 7 | 7 ^{-0.2} _{-0.55} | 1770 | 1270 | 180 | 129 | 30000 | 45000 | 0.0005 |
| 5 | K 5x8x8 | 8 | 8 ^{-0.2} _{-0.55} | 2640 | 2190 | 269 | 224 | 27000 | 40000 | 0.0007 |
| 5 | K 5x8x10 | 8 | 10 ^{-0.2} _{-0.55} | 2720 | 2250 | 277 | 230 | 27000 | 40000 | 0.0009 |
| 6 | K 6x9x8 | 9 | 8 ^{-0.2} _{-0.55} | 2660 | 2280 | 272 | 233 | 25000 | 37000 | 0.0009 |
| 6 | K 6x9x10 | 9 | 10 ^{-0.2} _{-0.55} | 3400 | 3150 | 345 | 320 | 25000 | 37000 | 0.0011 |
| 6 | K 6x10x13 | 10 | 13 ^{-0.2} _{-0.55} | 4400 | 3700 | 450 | 380 | 25000 | 37000 | 0.0019 |
| 7 | K 7x10x8 | 10 | 8 ^{-0.2} _{-0.55} | 2670 | 2350 | 272 | 239 | 23000 | 34000 | 0.0009 |
| 7 | K 7x10x10 | 10 | 10 ^{-0.2} _{-0.55} | 3400 | 3200 | 345 | 330 | 23000 | 34000 | 0.0011 |
| 8 | K 8x11x8 | 11 | 8 ^{-0.2} _{-0.55} | 3150 | 3000 | 320 | 305 | 21000 | 32000 | 0.0011 |
| 8 | K 8x11x10 | 11 | 10 ^{-0.2} _{-0.55} | 4000 | 4100 | 410 | 420 | 21000 | 32000 | 0.0013 |
| 8 | K 8x11x13 | 11 | 13 ^{-0.2} _{-0.55} | 4850 | 5200 | 495 | 535 | 21000 | 32000 | 0.0026 |
| 8 | K 8x12x10 | 12 | 10 ^{-0.2} _{-0.55} | 4650 | 4150 | 475 | 425 | 21000 | 32000 | 0.0020 |
| 8 | K 8x12x12 | 12 | 12 ^{-0.2} _{-0.55} | 5600 | 5300 | 570 | 540 | 21000 | 32000 | 0.0034 |
| 8 | K 8x12x13 | 12 | 13 ^{-0.2} _{-0.55} | 5600 | 5300 | 570 | 540 | 21000 | 32000 | 0.0036 |
| 9 | K 9x12x10 | 12 | 10 ^{-0.2} _{-0.55} | 4550 | 5000 | 465 | 510 | 20000 | 30000 | 0.0015 |
| 9 | K 9x12x13 | 12 | 13 ^{-0.2} _{-0.55} | 5500 | 6400 | 560 | 650 | 20000 | 30000 | 0.0021 |
| 10 | K 10x13x10 | 13 | 10 ^{-0.2} _{-0.55} | 4550 | 5100 | 460 | 520 | 19000 | 28000 | 0.0016 |
| 10 | K 10x13x13 | 13 | 13 ^{-0.2} _{-0.55} | 5450 | 6450 | 555 | 660 | 19000 | 28000 | 0.0031 |
| 10 | K 10x14x8 | 14 | 8 ^{-0.2} _{-0.55} | 4300 | 3950 | 435 | 405 | 19000 | 28000 | 0.0027 |
| 10 | K 10x14x10 | 14 | 10 ^{-0.2} _{-0.55} | 5500 | 5450 | 560 | 555 | 19000 | 28000 | 0.0034 |
| 10 | K 10x14x13 | 14 | 13 ^{-0.2} _{-0.55} | 6600 | 6900 | 675 | 705 | 19000 | 28000 | 0.0044 |
| 10 | K 10x16x12 | 16 | 12 ^{-0.2} _{-0.55} | 7100 | 5950 | 720 | 610 | 19000 | 28000 | 0.0066 |
| 11 | K 11x14x10 | 14 | 10 ^{-0.2} _{-0.55} | 5050 | 6000 | 515 | 615 | 18000 | 27000 | 0.0028 |
| 12 | K 12x15x9 | 15 | 9 ^{-0.2} _{-0.55} | 4450 | 5250 | 455 | 535 | 17000 | 26000 | 0.0027 |
| 12 | K 12x15x13 | 15 | 13 ^{-0.2} _{-0.55} | 6000 | 7700 | 615 | 785 | 17000 | 26000 | 0.0038 |
| 12 | K 12x16x8 | 16 | 8 ^{-0.2} _{-0.55} | 4850 | 4900 | 495 | 500 | 17000 | 26000 | 0.0034 |
| 12 | K 12x16x13 | 16 | 13 ^{-0.2} _{-0.55} | 7500 | 8500 | 765 | 870 | 17000 | 26000 | 0.0055 |
| 12 | K 12x17x13 | 17 | 13 ^{-0.2} _{-0.55} | 9000 | 9400 | 920 | 960 | 17000 | 26000 | 0.0075 |
| 12 | K 12x18x12 | 18 | 12 ^{-0.2} _{-0.55} | 8650 | 8000 | 880 | 815 | 17000 | 26000 | 0.0084 |
| 14 | K 14x17x10 | 17 | 10 ^{-0.2} _{-0.55} | 5400 | 7050 | 550 | 720 | 16000 | 24000 | 0.0033 |
| 14 | K 14x18x10 | 18 | 10 ^{-0.2} _{-0.55} | 6900 | 8000 | 705 | 815 | 16000 | 24000 | 0.0046 |

Cage and roller type needle roller bearings series K

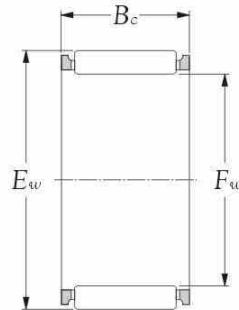

| Inner bore F_w mm | Bearing number | Principal dimensions | | Basic load ratings | | | | Max runout speed | | Weight kg. |
|---------------------------|----------------|----------------------|-------------------------------------|--------------------|------------------------|---------------------|------------------------|------------------|--------------|---------------|
| | | E_w mm | B_c mm | Dynamic C N | static C_o kgf | Dynamic C kgf | static C_o kgf | grease r/min | oil r/min | |
| 14 | K 14x18x11 | 18 | 11 ^{-0.2} _{-0.55} | 7600 | 9050 | 775 | 925 | 16000 | 24000 | 0.0053 |
| 14 | K 14x18x13 | 18 | 13 ^{-0.2} _{-0.55} | 8300 | 10100 | 845 | 1030 | 16000 | 24000 | 0.0063 |
| 14 | K 14x18x17 | 18 | 17 ^{-0.2} _{-0.55} | 10900 | 14400 | 1120 | 1470 | 16000 | 24000 | 0.0081 |
| 14 | K 14x19x13 | 19 | 13 ^{-0.2} _{-0.55} | 8950 | 9650 | 915 | 985 | 16000 | 24000 | 0.0080 |
| 14 | K 14x20x12 | 20 | 12 ^{-0.2} _{-0.55} | 9350 | 9150 | 955 | 930 | 16000 | 24000 | 0.0095 |
| 14 | K 14x20x17 | 20 | 17 ^{-0.2} _{-0.55} | 13500 | 14600 | 1370 | 1490 | 16000 | 24000 | 0.0140 |
| 15 | K 15x18x14 | 18 | 14 ^{-0.2} _{-0.55} | 7850 | 11600 | 800 | 1190 | 15000 | 23000 | 0.0060 |
| 15 | K 15x19x17 | 19 | 17 ^{-0.2} _{-0.55} | 10900 | 14600 | 1110 | 1490 | 15000 | 23000 | 0.0090 |
| 15 | K 15x20x13 | 20 | 13 ^{-0.2} _{-0.55} | 10100 | 11500 | 1030 | 1170 | 15000 | 23000 | 0.0088 |
| 15 | K 15x21x15 | 21 | 15 ^{-0.2} _{-0.55} | 11900 | 12500 | 1210 | 1280 | 15000 | 23000 | 0.0130 |
| 15 | K 15x21x21 | 21 | 21 ^{-0.2} _{-0.55} | 16500 | 19100 | 1680 | 1950 | 15000 | 23000 | 0.0170 |
| 16 | K 16x20x10 | 20 | 10 ^{-0.2} _{-0.55} | 7500 | 9250 | 765 | 945 | 15000 | 23000 | 0.0057 |
| 16 | K 16x20x11 | 20 | 11 ^{-0.2} _{-0.55} | 8300 | 10500 | 845 | 1070 | 15000 | 23000 | 0.0061 |
| 16 | K 16x20x13 | 20 | 13 ^{-0.2} _{-0.55} | 9050 | 11800 | 925 | 1200 | 15000 | 23000 | 0.0071 |
| 16 | K 16x22x12 | 22 | 12 ^{-0.2} _{-0.55} | 11700 | 12500 | 1190 | 1280 | 15000 | 23000 | 0.0100 |
| 16 | K 16x22x17 | 22 | 17 ^{-0.2} _{-0.55} | 14400 | 16400 | 1470 | 1670 | 15000 | 23000 | 0.0150 |
| 16 | K 16x22x20 | 22 | 20 ^{-0.2} _{-0.55} | 16000 | 18800 | 1640 | 1920 | 15000 | 23000 | 0.0170 |
| 17 | K 17x21x15 | 21 | 15 ^{-0.2} _{-0.55} | 10400 | 14400 | 1060 | 1460 | 15000 | 22000 | 0.0089 |
| 17 | K 17x21x17 | 21 | 17 ^{-0.2} _{-0.55} | 11800 | 16900 | 1210 | 1720 | 15000 | 22000 | 0.0095 |
| 17 | K 17x22x20 | 22 | 20 ^{-0.2} _{-0.55} | 14700 | 19200 | 1500 | 1960 | 15000 | 22000 | 0.0150 |
| 17 | K 17x23x17 | 23 | 17 ^{-0.2} _{-0.55} | 14400 | 16500 | 1460 | 1690 | 15000 | 22000 | 0.0160 |
| 18 | K 18x22x10 | 22 | 10 ^{-0.2} _{-0.55} | 7400 | 9400 | 755 | 955 | 14000 | 21000 | 0.0061 |
| 18 | K 18x22x13 | 22 | 13 ^{-0.2} _{-0.55} | 8900 | 11900 | 910 | 1210 | 14000 | 21000 | 0.0077 |
| 18 | K 18x22x17 | 22 | 17 ^{-0.2} _{-0.55} | 11700 | 17000 | 1200 | 1730 | 14000 | 21000 | 0.0110 |
| 18 | K 18x24x12 | 24 | 12 ^{-0.2} _{-0.55} | 12300 | 13800 | 1250 | 1410 | 14000 | 21000 | 0.0120 |
| 18 | K 18x24x13 | 24 | 13 ^{-0.2} _{-0.55} | 11600 | 12800 | 1180 | 1300 | 14000 | 21000 | 0.0130 |
| 18 | K 18x24x20 | 24 | 20 ^{-0.2} _{-0.55} | 17000 | 20900 | 1730 | 2130 | 14000 | 21000 | 0.0190 |
| 18 | K 18x25x17 | 25 | 17 ^{-0.2} _{-0.55} | 18000 | 20400 | 1830 | 2080 | 14000 | 21000 | 0.0190 |
| 18 | K 18x25x22 | 25 | 22 ^{-0.2} _{-0.55} | 22100 | 26600 | 2250 | 2710 | 14000 | 21000 | 0.0240 |
| 19 | K 19x23x13 | 23 | 13 ^{-0.2} _{-0.55} | 9650 | 13500 | 985 | 1370 | 14000 | 21000 | 0.0082 |
| 19 | K 19x23x17 | 23 | 17 ^{-0.2} _{-0.55} | 12700 | 19200 | 1300 | 1960 | 14000 | 21000 | 0.0110 |
| 20 | K 20x24x11 | 24 | 11 ^{-0.2} _{-0.55} | 9500 | 13400 | 970 | 1370 | 13000 | 20000 | 0.0072 |

Cage and roller type needle roller bearings series K

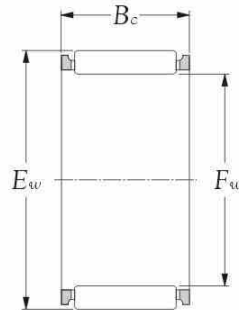

| Inner bore F_w mm | Bearing number | Principal dimensions | | Basic load ratings | | | | Max runout speed | | Weight kg. |
|---------------------------|----------------|----------------------|------------------------------|--------------------|------------------------|---------------------|------------------------|------------------|--------------|---------------|
| | | E_w mm | B_c mm | Dynamic C N | static C_o kgf | Dynamic C kgf | static C_o kgf | grease r/min | oil r/min | |
| 20 | K 20x26x12 | 26 | 12 ^{-0.2 -0.55} | 12900 | 15100 | 1320 | 1540 | 13000 | 20000 | 0.0130 |
| 20 | K 20x28x25 | 28 | 25 ^{-0.2 -0.55} | 27100 | 32500 | 2760 | 3300 | 13000 | 20000 | 0.0370 |
| 21 | K 21x25x13 | 25 | 13 ^{-0.2 -0.55} | 10300 | 15100 | 1050 | 1540 | 13000 | 19000 | 0.0090 |
| 21 | K 21x25x17 | 25 | 17 ^{-0.2 -0.55} | 13600 | 21500 | 1380 | 2200 | 13000 | 19000 | 0.0120 |
| 22 | K 22x26x13 | 26 | 13 ^{-0.2 -0.55} | 10200 | 15200 | 1040 | 1550 | 12000 | 18000 | 0.0094 |
| 22 | K 22x27x20 | 27 | 20 ^{-0.2 -0.55} | 17500 | 25900 | 1780 | 2640 | 12000 | 18000 | 0.0200 |
| 22 | K 22x28x17 | 28 | 17 ^{-0.2 -0.55} | 17700 | 23300 | 1810 | 2380 | 12000 | 18000 | 0.0200 |
| 22 | K 22x30x15 | 30 | 15 ^{-0.2 -0.55} | 19300 | 21700 | 1970 | 2210 | 12000 | 18000 | 0.0220 |
| 23 | K 23x28x24 | 28 | 24 ^{-0.2 -0.55} | 19800 | 31000 | 2020 | 3150 | 11000 | 17000 | 0.0230 |
| 24 | K 24x28x13 | 28 | 13 ^{-0.2 -0.55} | 10800 | 16800 | 1100 | 1710 | 11000 | 17000 | 0.0100 |
| 24 | K 24x28x17 | 28 | 17 ^{-0.2 -0.55} | 14300 | 23900 | 1460 | 2440 | 11000 | 17000 | 0.0130 |
| 24 | K 24x29x13 | 29 | 13 ^{-0.2 -0.55} | 12300 | 16900 | 1250 | 1720 | 11000 | 17000 | 0.0120 |
| 24 | K 24x30x17 | 30 | 17 ^{-0.2 -0.55} | 18400 | 25200 | 1880 | 2570 | 11000 | 17000 | 0.0220 |
| 25 | K 25x29x10 | 29 | 10 ^{-0.2 -0.55} | 8950 | 13300 | 910 | 1350 | 11000 | 16000 | 0.0083 |
| 25 | K 25x29x13 | 29 | 13 ^{-0.2 -0.55} | 10800 | 16900 | 1100 | 1720 | 11000 | 16000 | 0.0100 |
| 25 | K 25x30x13 | 30 | 13 ^{-0.2 -0.55} | 13200 | 18800 | 1350 | 1920 | 11000 | 16000 | 0.0130 |
| 25 | K 25x31x13 | 31 | 13 ^{-0.2 -0.55} | 15200 | 19900 | 1550 | 2030 | 11000 | 16000 | 0.0160 |
| 25 | K 25x31x14 | 31 | 14 ^{-0.2 -0.55} | 16500 | 22100 | 1680 | 2250 | 11000 | 16000 | 0.0180 |
| 25 | K 25x31x17 | 31 | 17 ^{-0.2 -0.55} | 18300 | 25300 | 1870 | 2580 | 11000 | 16000 | 0.0220 |
| 25 | K 25x31x21 | 31 | 21 ^{-0.2 -0.55} | 22500 | 33000 | 2290 | 3350 | 11000 | 16000 | 0.0260 |
| 26 | K 26x30x13 | 30 | 13 ^{-0.2 -0.55} | 11800 | 19200 | 1200 | 1960 | 10000 | 15000 | 0.0110 |
| 26 | K 26x30x17 | 30 | 17 ^{-0.2 -0.55} | 15500 | 27400 | 1580 | 2790 | 10000 | 15000 | 0.0150 |
| 26 | K 26x34x22 | 34 | 22 ^{-0.2 -0.55} | 24200 | 30000 | 2470 | 3050 | 10000 | 15000 | 0.0410 |
| 28 | K 28x32x17 | 32 | 17 ^{-0.2 -0.55} | 15300 | 27500 | 1560 | 2810 | 9500 | 14000 | 0.0170 |
| 28 | K 28x32x21 | 32 | 21 ^{-0.2 -0.55} | 18700 | 35500 | 1910 | 3650 | 9500 | 14000 | 0.0200 |
| 28 | K 28x33x13 | 33 | 13 ^{-0.2 -0.55} | 13900 | 20900 | 1420 | 2130 | 9500 | 14000 | 0.0150 |
| 28 | K 28x33x27 | 33 | 27 ^{-0.2 -0.55} | 28300 | 52000 | 2890 | 5300 | 9500 | 14000 | 0.0320 |
| 28 | K 28x34x14 | 34 | 14 ^{-0.2 -0.55} | 17500 | 24800 | 1790 | 2530 | 9500 | 14000 | 0.0200 |
| 28 | K 28x34x17 | 34 | 17 ^{-0.2 -0.55} | 18100 | 25800 | 1850 | 2630 | 9500 | 14000 | 0.0240 |
| 28 | K 28x35x16 | 35 | 16 ^{-0.2 -0.55} | 21200 | 28400 | 2160 | 2900 | 9500 | 14000 | 0.0290 |
| 28 | K 28x35x18 | 35 | 18 ^{-0.2 -0.55} | 21500 | 28900 | 2190 | 2950 | 9500 | 14000 | 0.0310 |
| 29 | K 29x34x27 | 34 | 27 ^{-0.2 -0.55} | 28100 | 52000 | 2870 | 5300 | 9500 | 14000 | 0.0330 |

Cage and roller type needle roller bearings series K

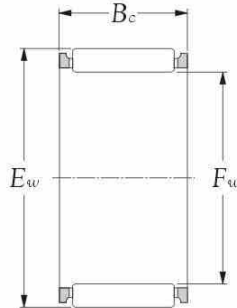

| Inner bore F_w mm | Bearing number | Principal dimensions | | Basic load ratings | | | | Max runout speed | | Weight kg. |
|---------------------------|----------------|----------------------|------------------------------|--------------------|------------------------|---------------------|------------------------|------------------|--------------|---------------|
| | | E_w mm | B_c mm | Dynamic C N | static C_o kgf | Dynamic C kgf | static C_o kgf | grease r/min | oil r/min | |
| 30 | K 30x37x16 | 37 | 16 ^{-0.2 -0.55} | 21900 | 30500 | 2230 | 3100 | 8500 | 13000 | 0.029 |
| 30 | K 30x37x18 | 37 | 18 ^{-0.2 -0.55} | 23300 | 33000 | 2370 | 3350 | 8500 | 13000 | 0.034 |
| 30 | K 30x38x18 | 38 | 18 ^{-0.2 -0.55} | 25000 | 33000 | 2550 | 3350 | 8500 | 13000 | 0.036 |
| 32 | K 32x37x13 | 37 | 13 ^{-0.2 -0.55} | 14500 | 23000 | 1480 | 2350 | 8500 | 13000 | 0.018 |
| 32 | K 32x38x26 | 38 | 26 ^{-0.2 -0.55} | 31500 | 54000 | 3200 | 5550 | 8500 | 13000 | 0.041 |
| 32 | K 32x39x16 | 39 | 16 ^{-0.2 -0.55} | 22600 | 32000 | 2310 | 3300 | 8500 | 13000 | 0.034 |
| 32 | K 32x39x18 | 39 | 18 ^{-0.2 -0.55} | 24000 | 35000 | 2450 | 3550 | 8500 | 13000 | 0.037 |
| 35 | K 35x40x13 | 40 | 13 ^{-0.2 -0.55} | 15200 | 25100 | 1550 | 2560 | 7500 | 11000 | 0.019 |
| 35 | K 35x40x17 | 40 | 17 ^{-0.2 -0.55} | 20000 | 36000 | 2040 | 3650 | 7500 | 11000 | 0.025 |
| 35 | K 35x41x14 | 41 | 14 ^{-0.2 -0.55} | 19400 | 30500 | 1980 | 3100 | 7500 | 11000 | 0.026 |
| 35 | K 35x41x15 | 41 | 15 ^{-0.2 -0.55} | 20900 | 33500 | 2130 | 3400 | 7500 | 11000 | 0.027 |
| 35 | K 35x42x16 | 42 | 16 ^{-0.2 -0.55} | 24100 | 36000 | 2450 | 3650 | 7500 | 11000 | 0.035 |
| 35 | K 35x42x18 | 42 | 18 ^{-0.2 -0.55} | 24700 | 37000 | 2510 | 3750 | 7500 | 11000 | 0.039 |
| 35 | K 35x42x20 | 42 | 20 ^{-0.2 -0.55} | 28500 | 44500 | 2910 | 4550 | 7500 | 11000 | 0.041 |
| 35 | K 35x42x30 | 42 | 30 ^{-0.2 -0.55} | 39500 | 68000 | 4050 | 6950 | 7500 | 11000 | 0.062 |
| 37 | K 37x42x13 | 42 | 13 ^{-0.2 -0.55} | 15900 | 27100 | 1620 | 2770 | 7500 | 11000 | 0.021 |
| 37 | K 37x44x18 | 44 | 18 ^{-0.2 -0.55} | 26300 | 41000 | 2680 | 4150 | 7500 | 11000 | 0.042 |
| 38 | K 38x43x17 | 43 | 17 ^{-0.2 -0.55} | 20900 | 38500 | 2130 | 3950 | 7500 | 11000 | 0.026 |
| 38 | K 38x43x27 | 43 | 27 ^{-0.2 -0.55} | 32000 | 67500 | 3300 | 6900 | 7500 | 11000 | 0.043 |
| 38 | K 38x46x32 | 46 | 32 ^{-0.2 -0.55} | 54000 | 95500 | 5500 | 9700 | 7500 | 11000 | 0.073 |
| 40 | K 40x45x13 | 45 | 13 ^{-0.2 -0.55} | 16500 | 29200 | 1680 | 2980 | 6500 | 10000 | 0.022 |
| 40 | K 40x45x17 | 45 | 17 ^{-0.2 -0.55} | 21800 | 41500 | 2220 | 4250 | 6500 | 10000 | 0.027 |
| 40 | K 40x45x21 | 45 | 21 ^{-0.2 -0.55} | 26700 | 54000 | 2720 | 5500 | 6500 | 10000 | 0.037 |
| 40 | K 40x45x27 | 45 | 27 ^{-0.2 -0.55} | 33500 | 72500 | 3400 | 7400 | 6500 | 10000 | 0.044 |
| 40 | K 40x46x17 | 46 | 17 ^{-0.2 -0.55} | 24600 | 43000 | 2500 | 4350 | 6500 | 10000 | 0.030 |
| 40 | K 40x47x18 | 47 | 18 ^{-0.2 -0.55} | 27700 | 45000 | 2820 | 4550 | 6500 | 10000 | 0.045 |
| 40 | K 40x47x20 | 47 | 20 ^{-0.2 -0.55} | 31000 | 51500 | 3150 | 5250 | 6500 | 10000 | 0.048 |
| 40 | K 40x48x20 | 48 | 20 ^{-0.2 -0.55} | 33000 | 51000 | 3350 | 5200 | 6500 | 10000 | 0.052 |
| 40 | K 40x48x25 | 48 | 25 ^{-0.2 -0.55} | 42500 | 71000 | 4350 | 7250 | 6500 | 10000 | 0.065 |
| 42 | K 42x47x17 | 47 | 17 ^{-0.2 -0.55} | 22100 | 43000 | 2250 | 4400 | 6500 | 9500 | 0.028 |
| 42 | K 42x47x27 | 47 | 27 ^{-0.2 -0.55} | 34000 | 75500 | 3450 | 7700 | 6500 | 9500 | 0.047 |
| 42 | K 42x48x17 | 48 | 17 ^{-0.2 -0.55} | 25700 | 46000 | 2630 | 4700 | 6500 | 9500 | 0.036 |

Cage and roller type needle roller bearings series K

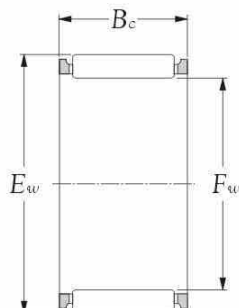

| Inner bore F_w mm | Bearing number | Principal dimensions | | Basic load ratings | | | | Max runout speed | | Weight kg. |
|---------------------------|----------------|----------------------|---------------------------------------|--------------------|------------------------|---------------------|------------------------|------------------|--------------|---------------|
| | | E_w mm | B_c mm | Dynamic C N | static C_o kgf | Dynamic C kgf | static C_o kgf | grease r/min | oil r/min | |
| 42 | K 42x50x20 | 50 | 20.0 ^{-0.2} _{-0.55} | 34000 | 53500 | 3450 | 5500 | 6500 | 9500 | 0.054 |
| 43 | K 43x48x17 | 48 | 17.0 ^{-0.2} _{-0.55} | 22000 | 43000 | 2240 | 4400 | 6500 | 9500 | 0.029 |
| 43 | K 43x48x27 | 48 | 27.0 ^{-0.2} _{-0.55} | 34000 | 75500 | 3450 | 7700 | 6500 | 9500 | 0.046 |
| 43 | K 43x50x18 | 50 | 18.0 ^{-0.2} _{-0.55} | 29100 | 49000 | 2960 | 5000 | 6500 | 9500 | 0.049 |
| 45 | K 45x49x19 | 49 | 19.0 ^{-0.2} _{-0.55} | 22100 | 52000 | 2260 | 5300 | 6000 | 9000 | 0.027 |
| 45 | K 45x50x27 | 50 | 27.0 ^{-0.2} _{-0.55} | 34500 | 78000 | 3500 | 7950 | 6000 | 9000 | 0.050 |
| 45 | K 45x52x18 | 52 | 18.0 ^{-0.2} _{-0.55} | 29700 | 51000 | 3000 | 5200 | 6000 | 9000 | 0.051 |
| 45 | K 45x52x21 | 52 | 21.0 ^{-0.2} _{-0.55} | 32000 | 56500 | 3300 | 5750 | 6000 | 9000 | 0.061 |
| 45 | K 45x53x20 | 53 | 20.0 ^{-0.2} _{-0.55} | 36000 | 59000 | 3650 | 6000 | 6000 | 9000 | 0.062 |
| 45 | K 45x53x25 | 53 | 25.0 ^{-0.2} _{-0.55} | 46500 | 82000 | 4700 | 8400 | 6000 | 9000 | 0.077 |
| 47 | K 47x52x17 | 52 | 17.0 ^{-0.2} _{-0.55} | 23200 | 47500 | 2360 | 4850 | 5500 | 8500 | 0.033 |
| 47 | K 47x52x27 | 52 | 27.0 ^{-0.2} _{-0.55} | 35500 | 83000 | 3650 | 8450 | 5500 | 8500 | 0.051 |
| 48 | K 48x54x19 | 54 | 19.0 ^{-0.2} _{-0.55} | 31000 | 61000 | 3150 | 6250 | 5500 | 8500 | 0.044 |
| 50 | K 50x55x13.5 | 55 | 13.5 ^{-0.2} _{-0.55} | 18100 | 35500 | 1850 | 3600 | 5500 | 8000 | 0.023 |
| 50 | K 50x55x20 | 55 | 20.0 ^{-0.2} _{-0.55} | 27900 | 62000 | 2850 | 6300 | 5500 | 8000 | 0.042 |
| 50 | K 50x55x27 | 55 | 27.0 ^{-0.2} _{-0.55} | 37000 | 88500 | 3750 | 9000 | 5500 | 8000 | 0.053 |
| 50 | K 50x55x30 | 55 | 30.0 ^{-0.2} _{-0.55} | 39500 | 97000 | 4050 | 9900 | 5500 | 8000 | 0.059 |
| 50 | K 50x57x18 | 57 | 18.0 ^{-0.2} _{-0.55} | 31500 | 57000 | 3200 | 5800 | 5500 | 8000 | 0.053 |
| 50 | K 50x58x20 | 58 | 20.0 ^{-0.2} _{-0.55} | 38500 | 67500 | 3950 | 6850 | 5500 | 8000 | 0.065 |
| 50 | K 50x58x25 | 58 | 25.0 ^{-0.2} _{-0.55} | 48500 | 90000 | 4950 | 9150 | 5500 | 8000 | 0.081 |
| 52 | K 52x58x19 | 58 | 19.0 ^{-0.2} _{-0.55} | 32000 | 65500 | 3250 | 6650 | 5000 | 7500 | 0.048 |
| 55 | K 55x60x17 | 60 | 17.0 ^{-0.2} _{-0.55} | 25800 | 58000 | 2630 | 5900 | 5000 | 7500 | 0.043 |
| 55 | K 55x60x20 | 60 | 20.0 ^{-0.2} _{-0.55} | 28800 | 66500 | 2940 | 6750 | 5000 | 7500 | 0.045 |
| 55 | K 55x60x30 | 60 | 30.0 ^{-0.2} _{-0.55} | 42000 | 108000 | 4300 | 11000 | 5000 | 7500 | 0.069 |
| 55 | K 55x61x19 | 61 | 19.0 ^{-0.2} _{-0.55} | 33000 | 69500 | 3350 | 7100 | 5000 | 7500 | 0.051 |
| 55 | K 55x61x20 | 61 | 20.0 ^{-0.2} _{-0.55} | 33000 | 69500 | 3350 | 7100 | 5000 | 7500 | 0.054 |
| 55 | K 55x61x30 | 61 | 30.0 ^{-0.2} _{-0.55} | 48000 | 113000 | 4900 | 11500 | 5000 | 7500 | 0.081 |
| 55 | K 55x62x18 | 62 | 18.0 ^{-0.2} _{-0.55} | 33500 | 63000 | 3400 | 6450 | 5000 | 7500 | 0.054 |
| 55 | K 55x63x20 | 63 | 20.0 ^{-0.2} _{-0.55} | 39000 | 70000 | 3950 | 7100 | 5000 | 7500 | 0.073 |
| 55 | K 55x63x25 | 63 | 25.0 ^{-0.2} _{-0.55} | 50500 | 97500 | 5150 | 9950 | 5000 | 7500 | 0.088 |
| 55 | K 55x63x32 | 63 | 32.0 ^{-0.2} _{-0.55} | 61000 | 125000 | 6200 | 12700 | 5000 | 7500 | 0.117 |
| 58 | K 58x64x19 | 64 | 19.0 ^{-0.2} _{-0.55} | 34000 | 73500 | 3450 | 7500 | 4700 | 7000 | 0.052 |

Cage and roller type needle roller bearings series K

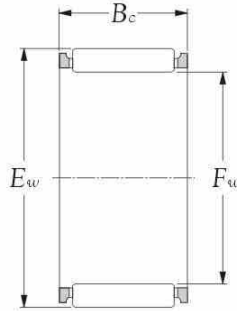

| Inner bore F_w mm | Bearing number | Principal dimensions | | Basic load ratings | | | | Max runout speed | | Weight kg. |
|---------------------------|----------------|----------------------|------------------------------|--------------------|------------------------|---------------------|------------------------|------------------|--------------|---------------|
| | | E_w mm | B_c mm | Dynamic C N | static C_o kgf | Dynamic C kgf | static C_o kgf | grease r/min | oil r/min | |
| 60 | K 60x65x20 | 65 | 20 ^{-0.2 -0.55} | 29800 | 71500 | 3050 | 7300 | 4300 | 6500 | 0.051 |
| 60 | K 60x65x30 | 65 | 30 ^{-0.2 -0.55} | 43500 | 116000 | 4450 | 11800 | 4300 | 6500 | 0.071 |
| 60 | K 60x66x19 | 66 | 19 ^{-0.2 -0.55} | 33500 | 73500 | 3450 | 7500 | 4300 | 6500 | 0.053 |
| 60 | K 60x66x20 | 66 | 20 ^{-0.2 -0.55} | 33500 | 73500 | 3450 | 7500 | 4300 | 6500 | 0.056 |
| 60 | K 60x66x30 | 66 | 30 ^{-0.2 -0.55} | 49000 | 119000 | 5000 | 12200 | 4300 | 6500 | 0.084 |
| 60 | K 60x68x15 | 68 | 15 ^{-0.2 -0.55} | 27200 | 45500 | 2780 | 4650 | 4300 | 6500 | 0.058 |
| 60 | K 60x68x20 | 68 | 20 ^{-0.2 -0.55} | 40000 | 75000 | 4100 | 7650 | 4300 | 6500 | 0.077 |
| 60 | K 60x68x23 | 68 | 23 ^{-0.2 -0.55} | 44500 | 85000 | 4500 | 8700 | 4300 | 6500 | 0.092 |
| 60 | K 60x68x25 | 68 | 25 ^{-0.2 -0.55} | 52000 | 105000 | 5300 | 10700 | 4300 | 6500 | 0.097 |
| 60 | K 60x68x27 | 68 | 27 ^{-0.2 -0.55} | 52000 | 105000 | 5300 | 10700 | 4300 | 6500 | 0.098 |
| 61 | K 61x66x20 | 66 | 20 ^{-0.2 -0.55} | 29700 | 71500 | 3050 | 7300 | 4300 | 6500 | 0.054 |
| 61 | K 61x66x30 | 66 | 30 ^{-0.2 -0.55} | 43500 | 116000 | 4400 | 11900 | 4300 | 6500 | 0.073 |
| 63 | K 63x70x21 | 70 | 21 ^{-0.2 -0.55} | 44500 | 95500 | 4500 | 9700 | 4300 | 6500 | 0.075 |
| 64 | K 64x70x16 | 70 | 16 ^{-0.2 -0.55} | 28400 | 60500 | 2900 | 6150 | 4300 | 6500 | 0.053 |
| 65 | K 65x70x20 | 70 | 20 ^{-0.2 -0.55} | 30500 | 75000 | 3100 | 7650 | 4000 | 6000 | 0.055 |
| 65 | K 65x70x30 | 70 | 30 ^{-0.2 -0.55} | 45000 | 124000 | 4600 | 12700 | 4000 | 6000 | 0.083 |
| 65 | K 65x73x23 | 73 | 23 ^{-0.2 -0.55} | 47000 | 94000 | 4800 | 9600 | 4000 | 6000 | 0.100 |
| 65 | K 65x73x30 | 73 | 30 ^{-0.2 -0.55} | 61000 | 132000 | 6200 | 13400 | 4000 | 6000 | 0.126 |
| 68 | K 68x74x20 | 74 | 20 ^{-0.2 -0.55} | 36000 | 83500 | 3700 | 8550 | 4000 | 6000 | 0.065 |
| 68 | K 68x74x30 | 74 | 30 ^{-0.2 -0.55} | 51500 | 133000 | 5250 | 13500 | 4000 | 6000 | 0.097 |
| 68 | K 68x75x21 | 75 | 21 ^{-0.2 -0.55} | 45500 | 101000 | 4600 | 10300 | 4000 | 6000 | 0.077 |
| 70 | K 70x76x20 | 76 | 20 ^{-0.2 -0.55} | 36500 | 86000 | 3700 | 8750 | 3700 | 5500 | 0.070 |
| 70 | K 70x76x30 | 76 | 30 ^{-0.2 -0.55} | 53000 | 139000 | 5400 | 14200 | 3700 | 5500 | 0.100 |
| 70 | K 70x77x21 | 77 | 21 ^{-0.2 -0.55} | 45000 | 101000 | 4600 | 10300 | 3700 | 5500 | 0.080 |
| 70 | K 70x78x23 | 78 | 23 ^{-0.2 -0.55} | 49500 | 103000 | 5050 | 10500 | 3700 | 5500 | 0.107 |
| 70 | K 70x78x30 | 78 | 30 ^{-0.2 -0.55} | 65500 | 149000 | 6700 | 15200 | 3700 | 5500 | 0.136 |
| 72 | K 72x79x21 | 79 | 21 ^{-0.2 -0.55} | 46500 | 106000 | 4750 | 10800 | 3700 | 5500 | 0.085 |
| 73 | K 73x79x30 | 79 | 30 ^{-0.2 -0.55} | 54500 | 146000 | 5550 | 14900 | 3700 | 5500 | 0.106 |
| 75 | K 75x81x30 | 81 | 30 ^{-0.2 -0.55} | 56000 | 152000 | 5700 | 15500 | 3700 | 5500 | 0.108 |
| 75 | K 75x82x21 | 82 | 21 ^{-0.2 -0.55} | 46000 | 106000 | 4700 | 10800 | 3700 | 5500 | 0.088 |
| 75 | K 75x83x23 | 83 | 23 ^{-0.2 -0.55} | 50500 | 109000 | 5150 | 11100 | 3700 | 5500 | 0.113 |
| 75 | K 75x83x30 | 83 | 30 ^{-0.2 -0.55} | 67500 | 157000 | 6850 | 16100 | 3700 | 5500 | 0.147 |

Cage and roller type needle roller bearings series K

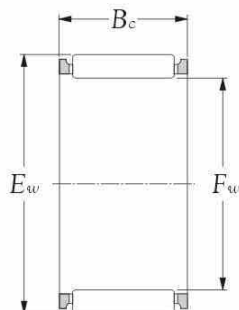

| Inner bore F_w mm | Bearing number | Principal dimensions | | Basic load ratings | | | | Max runout speed | | Weight kg. |
|---------------------------|----------------|----------------------|------------------------------|--------------------|--------------|---------------------|--------------|------------------------|------|---------------|
| | | E_w mm | B_c mm | Dynamic C N | static Co | Dynamic C kgf | static Co | grease oil r/min | | |
| 80 | K 80x86x20 | 86 | 20 ^{-0.2 -0.55} | 39000 | 98000 | 4000 | 10000 | 3300 | 5000 | 0.077 |
| 80 | K 80x86x30 | 86 | 30 ^{-0.2 -0.55} | 57000 | 159000 | 5800 | 16200 | 3300 | 5000 | 0.110 |
| 80 | K 80x88x23 | 88 | 23 ^{-0.2 -0.55} | 53000 | 118000 | 5400 | 12100 | 3300 | 5000 | 0.125 |
| 80 | K 80x88x26 | 88 | 26 ^{-0.2 -0.55} | 61000 | 142000 | 6250 | 14500 | 3300 | 5000 | 0.131 |
| 80 | K 80x88x30 | 88 | 30 ^{-0.2 -0.55} | 69000 | 66000 | 7050 | 17000 | 3300 | 5000 | 0.157 |
| 85 | K 85x92x30 | 92 | 30 ^{-0.2 -0.55} | 66000 | 176000 | 6750 | 18000 | 3100 | 4700 | 0.142 |
| 85 | K 85x93x27 | 93 | 27 ^{-0.2 -0.55} | 64000 | 153000 | 6500 | 15600 | 3100 | 4700 | 0.145 |
| 85 | K 85x93x30 | 93 | 30 ^{-0.2 -0.55} | 71000 | 175000 | 7200 | 17900 | 3100 | 4700 | 0.160 |
| 90 | K 90x97x20 | 97 | 20 ^{-0.2 -0.55} | 46000 | 113000 | 4700 | 11500 | 2900 | 4400 | 0.103 |
| 90 | K 90x97x30 | 97 | 30 ^{-0.2 -0.55} | 67500 | 184000 | 6850 | 18700 | 2900 | 4400 | 0.151 |
| 90 | K 90x98x26 | 98 | 26 ^{-0.2 -0.55} | 64000 | 157000 | 6550 | 16000 | 2900 | 4400 | 0.148 |
| 90 | K 90x98x27 | 98 | 27 ^{-0.2 -0.55} | 64000 | 157000 | 6550 | 16000 | 2900 | 4400 | 0.150 |
| 90 | K 90x98x30 | 98 | 30 ^{-0.2 -0.55} | 72500 | 184000 | 7400 | 18800 | 2900 | 4400 | 0.172 |
| 95 | K 95x102x21 | 102 | 21 ^{-0.2 -0.55} | 48000 | 122000 | 4900 | 12400 | 2800 | 4200 | 0.115 |
| 95 | K 95x102x31 | 102 | 31 ^{-0.2 -0.55} | 70500 | 199000 | 7200 | 20300 | 2800 | 4200 | 0.172 |
| 95 | K 95x103x27 | 103 | 27 ^{-0.2 -0.55} | 65500 | 165000 | 6700 | 16800 | 2800 | 4200 | 0.159 |
| 95 | K 95x103x30 | 103 | 30 ^{-0.2 -0.55} | 74000 | 193000 | 7550 | 19600 | 2800 | 4200 | 0.165 |
| 100 | K 100x107x21 | 107 | 21 ^{-0.2 -0.65} | 49000 | 127000 | 5000 | 12900 | 2700 | 4000 | 0.120 |
| 100 | K 100x107x31 | 107 | 31 ^{-0.2 -0.65} | 71500 | 207000 | 7300 | 21100 | 2700 | 4000 | 0.173 |
| 100 | K 100x108x27 | 108 | 27 ^{-0.2 -0.65} | 61000 | 153000 | 6250 | 15600 | 2700 | 4000 | 0.176 |
| 100 | K 100x108x30 | 108 | 30 ^{-0.2 -0.65} | 76000 | 201000 | 7700 | 20500 | 2700 | 4000 | 0.190 |
| 105 | K 105x112x21 | 112 | 21 ^{-0.2 -0.65} | 48500 | 127000 | 4950 | 12900 | 2500 | 3800 | 0.130 |
| 105 | K 105x112x31 | 112 | 31 ^{-0.2 -0.65} | 71000 | 207000 | 7250 | 21100 | 2500 | 3800 | 0.176 |
| 105 | K 105x113x30 | 113 | 30 ^{-0.2 -0.65} | 77500 | 210000 | 7900 | 21400 | 2500 | 3800 | 0.198 |
| 110 | K 110x117x24 | 117 | 24 ^{-0.2 -0.65} | 54500 | 149000 | 5550 | 15200 | 2400 | 3600 | 0.145 |
| 110 | K 110x117x34 | 117 | 34 ^{-0.2 -0.65} | 77500 | 235000 | 7900 | 24000 | 2400 | 3600 | 0.205 |
| 110 | K 110x118x30 | 118 | 30 ^{-0.2 -0.65} | 79000 | 219000 | 8050 | 22300 | 2400 | 3600 | 0.217 |
| 115 | K 115x123x27 | 123 | 27 ^{-0.2 -0.65} | 64000 | 170000 | 6550 | 17300 | 2300 | 3500 | 0.200 |
| 115 | K 115x125x34 | 125 | 34 ^{-0.2 -0.65} | 95000 | 241000 | 9700 | 24600 | 2300 | 3500 | 0.330 |
| 120 | K 120x127x24 | 127 | 24 ^{-0.2 -0.65} | 57500 | 165000 | 5850 | 16800 | 2200 | 3300 | 0.160 |
| 120 | K 120x127x34 | 127 | 34 ^{-0.2 -0.65} | 82000 | 260000 | 8350 | 26600 | 2200 | 3300 | 0.235 |
| 125 | K 125x133x35 | 133 | 35 ^{-0.2 -0.65} | 87000 | 260000 | 8900 | 26500 | 2100 | 3200 | 0.275 |

Cage and roller type needle roller bearings series K

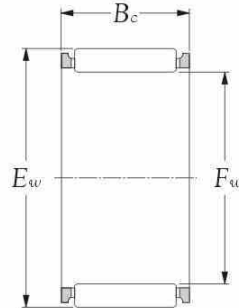

| Inner bore F_w mm | Bearing number | Principal dimensions | | Basic load ratings | | | | Max runout speed | | Weight kg (s). |
|---------------------------|----------------|----------------------|------------------------------|--------------------|------------------------|---------------------|------------------------|------------------|-------|-------------------|
| | | E_w mm | B_c mm | Dynamic C N | static C_o kgf | Dynamic C kgf | static C_o kgf | grease oil | r/min | |
| 125 | K 125x135x34 | 135 | 34 ^{-0.3 -0.65} | 100000 | 265000 | 10200 | 27000 | 2100 | 3200 | 0.350 |
| 130 | K 130x137x24 | 137 | 24 ^{-0.3 -0.65} | 59000 | 175000 | 6000 | 17900 | 2100 | 3100 | 0.170 |
| 130 | K 130x137x34 | 137 | 34 ^{-0.3 -0.65} | 84500 | 277000 | 8600 | 28300 | 2100 | 3100 | 0.240 |
| 135 | K 135x143x35 | 143 | 35 ^{-0.3 -0.65} | 92500 | 288000 | 9450 | 29400 | 2000 | 3000 | 0.300 |
| 135 | K 135x150x38 | 150 | 38 ^{-0.3 -0.65} | 145000 | 325000 | 14800 | 33500 | 2000 | 3000 | 0.590 |
| 145 | K 145x153x26 | 153 | 26 ^{-0.3 -0.65} | 72000 | 214000 | 7350 | 21800 | 1900 | 2800 | 0.250 |
| 145 | K 145x153x28 | 153 | 28 ^{-0.3 -0.65} | 80500 | 247000 | 8200 | 25200 | 1900 | 2800 | 0.252 |
| 145 | K 145x153x36 | 153 | 36 ^{-0.3 -0.65} | 100000 | 325000 | 10200 | 33000 | 1900 | 2800 | 0.335 |
| 150 | K 150x160x46 | 160 | 46 ^{-0.3 -0.65} | 149000 | 470000 | 15200 | 48000 | 1800 | 2700 | 0.550 |
| 155 | K 155x163x26 | 163 | 26 ^{-0.3 -0.65} | 73500 | 224000 | 7500 | 22800 | 1700 | 2600 | 0.270 |
| 155 | K 155x163x36 | 163 | 36 ^{-0.3 -0.65} | 102000 | 340000 | 10400 | 34500 | 1700 | 2600 | 0.355 |
| 160 | K 160x170x46 | 170 | 46 ^{-0.3 -0.65} | 155000 | 505000 | 15800 | 51500 | 1700 | 2500 | 0.570 |
| 165 | K 165x173x26 | 173 | 26 ^{-0.3 -0.65} | 79000 | 251000 | 8050 | 25600 | 1600 | 2400 | 0.290 |
| 165 | K 165x173x32 | 173 | 32 ^{-0.3 -0.65} | 97000 | 330000 | 9900 | 33500 | 1600 | 2400 | 0.340 |
| 165 | K 165x173x36 | 173 | 36 ^{-0.3 -0.65} | 109000 | 380000 | 11100 | 39000 | 1600 | 2400 | 0.375 |
| 170 | K 170x180x46 | 180 | 46 ^{-0.3 -0.65} | 160000 | 540000 | 16400 | 55000 | 1600 | 2400 | 0.620 |
| 175 | K 175x183x32 | 183 | 32 ^{-0.3 -0.65} | 101000 | 350000 | 10300 | 35500 | 1500 | 2300 | 0.360 |
| 185 | K 185x195x37 | 195 | 37 ^{-0.3 -0.65} | 131000 | 425000 | 13300 | 43500 | 1500 | 2200 | 0.560 |
| 195 | K 195x205x37 | 205 | 37 ^{-0.3 -0.65} | 135000 | 450000 | 13800 | 46000 | 1400 | 2100 | 0.620 |
| 210 | K 210x220x42 | 220 | 42 ^{-0.3 -0.65} | 156000 | 560000 | 15900 | 57000 | 1300 | 1900 | 0.740 |
| 220 | K 220x230x42 | 230 | 42 ^{-0.3 -0.65} | 161000 | 590000 | 16400 | 60000 | 1200 | 1800 | 0.790 |
| 240 | K 240x250x42 | 250 | 42 ^{-0.3 -0.65} | 167000 | 635000 | 17000 | 64500 | 1100 | 1700 | 0.850 |
| 265 | K 265x280x50 | 280 | 50 ^{-0.3 -0.65} | 256000 | 850000 | 26100 | 87000 | 1000 | 1500 | 1.810 |
| 285 | K 285x300x50 | 300 | 50 ^{-0.3 -0.65} | 268000 | 930000 | 27300 | 94500 | 950 | 1400 | 1.970 |



Drawn cup needle roller bearings



TECHNICAL SUPPLEMENT

T044 - 045

PRODUCT INFORMATION

P046 - 051

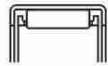

HK

P046 - 049



BK

P046 - 049

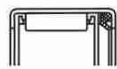

HK..RS

P050 - 051

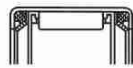

HK..2RS

P050 - 051

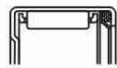

BK..RS

P050 - 051

1. Types and designs

KSM Drawn Cup Needle Roller Bearings can be classified into open-end and closed-end types according to the form of their outer ring. The open-end design is further subcategorized into the series HK (metric standard series). The closed-end design is further classified into series BK (metric standard series). Sealed **KSM** Drawn Cup Needle Roller Bearings (suffix RS or 2RS) having a synthetic rubber seal on one or both ends are pre-filled with lithium soap grease. The allowable operating temperature range with this bearing variant is -25 °C to +100 °C. Its rollers are shorter than those in an open-ended type of the same dimension, so its load rating is accordingly smaller.

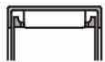

Fig. 1 Series HK

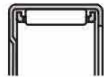

Fig. 2 Series BK

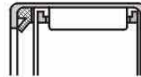

Fig. 3 Series HK..RS

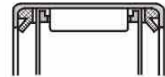

Fig. 4 Series HK..2RS

The cages used for drawn cup needle roller bearings are usually pressed-steel cages. Also, certain small drawn cup needle roller bearings use molded polyamide cages reinforced with glass fiber or carbon fiber.

2. Interpreting bearing numbers

As summarized in Fig. 5, the bearing numbers of **KSM** Drawn Cup Needle Roller Bearings comprise a series number, dimension code (inscribed enveloping circle diameter × width dimension), and suffix.

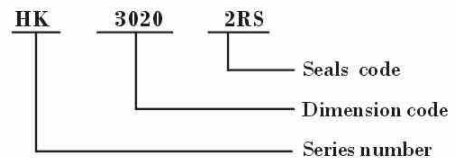

Fig. 5

3. Bearing fits

The fit of an **KSM** Drawn Cup Needle Roller Bearing to a housing is usually a tight fit where the inscribed enveloping circle diameter (Fw) of press-fit rollers satisfies ISO tolerance class F8. However, the inscribed enveloping circle diameter (Fw) of press-fit rollers varies with the material and rigidity of the housing. Therefore, actual bearing fit (interference) should be measured and determined through trials before the bearing is mounted.

If a housing has sufficient rigidity, selecting a fit to housing or shaft from Table 1 can result in an inscribed enveloping circle diameter (Fw) of press-fit rollers close to F8 and a radial clearance close to normal clearance.

Table 1 Fit to housing and shaft

| Series number | Housing | | Shaft | |
|---------------|---------|-------------|--------------------|-----------------|
| | Steel | Light alloy | Without inner ring | With inner ring |
| HK, BK | N6 (N7) | R6 (R7) | h5 (h6) | K5 (j6) |

4. Housing bore accuracy

Because the outer ring has a thinner wall, the performance of drawn cup needle roller bearings is significantly affected by the surface roughness and the dimensional and form accuracy of the housing bore to which a bearing is press-fit. The housing bore must satisfy the accuracy of Table 2.

5. Bearing tolerances and measuring methods

The outer ring of a drawn cup needle roller bearing is thin-walled. Therefore, some deformation of the outer ring unavoidably develops during the manufacturing process, particularly during heat treatment. However, when the outer ring is press-fit into a correctly dimensioned housing, the deformation is corrected, restoring the design functions of the outer ring. For this reason, measuring the dimensional accuracy of a drawn cup needle roller bearing before it is press-fit is meaningless. Therefore, its accuracy is evaluated by measuring its inscribed enveloping circle diameter (F_{av}) after it has been press-fit into a ring gauge of correct dimensions (wall thickness 20 mm or greater). The tolerances of the bore diameter of the ring gauges and the inscribed enveloping circle diameter (F_{av}) are given in Tables 3, which apply to the series HK and BK (standard metric series). When measuring the inscribed enveloping circle diameter (F_{av}) with a plug gauge, the dimension at GO side must satisfy "Low" tolerance for inscribed enveloping circle diameter, and that at NO GO side must satisfy "Height" tolerance plus 2 μm . These values comply with the relevant ISO standard.

Table 2 Recommended fits

| Characteristics | Tolerance |
|--------------------------|-------------|
| Circularity (max.) | IT4 or less |
| Cylindricity (max.) | IT4 or less |
| Surface roughness (max.) | 1.6a |

Table 3 Enveloping circle diameter tolerance (series HK and BK) (Unit: mm)

| Enveloping circle dia. F_{av} | Outside dia. of outer ring D | Ring gauge bore dia. | Enveloping circle dia. tolerance | |
|------------------------------------|-----------------------------------|----------------------|----------------------------------|--------|
| | | | High | low |
| 3 | 6.5 | 6.4840 | 3.016 | 3.006 |
| 4 | 8 | 7.9840 | 4.022 | 4.010 |
| 5 | 9 | 8.9840 | 5.022 | 5.010 |
| 6 | 10 | 9.9840 | 6.022 | 6.010 |
| 7 | 11 | 10.980 | 7.028 | 7.013 |
| 8 | 12 | 11.980 | 8.028 | 8.013 |
| 9 | 13 | 12.980 | 9.028 | 9.013 |
| 10 | 14 | 13.980 | 10.028 | 10.013 |
| 12 | 16 | 15.980 | 12.034 | 12.016 |
| 12 | 18 | 17.980 | 12.034 | 12.016 |
| 13 | 19 | 18.976 | 13.034 | 13.016 |
| 14 | 20 | 19.976 | 14.034 | 14.016 |
| 15 | 21 | 20.976 | 15.034 | 15.016 |
| 16 | 22 | 21.976 | 16.034 | 16.016 |
| 17 | 23 | 22.976 | 17.034 | 17.016 |
| 18 | 24 | 23.976 | 18.034 | 18.016 |
| 20 | 26 | 25.976 | 20.041 | 20.020 |
| 22 | 28 | 27.976 | 22.041 | 22.020 |
| 25 | 32 | 31.972 | 25.041 | 25.020 |
| 28 | 35 | 34.972 | 28.041 | 28.020 |
| 30 | 37 | 36.972 | 30.041 | 30.020 |
| 35 | 42 | 41.972 | 35.050 | 35.025 |
| 40 | 47 | 46.972 | 40.050 | 40.025 |
| 45 | 52 | 51.967 | 45.050 | 45.025 |
| 50 | 58 | 57.967 | 50.050 | 50.025 |
| 55 | 63 | 62.967 | 55.060 | 55.030 |
| 60 | 68 | 67.967 | 60.060 | 60.030 |

Drawn cup needle roller bearings series HK., BK..

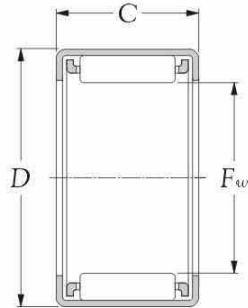

Type HK

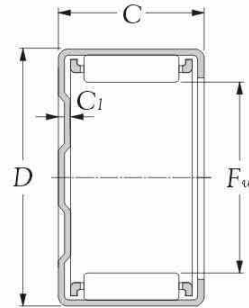

Type BK

| Inner bore F_w mm | Bearing number | | Principal dimensions | | | Basic load ratings | | | | Max runout speed | | Appropriate inner ring (as a reference) | Weight kg. |
|---------------------------|-----------------|-------------------|----------------------|-------------------------------|-----------------------------|--------------------|-----------------|----------------|-----------------|------------------|-------|--|---------------|
| | Open end design | Closed end design | D | C <small>0.02 mm</small> | C_l <small>max</small> | dynamic C | static C_o | dynamic C | static C_o | grease | oil | | |
| | | | | | | N | | | | r/min | | | |
| 3 | HK 0306 | - | 6.5 | 6 | - | 1250 | 835 | 128 | 85 | 33000 | 50000 | - | 0.0006 |
| 3 | - | BK 0306 | 6.5 | 6 | 0.8 | 1250 | 835 | 128 | 85 | 33000 | 50000 | - | 0.0007 |
| 4 | HK 0408 | - | 8.0 | 8 | - | 1770 | 1270 | 180 | 129 | 30000 | 45000 | - | 0.0016 |
| 4 | - | BK 0408 | 8.0 | 8 | 1.6 | 1770 | 1270 | 180 | 129 | 30000 | 45000 | - | 0.0018 |
| 5 | HK 0509 | - | 9.0 | 9 | - | 2640 | 2190 | 269 | 224 | 27000 | 40000 | - | 0.0019 |
| 5 | - | BK 0509 | 9.0 | 9 | 1.6 | 2640 | 2190 | 269 | 224 | 27000 | 40000 | - | 0.0021 |
| 6 | HK 0609 | - | 10.0 | 9 | - | 2660 | 2280 | 272 | 233 | 25000 | 37000 | - | 0.0022 |
| 6 | - | BK 0609 | 10.0 | 9 | 1.6 | 2660 | 2280 | 272 | 233 | 25000 | 37000 | - | 0.0024 |
| 7 | HK 0709 | - | 11.0 | 9 | - | 3400 | 3250 | 345 | 330 | 23000 | 34000 | - | 0.0025 |
| 7 | - | BK 0709 | 11.0 | 9 | 1.6 | 3400 | 3250 | 345 | 330 | 23000 | 34000 | - | 0.0027 |
| 8 | HK 0810 | - | 12.0 | 10 | - | 3850 | 3950 | 395 | 400 | 20000 | 30000 | IR 5x8x12 | 0.0032 |
| 8 | - | BK 0810 | 12.0 | 10 | 1.6 | 3850 | 3950 | 395 | 400 | 20000 | 30000 | IR 5x8x12 | 0.0034 |
| 9 | HK 0910 | - | 13.0 | 10 | - | 4600 | 5050 | 465 | 515 | 18000 | 27000 | IR 6x9x12 | 0.0035 |
| 9 | - | BK 0910 | 13.0 | 10 | 1.6 | 4600 | 5050 | 465 | 515 | 18000 | 27000 | IR 6x9x12 | 0.0039 |
| 9 | HK 0912 | - | 13.0 | 12 | - | 5650 | 6650 | 575 | 680 | 18000 | 27000 | IR 6x9x12 | 0.0042 |
| 9 | - | BK 0912 | 13.0 | 12 | 1.6 | 5650 | 6650 | 575 | 680 | 18000 | 27000 | IR 6x9x12 | 0.0045 |
| 10 | HK 1010 | - | 14.0 | 10 | - | 4500 | 5100 | 460 | 520 | 16000 | 24000 | IR 7x10x10.5 | 0.0038 |
| 10 | - | BK 1010 | 14.0 | 10 | 1.6 | 4500 | 5100 | 460 | 520 | 16000 | 24000 | IR 7x10x10.5 | 0.0042 |
| 10 | HK 1012 | - | 14.0 | 12 | - | 5900 | 7250 | 605 | 735 | 16000 | 24000 | IR 7x1x16 | 0.0045 |
| 10 | - | BK 1012 | 14.0 | 12 | 1.6 | 5900 | 7250 | 605 | 735 | 16000 | 24000 | IR 7x10x16 | 0.0050 |
| 10 | HK 1015 | - | 14.0 | 15 | - | 7100 | 9150 | 725 | 935 | 16000 | 24000 | IR 7x10x16 | 0.0056 |
| 10 | - | BK 1015 | 14.0 | 15 | 1.6 | 7100 | 9150 | 725 | 935 | 16000 | 24000 | IR 7x10x16 | 0.0062 |
| 12 | HK 1210 | - | 16.0 | 10 | - | 5050 | 6250 | 515 | 635 | 13000 | 20000 | IR 8x12x10.5 | 0.0046 |
| 12 | - | BK 1210 | 16.0 | 10 | 1.6 | 5050 | 6250 | 515 | 635 | 13000 | 20000 | IR 8x12x10.5 | 0.0052 |
| 12 | HK 1212 | - | 18.0 | 12 | - | 6600 | 7300 | 675 | 745 | 13000 | 20000 | IR 8x12x12.5 | 0.0091 |
| 12 | - | BK 1212 | 18.0 | 12 | 2.7 | 6600 | 7300 | 675 | 745 | 13000 | 20000 | IR 8x12x12.5 | 0.0100 |
| 13 | HK 1312 | - | 19.0 | 12 | - | 7300 | 8450 | 745 | 865 | 12000 | 18000 | IR 10x13x12.5 | 0.0100 |
| 13 | - | BK 1312 | 19.0 | 12 | 2.7 | 7300 | 8450 | 745 | 865 | 12000 | 18000 | IR 10x13x12.5 | 0.0110 |
| 14 | HK 1412 | - | 20.0 | 12 | - | 7200 | 8500 | 735 | 865 | 11000 | 17000 | IR 10x14x13 | 0.0110 |
| 14 | - | BK 1412 | 20.0 | 12 | 2.7 | 7200 | 8500 | 735 | 865 | 11000 | 17000 | IR 10x14x13 | 0.0120 |
| 14 | HK 1416 | - | 20.0 | 16 | - | 10700 | 14000 | 1090 | 1430 | 11000 | 17000 | - | 0.0150 |
| 14 | - | BK 1416 | 20.0 | 16 | 2.7 | 10700 | 14000 | 1090 | 1430 | 11000 | 17000 | - | 0.0160 |

Drawn cup needle roller bearings series HK., BK..

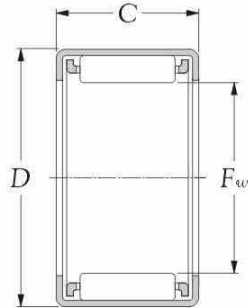

Type HK

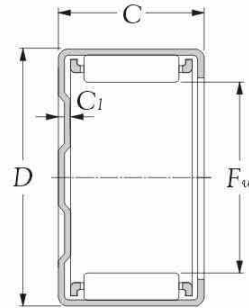

Type BK

| Inner bore F_w mm | Bearing number | | Principal dimensions | | | Basic load ratings | | | | Max runout speed | | Appropriate inner ring (as a reference) | Weight kg. |
|---------------------------|-----------------|-------------------|----------------------|-------------------------------|-----------------------------|--------------------|-------|------------|-------|------------------|-------|--|---------------|
| | Open end design | Closed end design | D | C <small>0,02 mm</small> | C_1 <small>max</small> | C N | C_0 | C kgf | C_0 | grease r/min | oil | | |
| 15 | HK 1512 | - | 21 | 12 | - | 7500 | 9100 | 765 | 930 | 11000 | 16000 | IR 12x15x12.5 | 0.011 |
| 15 | - | BK 1512 | 21 | 12 | 2.7 | 7500 | 9100 | 765 | 930 | 11000 | 16000 | IR 12x15x12.5 | 0.013 |
| 15 | HK 1516 | - | 21 | 16 | - | 10700 | 14400 | 1090 | 1470 | 11000 | 16000 | IR 12x15x16.5 | 0.015 |
| 15 | - | BK 1516 | 21 | 16 | 2.7 | 10700 | 14400 | 1090 | 1470 | 11000 | 16000 | IR 12x15x16.5 | 0.017 |
| 16 | HK 1612 | - | 22 | 12 | - | 7750 | 9700 | 795 | 990 | 10000 | 15000 | IR 12x16x13 | 0.012 |
| 16 | - | BK 1612 | 22 | 12 | 2.7 | 7750 | 9700 | 795 | 990 | 10000 | 15000 | IR 12x16x13 | 0.014 |
| 16 | HK 1616 | - | 22 | 16 | - | 11100 | 15300 | 1130 | 1570 | 10000 | 15000 | IR 12x16x20 | 0.016 |
| 16 | - | BK 1616 | 22 | 16 | 2.7 | 11100 | 15300 | 1130 | 1570 | 10000 | 15000 | IR 12x16x20 | 0.018 |
| 17 | HK 1712 | - | 23 | 12 | - | 8500 | 11100 | 865 | 1130 | 9500 | 14000 | - | 0.012 |
| 17 | - | BK 1712 | 23 | 12 | 2.7 | 8500 | 11100 | 865 | 1130 | 9500 | 14000 | - | 0.015 |
| 18 | HK 1812 | - | 24 | 12 | - | 8300 | 10900 | 845 | 1110 | 8500 | 13000 | IR 15x18x12.5 | 0.013 |
| 18 | - | BK 1812 | 24 | 12 | 2.7 | 8300 | 10900 | 845 | 1110 | 8500 | 13000 | IR 15x18x12.5 | 0.015 |
| 18 | HK 1816 | - | 24 | 16 | - | 11800 | 17300 | 1210 | 1760 | 8500 | 13000 | IR 15x18x16.5 | 0.018 |
| 18 | - | BK 1816 | 24 | 16 | 2.7 | 11800 | 17300 | 1210 | 1760 | 8500 | 13000 | IR 15x18x16.5 | 0.020 |
| 20 | HK 2012 | - | 26 | 12 | - | 9250 | 13000 | 945 | 1330 | 8000 | 12000 | IR 15x20x13 | 0.014 |
| 20 | - | BK 2012 | 26 | 12 | 2.7 | 9250 | 13000 | 945 | 1330 | 8000 | 12000 | IR 15x20x13 | 0.017 |
| 20 | HK 2016 | - | 26 | 16 | - | 13000 | 20100 | 1320 | 2050 | 8000 | 12000 | IR 17x20x16.5 | 0.019 |
| 20 | - | BK 2016 | 26 | 16 | 2.7 | 13000 | 20100 | 1320 | 2050 | 8000 | 12000 | IR 17x20x16.5 | 0.022 |
| 20 | HK 2020 | - | 26 | 20 | - | 16400 | 27100 | 1670 | 2760 | 8000 | 12000 | IR 17x20x20.5 | 0.024 |
| 20 | - | BK 2020 | 26 | 20 | 2.7 | 16400 | 27100 | 1670 | 2760 | 8000 | 12000 | IR 17x20x20.5 | 0.027 |
| 22 | HK 2212 | - | 28 | 12 | - | 9750 | 14300 | 995 | 1460 | 7500 | 11000 | IR 17x22x13 | 0.013 |
| 22 | - | BK 2212 | 28 | 12 | 2.7 | 9750 | 14300 | 995 | 1460 | 7500 | 11000 | IR 17x22x13 | 0.015 |
| 22 | HK 2216 | - | 28 | 16 | - | 13600 | 22100 | 1390 | 2250 | 7500 | 11000 | IR 17x22x18 | 0.021 |
| 22 | - | BK 2216 | 28 | 16 | 2.7 | 13600 | 22100 | 1390 | 2250 | 7500 | 11000 | IR 17x22x18 | 0.024 |
| 22 | HK 2220 | - | 28 | 20 | - | 17200 | 29800 | 1760 | 3050 | 7500 | 11000 | IR 17x22x20.5 | 0.026 |
| 22 | - | BK 2220 | 28 | 20 | 2.7 | 17200 | 29800 | 1760 | 3050 | 7500 | 11000 | IR 17x22x20.5 | 0.030 |
| 25 | HK 2512 | - | 32 | 12 | - | 11800 | 16300 | 1200 | 1660 | 6500 | 9500 | IR 20x25x12.5 | 0.021 |
| 25 | - | BK 2512 | 32 | 12 | 2.7 | 11800 | 16300 | 1200 | 1660 | 6500 | 9500 | IR 20x25x12.5 | 0.023 |
| 25 | HK 2516 | - | 32 | 16 | - | 15900 | 24000 | 1620 | 2450 | 6500 | 9500 | IR 20x25x17 | 0.027 |
| 25 | - | BK 2516 | 32 | 16 | 2.7 | 15900 | 24000 | 1620 | 2450 | 6500 | 9500 | IR 20x25x17 | 0.031 |
| 25 | HK 2520 | - | 32 | 20 | - | 20300 | 33000 | 2070 | 3350 | 6500 | 9500 | IR 20x25x20.5 | 0.034 |
| 25 | - | BK 2520 | 32 | 20 | 2.7 | 20300 | 33000 | 2070 | 3350 | 6500 | 9500 | IR 20x25x20.5 | 0.039 |



Drawn cup needle roller bearings series HK., BK..

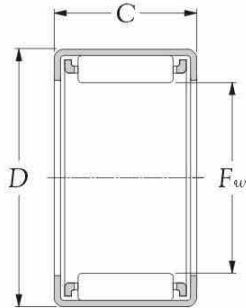

Type HK

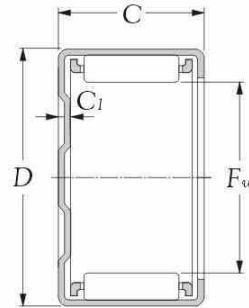

Type BK

| Inner bore <i>F_w</i> mm | Bearing number | | Principal dimensions | | | Basic load ratings | | | | Max runout speed | | Appropriate inner ring (as a reference) | Weight kg. |
|--|-----------------|-------------------|----------------------|------------------------|-----------------------------|--------------------|-----------------------------|-----------------|-----------------------------|------------------|--------------|--|---------------|
| | Open end design | Closed end design | <i>D</i> | <i>C</i> 0.02 mm | <i>C_l</i> max | <i>C</i> N | <i>C_o</i> kgf | <i>C</i> kgf | <i>C_o</i> kgf | grease r/min | oil r/min | | |
| 25 | HK 2526 | - | 32 | 26 | - | 26400 | 46000 | 2690 | 4700 | 6500 | 9500 | IR 20x25x26.5 | 0.045 |
| 25 | - | BK 2526 | 32 | 26 | 2.7 | 26400 | 46000 | 2690 | 4700 | 6500 | 9500 | IR 20x25x26.5 | 0.049 |
| 28 | HK 2816 | - | 35 | 16 | - | 17300 | 27600 | 1760 | 2820 | 5500 | 8500 | IR 22x28x17 | 0.030 |
| 28 | - | BK 2816 | 35 | 16 | 2.7 | 17300 | 27600 | 1760 | 2820 | 5500 | 8500 | IR 22x28x17 | 0.034 |
| 28 | HK 2820 | - | 35 | 20 | - | 21300 | 36000 | 2170 | 3700 | 5500 | 8500 | IR 22x28x20.5 | 0.038 |
| 28 | - | BK 2820 | 35 | 20 | 2.7 | 21300 | 36000 | 2170 | 3700 | 5500 | 8500 | IR 22x28x20.5 | 0.043 |
| 30 | HK 3012 | - | 37 | 12 | - | 13000 | 19500 | 1320 | 1990 | 5500 | 8000 | IR 25x30x12.5 | 0.024 |
| 30 | - | BK 3012 | 37 | 12 | 2.7 | 13000 | 19500 | 1320 | 1990 | 5500 | 8000 | IR 25x30x12.5 | 0.028 |
| 30 | HK 3016 | - | 37 | 16 | - | 18100 | 30000 | 1850 | 3050 | 5500 | 8000 | IR 25x30x17 | 0.032 |
| 30 | - | BK 3016 | 37 | 16 | 2.7 | 18100 | 30000 | 1850 | 3050 | 5500 | 8000 | IR 25x30x17 | 0.037 |
| 30 | HK 3020 | - | 37 | 20 | - | 22300 | 39500 | 2280 | 4000 | 5500 | 8000 | IR 25x30x20.5 | 0.040 |
| 30 | - | BK 3020 | 37 | 20 | 2.7 | 22300 | 39500 | 2280 | 4000 | 5500 | 8000 | IR 25x30x20.5 | 0.047 |
| 30 | HK 3026 | - | 37 | 26 | - | 29100 | 55000 | 2960 | 5650 | 5500 | 8000 | IR 25x30x26.5 | 0.053 |
| 30 | - | BK 3026 | 37 | 26 | 2.7 | 29100 | 55000 | 2960 | 5650 | 5500 | 8000 | IR 25x30x26.5 | 0.059 |
| 35 | HK 3512 | - | 42 | 12 | - | 14000 | 22800 | 1430 | 2320 | 4700 | 7000 | - | 0.028 |
| 35 | - | BK 3512 | 42 | 12 | 2.7 | 14000 | 22800 | 1430 | 2320 | 4700 | 7000 | - | 0.033 |
| 35 | HK 3516 | - | 42 | 16 | - | 19700 | 35000 | 2000 | 3600 | 4700 | 7000 | - | 0.037 |
| 35 | - | BK 3516 | 42 | 16 | 2.7 | 19700 | 35000 | 2000 | 3600 | 4700 | 7000 | - | 0.044 |
| 35 | HK 3520 | - | 42 | 20 | - | 24800 | 47500 | 2530 | 4850 | 4700 | 7000 | - | 0.046 |
| 35 | - | BK 3520 | 42 | 20 | 2.7 | 24800 | 47500 | 2530 | 4850 | 4700 | 7000 | - | 0.055 |
| 40 | HK 4012 | - | 47 | 12 | - | 15100 | 26000 | 1540 | 2660 | 4000 | 6000 | IR 35x40x12.5 | 0.031 |
| 40 | - | BK 4012 | 47 | 12 | 2.7 | 15100 | 26000 | 1540 | 2660 | 4000 | 6000 | IR 35x40x12.5 | 0.038 |
| 40 | HK 4016 | - | 47 | 16 | - | 21100 | 40000 | 2150 | 4100 | 4000 | 6000 | IR 35x40x17 | 0.041 |
| 40 | - | BK 4016 | 47 | 16 | 2.7 | 21100 | 40000 | 2150 | 4100 | 4000 | 6000 | IR 35x40x17 | 0.051 |
| 40 | HK 4020 | - | 47 | 20 | - | 25900 | 52500 | 2650 | 5350 | 4000 | 6000 | IR 35x40x20.5 | 0.052 |
| 40 | - | BK 4020 | 47 | 20 | 2.7 | 25900 | 52500 | 2650 | 5350 | 4000 | 6000 | IR 35x40x20.5 | 0.064 |
| 45 | HK 4516 | - | 52 | 16 | - | 21600 | 43000 | 2210 | 4400 | 3700 | 5500 | IR 40x45x17 | 0.046 |
| 45 | - | BK 4516 | 52 | 16 | 2.7 | 21600 | 43000 | 2210 | 4400 | 3700 | 5500 | IR 40x45x17 | 0.058 |
| 45 | HK 4520 | - | 52 | 20 | - | 27600 | 59000 | 2810 | 6000 | 3700 | 5500 | IR 40x45x20.5 | 0.058 |
| 45 | - | BK 4520 | 52 | 20 | 2.7 | 27600 | 59000 | 2810 | 6000 | 3700 | 5500 | IR 40x45x20.5 | 0.072 |
| 50 | HK 5020 | - | 58 | 20 | - | 31500 | 63000 | 3200 | 6450 | 3200 | 4800 | IR 40x50x22 | 0.072 |
| 50 | - | BK 5020 | 58 | 20 | 2.7 | 31500 | 63000 | 3200 | 6450 | 3200 | 4800 | IR 40x50x22 | 0.087 |

**Drawn cup needle roller bearings
series HK., BK..**

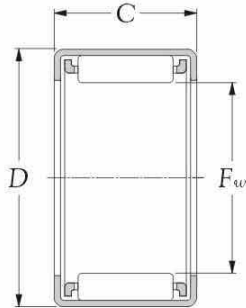

Type HK

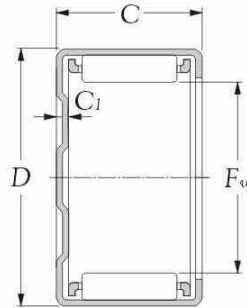

Type BK

| Inner bore F_w mm | Bearing number | | Principal dimensions | | | Basic load ratings | | | | Max runout speed | | Appropriate inner ring (as a reference) | Weight kg. |
|---------------------------|-----------------|-------------------|----------------------|----------------------------------|-----------------------------|---------------------|-----------------|-----------------------|-----------------|------------------|------|--|---------------|
| | Open end design | Closed end design | D | C <small>0.02</small> mm | C_1 <small>max</small> | dynamic C N | static C_o | dynamic C kgf | static C_o | grease r/min | oil | | |
| 50 | HK 5025 | - | 58 | 25 | - | 38500 | 82000 | 3900 | 8400 | 3200 | 4800 | IR 45x50x25.5 | 0.090 |
| 50 | - | BK 5025 | 58 | 25 | 2.7 | 38500 | 82000 | 3900 | 8400 | 3200 | 4800 | IR 45x50x25.5 | 0.109 |

Drawn cup needle roller bearings sealed type series **HK..RS, HK..2RS, BK..RS**

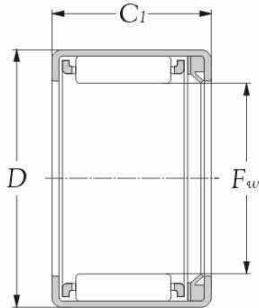

Type **HK..RS**
(Open end, single seal)

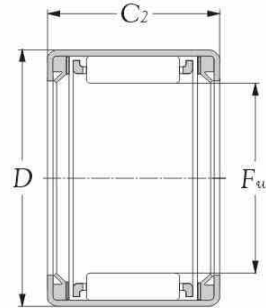

Type **HK..2RS**
(Open end, double seals)

| Inner bore F_{sw} mm | Bearing number | | | Principal dimensions | | | | Basic load ratings | | | |
|------------------------------|-------------------------|--------------------------|---------------------------|----------------------|-----------------------------|-----------------------------|--------------|--------------------|-----------------|----------------|-----------------|
| | open end single seal | open end double seals | closed end single seal | D | C_1 0 -0.02 mm | C_2 0 -0.02 mm | C_3 max | dynamic C | static C_0 | dynamic C | static C_0 |
| | | | | | | | | N | | Kgf | |
| 12 | HK 1214 RS | HK 1216 2RS | BK 1214 RS | 18 | 14 | 16 | 2.7 | 6600 | 7300 | 675 | 745 |
| 14 | HK 1414 RS | HK 1416 2RS | BK 1414 RS | 20 | 14 | 16 | 2.7 | 7200 | 8500 | 735 | 865 |
| 15 | HK 1514 RS | HK 1516 2RS | BK 1514 RS | 21 | 14 | 16 | 2.7 | 7500 | 9100 | 765 | 930 |
| 16 | HK 1614 RS | HK 1616 2RS | BK 1614 RS | 22 | 14 | 16 | 2.7 | 7750 | 9700 | 795 | 990 |
| 18 | HK 1814 RS | HK 1816 2RS | BK 1814 RS | 24 | 14 | 16 | 2.7 | 8300 | 10900 | 845 | 1110 |
| 20 | - | HK 2016 2RS | - | 26 | - | 16 | - | 9250 | 13000 | 945 | 1330 |
| 20 | HK 2018 RS | HK 2020 2RS | BK 2018 RS | 26 | 18 | 20 | 2.7 | 13000 | 20100 | 1320 | 2050 |
| 22 | - | HK 2216 2RS | - | 28 | - | 16 | - | 9750 | 14300 | 995 | 1460 |
| 22 | HK 2218 RS | HK 2220 2RS | BK 2218 RS | 28 | 18 | 20 | 2.7 | 13600 | 22100 | 1390 | 2250 |
| 25 | - | HK 2516 2RS | - | 32 | - | 16 | - | 11800 | 16300 | 1200 | 1660 |
| 25 | HK 2518 RS | HK 2520 2RS | BK 2518 RS | 32 | 18 | 20 | 2.7 | 15900 | 24000 | 1620 | 2450 |
| 28 | - | HK 2820 2RS | - | 35 | - | 20 | - | 17300 | 27600 | 1760 | 2820 |
| 30 | - | HK 3016 2RS | BK 3018 RS | 37 | - | 16 | - | 13000 | 19500 | 1320 | 1990 |
| 30 | HK 3018 RS | HK 3020 2RS | | 37 | 18 | 20 | 2.7 | 18100 | 30000 | 1850 | 3050 |
| 35 | - | HK 3516 2RS | - | 42 | - | 16 | - | 14000 | 22800 | 1430 | 2320 |
| 35 | HK 3518 RS | HK 3520 2RS | BK 3518 RS | 42 | 18 | 20 | 2.7 | 19700 | 35000 | 2000 | 3600 |
| 40 | - | HK 4016 2RS | - | 47 | - | 16 | - | 15100 | 26000 | 1540 | 2660 |
| 40 | HK 4018 RS | HK 4020 2RS | BK 4018 RS | 47 | 18 | 20 | 2.7 | 21100 | 40000 | 2150 | 4100 |
| 45 | HK 4518 RS | HK 4520 2RS | BK 4518 RS | 52 | 18 | 20 | 2.7 | 21600 | 43000 | 2210 | 4400 |
| 50 | HK 5022 RS | HK 5024 2RS | BK 5022 RS | 58 | 22 | 24 | 2.7 | 31500 | 63000 | 3200 | 6450 |

Drawn cup needle roller bearings sealed type
series HK..RS, HK..2RS, BK..RS

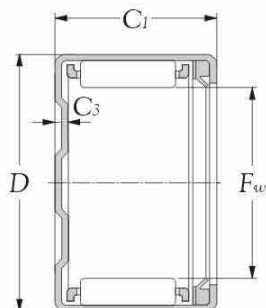

Type BK..RS
(Closed end, single seal)

| Max runout speed grease | Appropriate inner ring (as a reference) | | Weight kg. | | |
|----------------------------|--|---------------|-------------------------|--------------------------|---------------------------|
| | single seal | double seals | open end single seal | open end double seals | closed end single seal |
| 10000 | IR 9×12×16 | - | 0.011 | 0.012 | 0.012 |
| 10000 | IR 10×14×16 | IR 10×14×20 | 0.012 | 0.014 | 0.014 |
| 10000 | IR 12×15×16.5 | IR 12×15×16.5 | 0.013 | 0.014 | 0.014 |
| 10000 | IR 12×16×16 | IR 12×16×20 | 0.013 | 0.015 | 0.015 |
| 9000 | IR 15×18×16 | IR 15×18×17.5 | 0.015 | 0.017 | 0.017 |
| 8000 | - | IR 15×20×18 | - | 0.019 | - |
| 8000 | IR 17×20×20 | IR 17×20×20.5 | 0.021 | 0.024 | 0.024 |
| 7500 | - | IR 17×22×18 | - | 0.020 | - |
| 7500 | IR 17×22×20.5 | IR 17×22×23 | 0.024 | 0.026 | 0.027 |
| 6500 | - | IR 20×25×18D | - | 0.027 | - |
| 6500 | IR 20×25×20 | IR 20×25×23 | 0.031 | 0.033 | 0.035 |
| 5500 | - | IR 22×28×23 | - | 0.037 | - |
| 5500 | - | IR 25×30×18D | - | 0.027 | - |
| 5500 | IR 25×30×20 | IR 25×30×23 | 0.037 | 0.039 | 0.045 |
| 4600 | - | - | - | 0.036 | - |
| 4600 | - | - | 0.037 | 0.040 | 0.047 |
| 4000 | - | IR 35×40×17 | - | 0.041 | - |
| 4000 | IR 35×40×20 | - | 0.047 | 0.050 | 0.062 |
| 3600 | IR 40×45×20 | - | 0.054 | 0.057 | 0.072 |
| 3200 | IR 45×50×25 | IR 45×50×25.5 | 0.086 | 0.089 | 0.104 |





One-way clutches



TECHNICAL SUPPLEMENT

T054

PRODUCT INFORMATION

P055 - 056



HF

P055

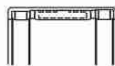

HFL

P056

1. Bearing materials

KSM Series HF one-way clutches have an outer ring formed by precision drawing of thin steel plate, and are capable of a clutching function only. In order to carry a radial load and rotate smoothly, a one-way clutch must have bearings on both sides.

KSM Engineering.

All of **KSM**'s series HF one-way clutches use a polyamide resin cage that supports a leaf spring. The leaf spring in turn forces the needle rollers to the wedge section formed between the outer ring cam way and the shaft.

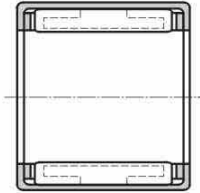

Fig. 1 Series HF

2. Interpreting clutch numbers

Clutch numbers of **KSM** one-way clutches comprise a series number and dimension code.

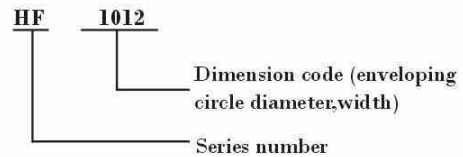

Fig. 2

3. Lubrication

Oil is the best lubrication for **KSM** one-way clutches. However, they are supplied prefilled with adequate grease, as they are often grease-lubricated. Under normal operating conditions, this grease does not need replenishment. Note, however, that excessive grease can inhibit reliable clutch operation.

4. Mounting practices

Using a press-fit mandrel is convenient when assembling one-way clutch as illustrated in Fig.7. With series HF be sure to press-fit the clutch with its inscription side placed onto the shoulder on the mandrel. With series HFL, it is important to press-fit the clutch by using a special tool that presses the outer ring without pressing the oil retaining bearing. When assembling, be sure not to pry the outer ring or directly hit the outer ring with a hammer. Be sure place the appropriate tool on the face of the outer ring when press-fitting the clutch. When mass-producing clutches with a press, using a mandrel equipped with an O-ring facilitates insertion of the one-way clutch by keeping it from falling out. Turning the shaft in the direction in which the clutch slips facilitates the assembly. If this can't be done, providing a tapered guide (chamfered) on the shaft end will also facilitate assembly.

Transmission direction (direction of engagement)

The clutch is engaged when the outer ring (housing) is turned relative to the shaft in the direction indicated by the arrow mark. With the series HF clutch, the mark is on the rib of the outer ring.

One-way clutch miniature type series HF

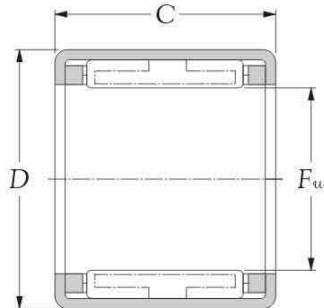

| Inner bore F_w mm | Bearing number | Principal dimensions | | Torque capacity | | Part number by radial load | | Weight kg. |
|---------------------------|----------------|----------------------|-----------|-----------------|---------------------|----------------------------|--------------------------|---------------|
| | | D mm | C mm | $N \cdot m$ | $kgf \cdot m$ Md | needle roller bearing | oil retaining bearing | |
| 6 | HF 0612 | 10 | 12 | 1.76 | 0.18 | HK 0609 T2 | B-S 6-22 | 0.0030 |
| 8 | HF 0812 | 12 | 12 | 3.15 | 0.32 | HK 0810 | B-S 8-25 | 0.0035 |
| 10 | HF 1012 | 14 | 12 | 5.30 | 0.54 | HK 1010 | B-S 10-21 | 0.0040 |
| 12 | HF 1216 | 18 | 16 | 12.20 | 1.24 | HK 1212 | B-S 12-32 | 0.0116 |
| 14 | HF 1416 | 20 | 16 | 17.30 | 1.76 | HK 1412 | B-S 14-13 | 0.0130 |
| 16 | HF 1616 | 22 | 16 | 20.50 | 2.09 | HK 1612 | B-S 16-13 | 0.0140 |
| 18 | HF 1816 | 24 | 16 | 24.10 | 2.46 | HK 1812 | B-S 18-8 | 0.0155 |
| 20 | HF 2016 | 26 | 16 | 28.50 | 2.91 | HK 2012 | B-S 20-19 | 0.0170 |
| 25 | HF 2520 | 32 | 20 | 66.00 | 6.73 | HK 2512 | B-S 25-11 | 0.0309 |
| 30 | HF 3020 | 37 | 20 | 90.00 | 9.18 | HK 3012 | B-S 30-19 | 0.0360 |
| 35 | HF 3520 | 42 | 20 | 121.00 | 12.30 | HK 3512 | B-S 35-7 | 0.0400 |

Drawn cup needle clutch series HFL

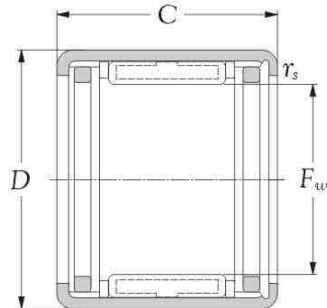

| Inner bore F_w mm | Bearing number | Principal dimensions | | Basic load ratings | | Limiting speed | | Rotation torque Nm |
|---------------------------|----------------|----------------------|-----------|---------------------|----------------------|----------------|-------------------|-----------------------|
| | | D mm | C mm | dynamic C N | static C_0 N | n rpm | n_l^{**} rpm | |
| 4 | HFL 0408 | 8 | 8 | 1270 | 1740 | 34000 | 14000 | 0.34 |
| 6 | HFL 0615 | 10 | 15 | 1650 | 2030 | 23000 | 13000 | 1.76 |
| 8 | HFL 0822 | 12 | 22 | 4050 | 4150 | 17000 | 12000 | 3.15 |
| 10 | HFL 1022 | 14 | 22 | 4300 | 4650 | 14000 | 11000 | 5.30 |
| 12 | HFL 1226 | 18 | 26 | 6300 | 6500 | 11000 | 8000 | 12.20 |
| 14 | HFL 1426 | 20 | 26 | 6300 | 6500 | 9500 | 8000 | 17.30 |
| 16 | HFL 1626 | 22 | 26 | 7300 | 8400 | 8500 | 7500 | 20.50 |
| 18 | HFL 1826 | 24 | 26 | 8200 | 10300 | 7500 | 7500 | 24.10 |
| 20 | HFL 2026 | 26 | 26 | 8300 | 10400 | 7000 | 6500 | 28.50 |
| 25 | HFL 2530 | 32 | 30 | 10900 | 14100 | 5500 | 5500 | 66.00 |
| 30 | HFL 3030 | 37 | 30 | 12600 | 17600 | 4500 | 4500 | 90.00 |
| 35 | HFL 3530 | 42 | 30 | 13000 | 19300 | 3900 | 3900 | 121.00 |



Machined-ring needle roller bearings



TECHNICAL SUPPLEMENT

T058 - 059

PRODUCT INFORMATION

P060 - 083



NA 48, NA 49, NA 59

P060 - 067

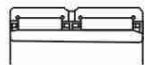

NA 69 ZW

P060 - 067



NA 49..RSR, RNA 49..RSR

P068 - 069



NA 49..2RSR, RNA 49..2RSR

P068 - 069

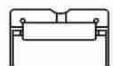

RNA 48, RNA 49, RNA 59, NK

P070 - 077

P070 - 077

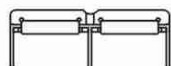

RNA 69 ZW

P078 - 081



NKI

P082 - 083

1. Bearing materials

The available **KSM** Machined Ring Needle Roller Bearings, without an inner ring, include the series NK and RNA (metric series). The dimension series of the series RNA includes the RNA 49, RNA 59, and RNA 69. The bearing series with an inner ring include NKI and NA (metric series). The dimension series of series NA include NA 48, NA 49, NA 59, and NA 69. The boundary dimensions (bore diameter, outside diameter, width, and chamfer dimension) for these dimension series are specified in ISO 15. The third and fourth significant numerals in their bearing numbers represent width number and diameter number, respectively. Particular bearings, whose inscribed enveloping circle diameter is 40 mm or greater, among the RNA 69 (NA 69) bearings have double-row needle rollers, while bearings of other models and dimension series have single-row needle rollers. With bearings whose inscribed enveloping circle diameter (F_{iv}) does not exceed 12 mm, the needle rollers and cage are retained in the outer ring by the side plate: in the case of the inscribed enveloping circle diameter (F_{iv}) exceeding 12 mm, the needle rollers and cage are retained in the outer ring by the rib. The outer rings (other than those of series NK bearings whose inscribed enveloping circle diameter does not exceed 12 mm) have a lubrication hole and oil groove to simplify relubrication of the bearing. The cage used on **KSM** Machined Ring Needle Roller Bearings is usually a machined or pressed-steel type. However, cages of molded polyamide reinforced with glass fiber or carbon fiber (suffix TV) may be used. The T2 cage features a maximum allowable operating temperature of 120°C and maximum allowable continuous operating temperature of 100°C. Series RNA 49 (NA 49) bearings include a sealed type whose outer ring has a synthetic rubber seal on one or both ends (suffix RSR, 2RSR). This variant is pre-filled with lithium soap grease and can operate within a temperature range of -25°C to 100°C.

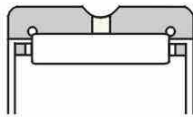

Fig. 1 Series RNA (NK)

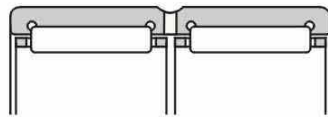

Fig. 2 Series RNA (double row)

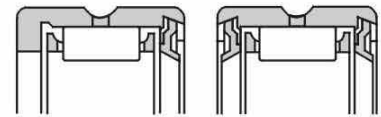

Fig. 3 Series RNA 49..RSR(2RSR)

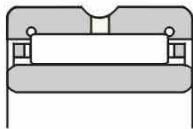

Fig. 4 Series NA

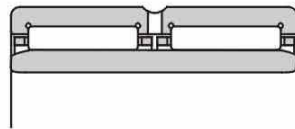

Fig. 5 Series NA (double row)

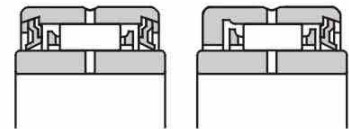

Fig. 6 Series NA 49..RSR (2RSR)

2. Interpreting bearing numbers

The bearing numbers of **KSM** Machined Ring Needle Roller Bearings, series RNA and NA, comprise a series number, dimension series code, bore diameter number, and suffix. Bearing numbers of series NK bearings comprise a series number, dimension code (inscribed enveloping circle diameter/width dimension)

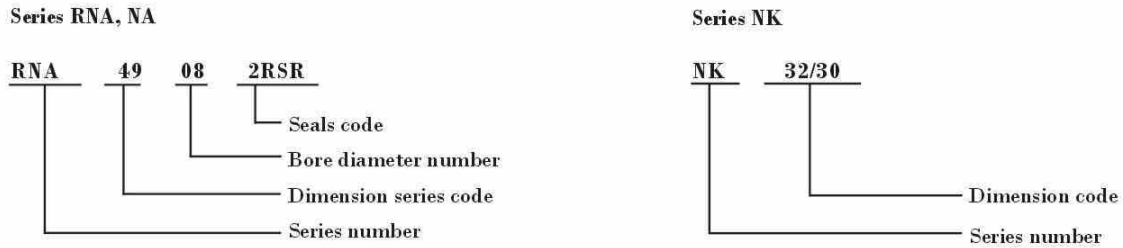

Fig. 7

3. Interpreting clearance and bearing fits

The radial clearances of **KSM** Machined Ring Roller Bearings with an Inner ring are given in "Bearing Internal Clearance". Because the range of non-interchangeable clearance is limited, a bearing delivered adjusted to a non-interchangeable clearance must be mounted as is. The dimensional tolerances (fits) with the shaft and housing bore when installing a bearing with an inner ring vary with the type and magnitude of load, shaft diameter, and housing bore size, and must satisfy the requirements in "Recommended fits". The required form accuracy and surface roughness are specified in "Shaft and housing accuracy". The bearing without an inner ring uses a shaft as a raceway surface. The required tolerances of the shaft diameter (raceway diameter) corresponding with the running clearance are given in Table 1 below. The dimensional tolerance of the housing bore is K7, which is commonly used. For the form accuracy, roughness, and hardness of the shaft as a raceway surface, refer to Table 1 "Accuracy of Raceway surface".

Table 1 Dimensional tolerances of shaft (raceway diameter)

| Enveloping circle dia. | | Tolerance class of shaft | | |
|------------------------|-------|-------------------------------|------------------|-------------------------------|
| F_w | | smaller than normal clearance | normal clearance | greater than normal clearance |
| mm | incl. | | | |
| over | | | | |
| - | 80 | k5 | h5 | f6 |
| 80 | 160 | k5 | g5 | f6 |
| 160 | 180 | k5 | g5 | e6 |
| 180 | 200 | j5 | g5 | e6 |
| 200 | 250 | j5 | f6 | e6 |
| 250 | 315 | h5 | f6 | e6 |
| 315 | 400 | g5 | f6 | d6 |

Machined-ring needle roller bearings with inner ring series NA 49-59-69

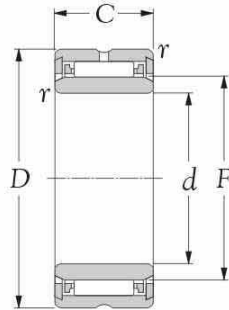

Type NA 49 ($d \leq 9 \text{ mm}$)

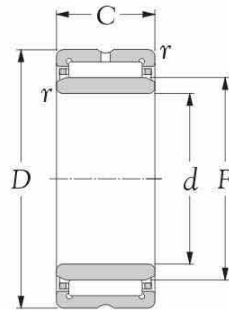

Type NA 49 ($d \geq 10 \text{ mm}$)

Type NA 59

Type NA 69 ($d \leq 30 \text{ mm}$)

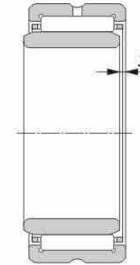

| Inner bore d mm | Bearing number | Principal dimensions | | | | | Basic load ratings | | | |
|-------------------------|----------------|----------------------|-----|------------------------------|-----|-----------|---------------------|-----------------|-----------------------|-----------------|
| | | D | C | $r_s \text{ mm}^{(1)}$ mm | F | $s^{(2)}$ | dynamic C N | static C_o | dynamic C kgf | static C_o |
| 5 | NA 495 | 13 | 10 | 0.15 | 7 | - | 2670 | 2350 | 272 | 239 |
| 6 | NA 496 | 15 | 10 | 0.15 | 8 | - | 3150 | 3000 | 320 | 305 |
| 7 | NA 497 | 17 | 10 | 0.15 | 9 | - | 3600 | 3650 | 365 | 375 |
| 8 | NA 498 | 19 | 11 | 0.15 | 10 | - | 4300 | 3950 | 435 | 405 |
| 9 | NA 499 | 20 | 11 | 0.30 | 12 | - | 4850 | 4900 | 495 | 500 |
| 10 | NA 4900 | 22 | 13 | 0.30 | 14 | 0.5 | 8600 | 9200 | 875 | 935 |
| 12 | NA 4901 | 24 | 13 | 0.30 | 16 | 0.5 | 9550 | 10900 | 975 | 1110 |
| 12 | NA 6901 | 24 | 22 | 0.30 | 16 | 1.0 | 15400 | 20000 | 1570 | 2040 |
| 15 | NA 4902 | 28 | 13 | 0.30 | 20 | 0.5 | 10300 | 12800 | 1050 | 1310 |
| 15 | NA 5902 | 28 | 18 | 0.30 | 20 | 0.5 | 14100 | 19100 | 1440 | 1950 |
| 15 | NA 6902 | 28 | 23 | 0.30 | 20 | 1.0 | 17600 | 25300 | 1790 | 2580 |
| 17 | NA 4903 | 30 | 13 | 0.30 | 22 | 0.5 | 11200 | 14600 | 1140 | 1490 |
| 17 | NA 5903 | 30 | 18 | 0.30 | 22 | 0.5 | 15200 | 21700 | 1550 | 2210 |
| 17 | NA 6903 | 30 | 23 | 0.30 | 22 | 1.0 | 18200 | 27200 | 1850 | 2770 |
| 20 | NA 4904 | 37 | 17 | 0.30 | 25 | 0.8 | 21300 | 25500 | 2170 | 2600 |
| 20 | NA 5904 | 37 | 23 | 0.30 | 25 | 0.8 | 28400 | 37000 | 2900 | 3750 |
| 20 | NA 6904 | 37 | 30 | 0.30 | 25 | 1.0 | 36500 | 50500 | 3700 | 5150 |
| 22 | NA 49/22 | 39 | 17 | 0.30 | 28 | 0.8 | 23200 | 29300 | 2360 | 2990 |
| 22 | NA 59/22 | 39 | 23 | 0.30 | 28 | 0.8 | 26400 | 37500 | 2690 | 3850 |
| 22 | NA 69/22 | 39 | 30 | 0.30 | 28 | 0.5 | 40000 | 58500 | 4050 | 6000 |
| 25 | NA 4905 | 42 | 17 | 0.30 | 30 | 0.8 | 24000 | 31500 | 2450 | 3200 |
| 25 | NA 5905 | 42 | 23 | 0.30 | 30 | 0.8 | 30500 | 43000 | 3150 | 4350 |
| 25 | NA 6905 | 42 | 30 | 0.30 | 30 | 1.0 | 41500 | 63000 | 4200 | 6400 |
| 28 | NA 49/28 | 45 | 17 | 0.30 | 32 | 0.8 | 24800 | 33500 | 2530 | 3400 |
| 28 | NA 59/28 | 45 | 23 | 0.30 | 32 | 0.8 | 32000 | 45500 | 3250 | 4650 |
| 28 | NA 69/28 | 45 | 30 | 0.30 | 32 | 1.0 | 43000 | 67000 | 4350 | 6850 |
| 30 | NA 4906 | 47 | 17 | 0.30 | 35 | 0.8 | 25500 | 35500 | 2600 | 3600 |
| 30 | NA 5906 | 47 | 23 | 0.30 | 35 | 0.8 | 32500 | 48500 | 3350 | 4950 |
| 30 | NA 6906 | 47 | 30 | 0.30 | 35 | 1.0 | 42500 | 67500 | 4300 | 6900 |
| 32 | NA 49/32 | 52 | 20 | 0.60 | 40 | 0.8 | 31500 | 47500 | 3200 | 4850 |
| 32 | NA 59/32 | 52 | 27 | 0.60 | 40 | 0.8 | 38000 | 61000 | 3850 | 6250 |

Note: 1) These values are the allowable minimum dimensions of the chamfer dimension r
2) These values are the possible axial displacement of the inner ring against outer ring

Machined-ring needle roller bearings with inner ring series NA 49-59-69

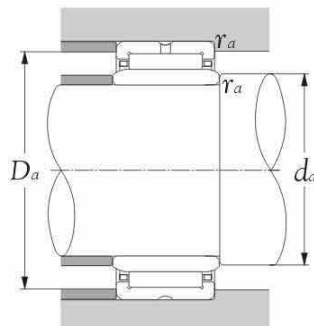
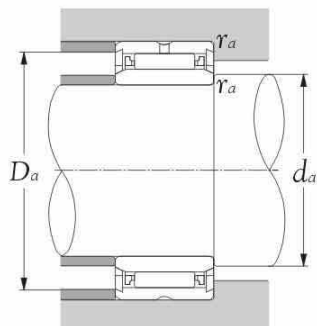

| Max runout speed | | Abutment dimensions | | | Weight |
|------------------|-------|---------------------|--------------|--------------|--------|
| grease | oil | d_a mm | D_a max | r_a max | kg. |
| r/min | | | | | |
| 23000 | 34000 | 6.2 | 8.5 | 0.15 | 0.007 |
| 21000 | 32000 | 8.0 | 9.5 | 0.15 | 0.009 |
| 20000 | 30000 | 9.0 | 10.5 | 0.15 | 0.010 |
| 19000 | 28000 | 10.0 | 12.0 | 0.15 | 0.016 |
| 17000 | 26000 | 11.0 | 14.0 | 0.30 | 0.017 |
| 16000 | 24000 | 12.0 | 20.0 | 0.30 | 0.024 |
| 15000 | 23000 | 14.0 | 22.0 | 0.30 | 0.026 |
| 15000 | 23000 | 14.0 | 22.0 | 0.30 | 0.046 |
| 13000 | 20000 | 17.0 | 26.0 | 0.30 | 0.036 |
| 13000 | 20000 | 17.0 | 26.0 | 0.30 | 0.052 |
| 13000 | 20000 | 17.0 | 26.0 | 0.30 | 0.064 |
| 12000 | 18000 | 19.0 | 28.0 | 0.30 | 0.056 |
| 12000 | 18000 | 19.0 | 28.0 | 0.30 | 0.037 |
| 12000 | 18000 | 19.0 | 28.0 | 0.30 | 0.069 |
| 11000 | 16000 | 22.0 | 35.0 | 0.30 | 0.074 |
| 11000 | 16000 | 22.0 | 35.0 | 0.30 | 0.115 |
| 11000 | 16000 | 22.0 | 35.0 | 0.30 | 0.141 |
| 9500 | 14000 | 24.0 | 37.0 | 0.30 | 0.080 |
| 9500 | 14000 | 24.0 | 37.0 | 0.30 | 0.134 |
| 9500 | 14000 | 24.0 | 37.0 | 0.30 | 0.154 |
| 8500 | 13000 | 27.0 | 40.0 | 0.30 | 0.088 |
| 8500 | 13000 | 27.0 | 40.0 | 0.30 | 0.139 |
| 8500 | 13000 | 27.0 | 40.0 | 0.30 | 0.162 |
| 8500 | 13000 | 30.0 | 43.0 | 0.30 | 0.098 |
| 8500 | 13000 | 30.0 | 43.0 | 0.30 | 0.142 |
| 8500 | 13000 | 30.0 | 43.0 | 0.30 | 0.179 |
| 7500 | 11000 | 32.0 | 45.0 | 0.30 | 0.101 |
| 7500 | 11000 | 32.0 | 45.0 | 0.30 | 0.152 |
| 7500 | 11000 | 32.0 | 45.0 | 0.30 | 0.185 |
| 6500 | 10000 | 36.0 | 48.0 | 0.60 | 0.157 |
| 6500 | 10000 | 36.0 | 48.0 | 0.60 | 0.241 |



Machined-ring needle roller bearings with inner ring series NA 49-59-69

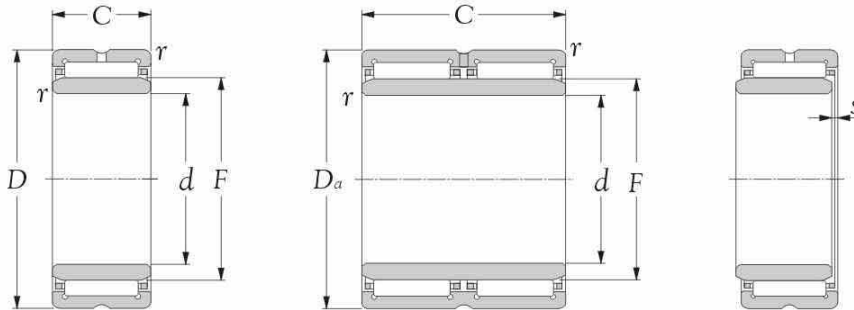

Type NA 49 ($d \geq 10 \text{ mm}$)
Type NA 59

Type NA 69 ZW ($d \geq 32 \text{ mm}$)

| Inner bore d mm | Bearing number | Principal dimensions | | | | | Basic load ratings | | | |
|-------------------------|----------------|----------------------|-----|-----------------------------|-----|----------|---------------------|-----------------|-----------------------|-----------------|
| | | D | C | $r_s \text{ mm}^{1)}$ mm | F | $s^{2)}$ | dynamic C N | static C_o | dynamic C kgf | static C_o |
| 32 | NA 69/32 ZW | 52 | 36 | 0.6 | 40 | 0.5 | 47500 | 82000 | 4850 | 4350 |
| 35 | NA 4907 | 55 | 20 | 0.6 | 42 | 0.8 | 32000 | 50000 | 3300 | 5100 |
| 35 | NA 5907 | 55 | 27 | 0.6 | 42 | 0.8 | 39000 | 64500 | 3950 | 6550 |
| 35 | NA 6907 ZW | 55 | 36 | 0.6 | 42 | 0.5 | 49000 | 86500 | 5000 | 8800 |
| 40 | NA 4908 | 62 | 22 | 0.6 | 48 | 1.0 | 43500 | 66500 | 4450 | 6800 |
| 40 | NA 5908 | 62 | 30 | 0.6 | 48 | 1.0 | 53000 | 92500 | 5450 | 9450 |
| 40 | NA 6908 ZW | 62 | 40 | 0.6 | 48 | 0.5 | 67000 | 116000 | 6850 | 11800 |
| 45 | NA 4909 | 68 | 22 | 0.6 | 52 | 1.0 | 46000 | 73000 | 4700 | 7450 |
| 45 | NA 5909 | 68 | 30 | 0.6 | 52 | 1.0 | 56000 | 101000 | 5700 | 10300 |
| 45 | NA 6909 ZW | 68 | 40 | 0.6 | 52 | 0.5 | 70500 | 127000 | 7200 | 13000 |
| 50 | NA 4910 | 72 | 22 | 0.6 | 58 | 1.0 | 48000 | 80000 | 4900 | 8150 |
| 50 | NA 5910 | 72 | 30 | 0.6 | 58 | 1.0 | 58000 | 110000 | 5950 | 11200 |
| 50 | NA 6910 ZW | 72 | 40 | 0.6 | 58 | 0.5 | 74000 | 139000 | 7500 | 14200 |
| 55 | NA 4911 | 80 | 25 | 1.0 | 63 | 1.5 | 58500 | 99500 | 6000 | 10100 |
| 55 | NA 5911 | 80 | 34 | 1.0 | 63 | 1.5 | 76500 | 140000 | 7800 | 14300 |
| 55 | NA 6911 ZW | 80 | 45 | 1.0 | 63 | 1.5 | 94000 | 183000 | 9600 | 18600 |
| 60 | NA 4912 | 85 | 25 | 1.0 | 68 | 1.5 | 61500 | 108000 | 6250 | 11000 |
| 60 | NA 5912 | 85 | 34 | 1.0 | 68 | 1.5 | 80500 | 153000 | 8200 | 15600 |
| 60 | NA 6912 ZW | 85 | 45 | 1.0 | 68 | 1.5 | 95500 | 191000 | 9750 | 19400 |
| 65 | NA 4913 | 90 | 25 | 1.0 | 72 | 1.5 | 62500 | 112000 | 6350 | 11400 |
| 65 | NA 5913 | 90 | 34 | 1.0 | 72 | 1.5 | 84000 | 165000 | 8600 | 16800 |
| 65 | NA 6913 ZW | 90 | 45 | 1.0 | 72 | 1.5 | 97000 | 198000 | 9900 | 20200 |
| 70 | NA 4914 | 100 | 30 | 1.0 | 80 | 1.5 | 85500 | 156000 | 8750 | 15900 |
| 70 | NA 5914 | 100 | 40 | 1.0 | 80 | 1.5 | 103000 | 187000 | 10500 | 19100 |
| 70 | NA 6914 ZW | 100 | 54 | 1.0 | 80 | 1.0 | 130000 | 267000 | 13300 | 27200 |
| 75 | NA 4915 | 105 | 30 | 1.0 | 85 | 1.5 | 87000 | 162000 | 8900 | 16500 |
| 75 | NA 5915 | 105 | 40 | 1.0 | 85 | 1.5 | 109000 | 205000 | 11100 | 20900 |
| 75 | NA 6915 ZW | 105 | 54 | 1.0 | 85 | 1.0 | 132000 | 277000 | 13500 | 28300 |
| 80 | NA 4916 | 110 | 30 | 1.0 | 90 | 1.5 | 90500 | 174000 | 9250 | 17700 |
| 80 | NA 5916 | 110 | 40 | 1.0 | 90 | 1.5 | 115000 | 223000 | 11700 | 22700 |
| 80 | NA 6916 ZW | 110 | 54 | 1.0 | 90 | 1.5 | 137000 | 298000 | 14000 | 30500 |

Note: 1) These values are the allowable minimum dimensions of the chamfer dimension r
2) These values are the possible axial displacement of the inner ring against outer ring

Machined-ring needle roller bearings with inner ring series NA 49-59-69

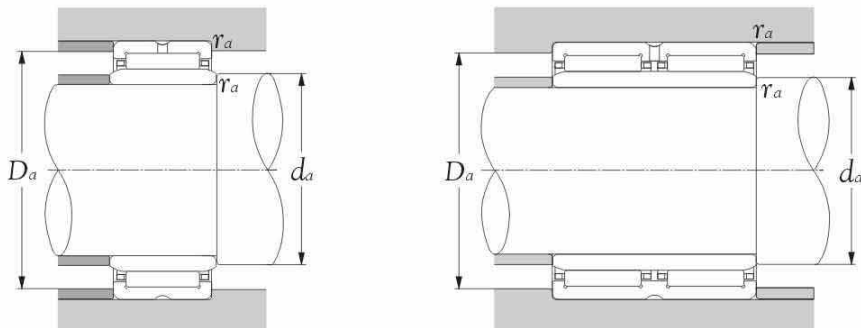

| Max runout speed | | Abutment dimensions | | | Weight |
|------------------|-------|---------------------|--------------|--------------|--------|
| grease | oil | d_a mm | D_a max | r_a max | kg(s). |
| r/min | | | | | |
| 6500 | 10000 | 36 | 48 | 0.6 | 0.286 |
| 6500 | 9500 | 39 | 51 | 0.6 | 0.171 |
| 6500 | 9500 | 39 | 51 | 0.6 | 0.256 |
| 6500 | 9500 | 39 | 51 | 0.6 | 0.310 |
| 5500 | 8500 | 44 | 58 | 0.6 | 0.232 |
| 5500 | 8500 | 44 | 58 | 0.6 | 0.348 |
| 5500 | 8500 | 44 | 58 | 0.6 | 0.426 |
| 5000 | 7500 | 49 | 64 | 0.6 | 0.270 |
| 5000 | 7500 | 49 | 64 | 0.6 | 0.396 |
| 5000 | 7500 | 49 | 64 | 0.6 | 0.437 |
| 4700 | 7000 | 54 | 68 | 0.6 | 0.276 |
| 4700 | 7000 | 54 | 68 | 0.6 | 0.498 |
| 4700 | 7000 | 54 | 68 | 0.6 | 0.529 |
| 4300 | 6500 | 60 | 75 | 1.0 | 0.396 |
| 4300 | 6500 | 60 | 75 | 1.0 | 0.559 |
| 4300 | 6500 | 60 | 75 | 1.0 | 0.726 |
| 4000 | 6000 | 65 | 80 | 1.0 | 0.427 |
| 4000 | 6000 | 65 | 80 | 1.0 | 0.614 |
| 4000 | 6000 | 65 | 80 | 1.0 | 0.758 |
| 3700 | 5500 | 70 | 85 | 1.0 | 0.454 |
| 3700 | 5500 | 70 | 85 | 1.0 | 0.655 |
| 3700 | 5500 | 70 | 85 | 1.0 | 0.779 |
| 3300 | 5000 | 75 | 95 | 1.0 | 0.727 |
| 3300 | 5000 | 75 | 95 | 1.0 | 1.060 |
| 3300 | 5000 | 75 | 95 | 1.0 | 1.340 |
| 3100 | 4700 | 80 | 100 | 1.0 | 0.776 |
| 3100 | 4700 | 80 | 100 | 1.0 | 1.130 |
| 3100 | 4700 | 80 | 100 | 1.0 | 1.450 |
| 2900 | 4400 | 85 | 105 | 1.0 | 0.820 |
| 2900 | 4400 | 85 | 105 | 1.0 | 1.150 |
| 2900 | 4400 | 85 | 105 | 1.0 | 1.530 |

Machined-ring needle roller bearings with inner ring series NA 48-49-59-69

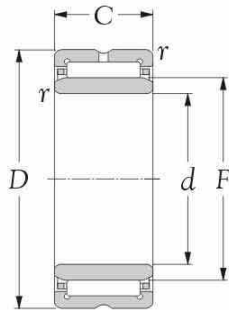

Type NA 48
Type NA 49 ($d \geq 10$ mm)
Type NA 59

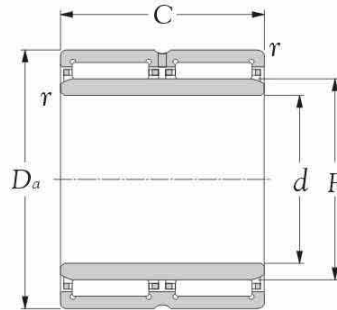

Type NA 69 ZW ($d \geq 32$ mm)

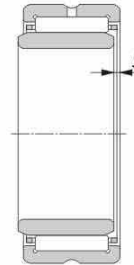

| Inner bore d mm | Bearing number | Principal dimensions | | | | | Basic load ratings | | | |
|-------------------------|----------------|----------------------|-----|------------------------------|-----|-------------------|---------------------|-----------------|-----------------------|-----------------|
| | | D | C | r_s mm ¹⁾ mm | F | s ²⁾ | dynamic C N | static C_o | dynamic C kgf | static C_o |
| 85 | NA 4917 | 120 | 35 | 1.1 | 100 | 1.0 | 112000 | 237000 | 11500 | 24200 |
| 85 | NA 5917 | 120 | 46 | 1.1 | 100 | 1.5 | 137000 | 290000 | 14000 | 29600 |
| 85 | NA 6917 ZW | 120 | 63 | 1.1 | 100 | 1.0 | 169000 | 400000 | 17300 | 41000 |
| 90 | NA 4918 | 125 | 35 | 1.1 | 105 | 1.0 | 116000 | 252000 | 11900 | 25700 |
| 90 | NA 5918 | 125 | 46 | 1.1 | 105 | 1.0 | 143000 | 310000 | 14600 | 32000 |
| 90 | NA 6918 ZW | 125 | 63 | 1.1 | 105 | 1.0 | 175000 | 425000 | 17900 | 43500 |
| 95 | NA 4919 | 130 | 35 | 1.1 | 110 | 1.0 | 118000 | 260000 | 12000 | 26500 |
| 95 | NA 5919 | 130 | 46 | 1.1 | 110 | 1.0 | 149000 | 335000 | 15200 | 34000 |
| 95 | NA 6919 ZW | 130 | 63 | 1.1 | 110 | 1.0 | 177000 | 440000 | 18100 | 45000 |
| 100 | NA 4920 | 140 | 40 | 1.1 | 115 | 2.0 | 127000 | 260000 | 12900 | 26500 |
| 100 | NA 5920 | 140 | 54 | 1.1 | 115 | 2.0 | 182000 | 395000 | 18600 | 40500 |
| 110 | NA 4822 | 140 | 30 | 1.0 | 120 | 0.8 | 93500 | 210000 | 9550 | 21400 |
| 110 | NA 4922 | 150 | 40 | 1.1 | 125 | 2.0 | 131000 | 279000 | 13300 | 28400 |
| 110 | NA 5922 | 150 | 54 | 1.1 | 125 | 2.0 | 193000 | 440000 | 19700 | 45000 |
| 120 | NA 4824 | 150 | 30 | 1.0 | 130 | 0.8 | 99500 | 233000 | 10100 | 23800 |
| 120 | NA 4924 | 165 | 45 | 1.1 | 135 | 2.0 | 180000 | 380000 | 18300 | 38500 |
| 120 | NA 5924 | 165 | 60 | 1.1 | 135 | 2.0 | 245000 | 525000 | 25000 | 53500 |
| 130 | NA 4826 | 165 | 35 | 1.1 | 145 | 1.0 | 118000 | 305000 | 12100 | 31000 |
| 130 | NA 4926 | 180 | 50 | 1.5 | 150 | 1.5 | 202000 | 455000 | 20600 | 46500 |
| 130 | NA 5926 | 180 | 67 | 1.5 | 150 | 1.5 | 294000 | 685000 | 30000 | 70000 |
| 140 | NA 4828 | 175 | 35 | 1.1 | 155 | 1.0 | 121000 | 315000 | 12300 | 32500 |
| 140 | NA 4928 | 190 | 50 | 1.5 | 160 | 1.5 | 209000 | 485000 | 21300 | 49500 |
| 140 | NA 5928 | 190 | 67 | 1.5 | 160 | 1.5 | 310000 | 755000 | 31500 | 77000 |
| 150 | NA 4830 | 190 | 40 | 1.1 | 165 | 1.5 | 152000 | 390000 | 15500 | 40000 |
| 150 | NA 4930 | 210 | 60 | 2.0 | 170 | 1.5 | 261000 | 610000 | 26600 | 62500 |
| 160 | NA 4832 | 200 | 40 | 1.1 | 175 | 1.5 | 160000 | 425000 | 16300 | 43500 |
| 160 | NA 4932 | 220 | 60 | 2.0 | 180 | 1.5 | 270000 | 650000 | 27600 | 66500 |
| 170 | NA 4834 | 215 | 45 | 1.1 | 185 | 1.5 | 185000 | 495000 | 18800 | 50500 |
| 170 | NA 4934 | 230 | 60 | 2.0 | 190 | 1.5 | 279000 | 690000 | 28500 | 70500 |
| 180 | NA 4836 | 225 | 45 | 1.1 | 195 | 1.5 | 195000 | 540000 | 19800 | 55000 |
| 180 | NA 4936 | 250 | 69 | 2.0 | 205 | 1.5 | 375000 | 890000 | 38500 | 90500 |

Note: 1) These values are the allowable minimum dimensions of the chamfer dimension r

2) These values are the possible axial displacement of the inner ring against outer ring

Machined-ring needle roller bearings with inner ring series NA 48-49-59-69

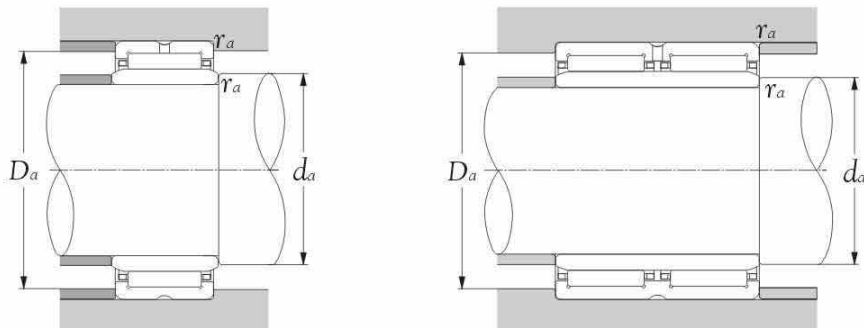

| Max runout speed | | Abutment dimensions | | | Weight |
|------------------|------|---------------------|--------------|--------------|--------|
| grease | oil | d_a mm | D_a max | r_a max | kgs. |
| r/min | | | | | |
| 2700 | 4000 | 91.5 | 113.5 | 1.0 | 1.24 |
| 2700 | 4000 | 91.5 | 113.5 | 1.0 | 1.76 |
| 2700 | 4000 | 91.5 | 113.5 | 1.0 | 2.25 |
| 2500 | 3800 | 96.5 | 118.5 | 1.0 | 1.31 |
| 2500 | 3800 | 96.5 | 118.5 | 1.0 | 1.84 |
| 2500 | 3800 | 96.5 | 118.5 | 1.0 | 2.44 |
| 2400 | 3600 | 101.5 | 123.5 | 1.0 | 1.36 |
| 2400 | 3600 | 101.5 | 123.5 | 1.0 | 1.98 |
| 2400 | 3600 | 101.5 | 123.5 | 1.0 | 2.63 |
| 2300 | 3500 | 106.5 | 133.5 | 1.0 | 1.93 |
| 2300 | 3500 | 106.5 | 133.5 | 1.0 | 2.85 |
| 2200 | 3300 | 115.0 | 135.0 | 1.0 | 1.11 |
| 2100 | 3200 | 116.5 | 143.5 | 1.0 | 2.08 |
| 2100 | 3200 | 116.5 | 143.5 | 1.0 | 2.98 |
| 2100 | 3100 | 125.0 | 145.0 | 1.0 | 1.17 |
| 2000 | 3000 | 126.5 | 158.5 | 1.0 | 2.84 |
| 2000 | 3000 | 126.5 | 158.5 | 1.0 | 3.92 |
| 1900 | 2800 | 136.5 | 158.5 | 1.0 | 1.60 |
| 1800 | 2700 | 138.0 | 172.0 | 1.5 | 3.90 |
| 1800 | 2700 | 138.0 | 172.0 | 1.5 | 5.60 |
| 1700 | 2600 | 146.5 | 168.5 | 1.0 | 1.32 |
| 1700 | 2500 | 148.0 | 182.0 | 1.5 | 4.05 |
| 1700 | 2500 | 148.0 | 182.0 | 1.5 | 6.18 |
| 1600 | 2400 | 156.5 | 183.5 | 1.0 | 2.72 |
| 1600 | 2400 | 159.0 | 201.0 | 2.0 | 5.33 |
| 1500 | 2300 | 166.5 | 193.5 | 1.0 | 2.90 |
| 1500 | 2200 | 169.0 | 211.0 | 2.0 | 5.60 |
| 1500 | 2200 | 176.5 | 208.5 | 1.0 | 3.99 |
| 1400 | 2100 | 179.0 | 221.0 | 2.0 | 5.87 |
| 1400 | 2100 | 186.5 | 218.5 | 1.0 | 4.19 |
| 1300 | 2000 | 189.0 | 241.0 | 2.0 | 8.58 |



Machined-ring needle roller bearings with inner ring series NA 48-49



Type NA 48

Type NA 49 ($d \geq 10$ mm)

| Inner bore d mm | Bearing number | Principal dimensions | | | | | Basic load ratings | | | |
|-------------------------|----------------|----------------------|-----|------------------------------|-----|-------------------|---------------------|-----------------|-----------------------|-----------------|
| | | D | C | r_s mm ¹⁾ mm | F | s ²⁾ | dynamic C N | static C_o | dynamic C kgf | static C_o |
| 190 | NA 4838 | 240 | 50 | 1.5 | 210 | 1.5 | 227000 | 680000 | 23200 | 69000 |
| 190 | NA 4938 | 260 | 69 | 2.0 | 215 | 1.5 | 390000 | 945000 | 40000 | 96500 |
| 200 | NA 4840 | 250 | 50 | 1.5 | 220 | 1.5 | 231000 | 705000 | 23600 | 71500 |
| 200 | NA 4940 | 280 | 80 | 2.1 | 225 | 1.5 | 505000 | 1180000 | 51500 | 120000 |
| 220 | NA 4844 | 270 | 50 | 1.5 | 240 | 1.5 | 244000 | 780000 | 24900 | 79500 |
| 220 | NA 4944 | 300 | 80 | 2.1 | 245 | 1.5 | 525000 | 1270000 | 53500 | 129000 |
| 240 | NA 4848 | 300 | 60 | 2.0 | 265 | 2.0 | 360000 | 1080000 | 37000 | 110000 |
| 240 | NA 4948 | 320 | 80 | 2.1 | 265 | 2.0 | 540000 | 1350000 | 55000 | 138000 |
| 260 | NA 4852 | 320 | 60 | 2.0 | 285 | 2.0 | 375000 | 1160000 | 38000 | 119000 |
| 260 | NA 4952 | 360 | 100 | 2.1 | 290 | 2.0 | 805000 | 1900000 | 82000 | 193000 |
| 280 | NA 4856 | 350 | 69 | 2.0 | 305 | 2.5 | 455000 | 1300000 | 46500 | 133000 |
| 280 | NA 4956 | 380 | 100 | 2.1 | 310 | 2.5 | 835000 | 2030000 | 85000 | 207000 |
| 300 | NA 4860 | 380 | 80 | 2.1 | 330 | 2.0 | 625000 | 1770000 | 64000 | 180000 |
| 300 | NA 4960 | 420 | 118 | 3.0 | 340 | 2.0 | 1080000 | 2640000 | 110000 | 269000 |
| 320 | NA 4864 | 400 | 80 | 2.1 | 350 | 2.0 | 640000 | 1850000 | 65500 | 189000 |
| 320 | NA 4964 | 440 | 118 | 3.0 | 360 | 2.0 | 1120000 | 2820000 | 114000 | 288000 |
| 340 | NA 4868 | 420 | 80 | 2.1 | 370 | 2.0 | 655000 | 1940000 | 66500 | 197000 |
| 340 | NA 4968 | 460 | 118 | 3.0 | 380 | 2.0 | 1160000 | 3000000 | 118000 | 305000 |
| 360 | NA 4872 | 440 | 80 | 2.1 | 390 | 2.0 | 665000 | 2020000 | 68000 | 206000 |
| 360 | NA 4972 | 480 | 118 | 3.0 | 400 | 2.0 | 1200000 | 3200000 | 122000 | 325000 |
| 380 | NA 4876 | 480 | 100 | 2.1 | 415 | 2.0 | 1000000 | 2840000 | 102000 | 289000 |
| 380 | NA 4976 | 520 | 140 | 4.0 | 430 | 2.0 | 1400000 | 3750000 | 143000 | 385000 |
| 400 | NA 4980 | 540 | 140 | 4.0 | 450 | 2.5 | 1450000 | 4000000 | 148000 | 410000 |
| 420 | NA 4984 | 560 | 140 | 4.0 | 470 | 2.5 | 1500000 | 4250000 | 153000 | 430000 |
| 440 | NA 4988 | 600 | 160 | 4.0 | 490 | 2.5 | 1750000 | 4600000 | 179000 | 470000 |

Note: 1) These values are the allowable minimum dimensions of the chamfer dimension r
 2) These values are the possible axial displacement of the inner ring against outer ring

Machined-ring needle roller bearings with inner ring series NA 48-49-59-69

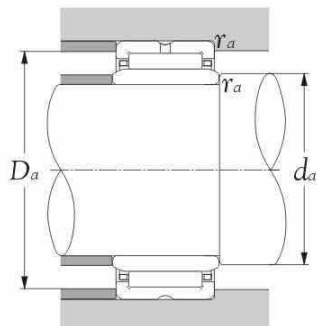

| Max runout speed | | Abutment dimensions | | | Weight |
|------------------|------|---------------------|--------------|--------------|--------|
| grease | oil | d_a mm | D_a max | r_a max | kgs. |
| r/min | | | | | |
| 1300 | 1900 | 198 | 232 | 1.5 | 5.62 |
| 1300 | 1900 | 199 | 251 | 2.0 | 8.68 |
| 1200 | 1800 | 208 | 242 | 1.5 | 5.84 |
| 1200 | 1800 | 211 | 269 | 2.0 | 12.20 |
| 1100 | 1700 | 228 | 262 | 1.5 | 6.37 |
| 1100 | 1600 | 231 | 289 | 2.0 | 13.50 |
| 1000 | 1500 | 249 | 291 | 2.0 | 10.00 |
| 1000 | 1500 | 251 | 309 | 2.0 | 14.70 |
| 950 | 1400 | 269 | 311 | 2.0 | 10.80 |
| 950 | 1400 | 271 | 349 | 2.0 | 25.90 |
| 850 | 1300 | 289 | 341 | 2.0 | 15.50 |
| 850 | 1300 | 291 | 369 | 2.0 | 27.50 |
| 800 | 1200 | 311 | 369 | 2.0 | 22.00 |
| 800 | 1200 | 313 | 407 | 2.5 | 42.50 |
| 750 | 1100 | 331 | 389 | 2.0 | 23.20 |
| 750 | 1100 | 333 | 427 | 2.5 | 45.20 |
| 750 | 1100 | 351 | 409 | 2.0 | 24.10 |
| 750 | 1100 | 353 | 447 | 2.5 | 47.30 |
| 650 | 1000 | 371 | 429 | 2.0 | 25.70 |
| 650 | 1000 | 373 | 467 | 2.5 | 49.00 |
| 650 | 950 | 391 | 469 | 2.0 | 44.50 |
| 650 | 950 | 396 | 504 | 3.0 | 73.60 |
| 600 | 900 | 416 | 524 | 3.0 | 76.60 |
| 550 | 850 | 436 | 544 | 3.0 | 89.80 |
| 550 | 800 | 456 | 584 | 3.0 | 123.00 |



Machined-ring needle roller bearings with inner ring sealed type series NA 49..RSR, 2RSR

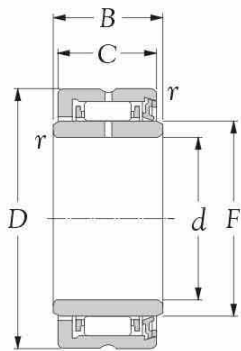

Type NA 49..RSR
(With single seal)

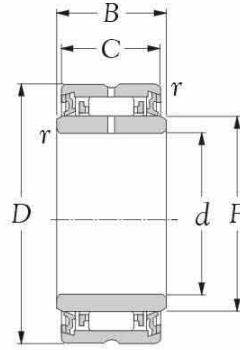

Type NA 49..2RSR
(With double seals)

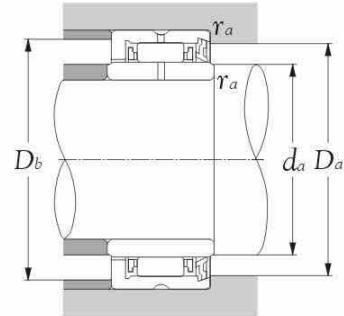

| Inner bore <i>d</i> mm | Bearing number | | Principal dimensions | | | | | Basic load ratings | | | | Limiting speeds rpm | Abutment dimensions | | | | Weight kg. |
|------------------------------|----------------|--------------|----------------------|----------|----------|----------|------------------------|--------------------|-----------------------|----------|-----------------------|------------------------|-------------------------|-------------------------|-----------------------|----------------------|---------------|
| | | | <i>D</i> | <i>B</i> | <i>C</i> | <i>F</i> | $r_s \text{ min}^{-1}$ | <i>C</i> | <i>C</i> ₀ | <i>C</i> | <i>C</i> ₀ | | <i>d</i> _{max} | <i>D</i> _{max} | <i>D</i> _b | $r_{as} \text{ max}$ | |
| 10 | NA 4900 RSR | NA 4900 2RSR | 22 | 14 | 13 | 14 | 0.3 | 7200 | 8500 | 735 | 865 | 10000 | 12 | 16 | 20 | 0.3 | 0.025 |
| 12 | NA 4901 RSR | NA 4901 2RSR | 24 | 14 | 13 | 16 | 0.3 | 7750 | 9700 | 795 | 990 | 10000 | 14 | 18 | 22 | 0.3 | 0.028 |
| 15 | NA 4902 RSR | NA 4902 2RSR | 28 | 14 | 13 | 20 | 0.3 | 8300 | 11200 | 845 | 1150 | 10000 | 17 | 22 | 26 | 0.3 | 0.036 |
| 17 | NA 4903 RSR | NA 4903 2RSR | 30 | 14 | 13 | 22 | 0.3 | 8500 | 11900 | 865 | 1220 | 9000 | 19 | 24 | 28 | 0.3 | 0.039 |
| 20 | NA 4904 RSR | NA 4904 2RSR | 37 | 18 | 17 | 25 | 0.3 | 15200 | 19900 | 1550 | 2030 | 8000 | 22 | 28 | 35 | 0.3 | 0.080 |
| 25 | NA 4905 RSR | NA 4905 2RSR | 42 | 18 | 17 | 30 | 0.3 | 16000 | 22600 | 1640 | 2300 | 6500 | 27 | 33 | 40 | 0.3 | 0.093 |
| 30 | NA 4906 RSR | NA 4906 2RSR | 47 | 18 | 17 | 35 | 0.3 | 18000 | 27400 | 1830 | 2800 | 5500 | 32 | 38 | 45 | 0.3 | 0.107 |
| 35 | NA 4907 RSR | NA 4907 2RSR | 55 | 21 | 20 | 42 | 0.6 | 22700 | 39500 | 2320 | 4000 | 4800 | 39 | 45 | 51 | 0.6 | 0.175 |
| 40 | NA 4908 RSR | NA 4908 2RSR | 62 | 23 | 22 | 48 | 0.6 | 27800 | 53500 | 2830 | 5450 | 4200 | 44 | 51 | 58 | 0.6 | 0.252 |
| 45 | NA 4909 RSR | NA 4909 2RSR | 68 | 23 | 22 | 52 | 0.6 | 28600 | 57000 | 2920 | 5800 | 3800 | 49 | 55 | 64 | 0.6 | 0.290 |
| 50 | NA 4910 RSR | NA 4910 2RSR | 72 | 23 | 22 | 58 | 0.6 | 30500 | 64000 | 3100 | 6500 | 3400 | 54 | 61 | 68 | 0.6 | 0.295 |

Note: 1) These values are the allowable minimum dimensions of the chamfer dimension *r*

Machined-ring needle roller bearings without inner ring sealed type series RNA 49..RSR, 2RSR

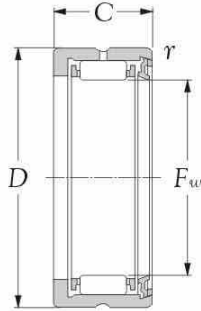

Type RNA 49..RSR
(With single seal)

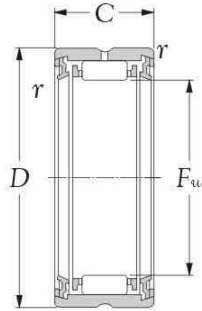

Type RNA 49..2RSR
(With double seals)

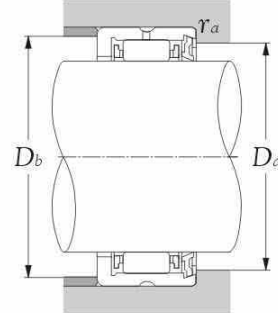

| Inner bore F_w mm | Bearing number | | Principal dimensions | | | Basic load ratings | | | | Limiting speeds rpm | Abutment dimensions | | | Weight kg. |
|---|----------------|---------------|----------------------|-----|------------------------|--------------------|------------|---------|--------------|------------------------|---------------------|--------------|-----------------|---------------|
| | | | D | C | r_s mm ¹⁾ | dynamic | static | dynamic | static | | D_a max | D_b max | r_{as} max | |
| | | | mm | | | C | C_o N | C | C_o kgf | | | | | |
| 14 ^{+0.007} / _{+0.016} | RNA 4900 RSR | RNA 4900 2RSR | 22 | 13 | 0.3 | 7200 | 8500 | 735 | 865 | 10000 | 16 | 20 | 0.3 | 0.016 |
| 16 ^{+0.007} / _{+0.016} | RNA 4901 RSR | RNA 4901 2RSR | 24 | 13 | 0.3 | 7750 | 9700 | 795 | 990 | 10000 | 18 | 22 | 0.3 | 0.018 |
| 20 ^{+0.038} / _{+0.020} | RNA 4902 RSR | RNA 4902 2RSR | 28 | 13 | 0.3 | 8300 | 11200 | 845 | 1150 | 10000 | 22 | 26 | 0.3 | 0.022 |
| 22 ^{+0.038} / _{+0.020} | RNA 4903 RSR | RNA 4903 2RSR | 30 | 13 | 0.3 | 8500 | 11900 | 865 | 1220 | 9000 | 24 | 28 | 0.3 | 0.022 |
| 25 ^{+0.038} / _{+0.020} | RNA 4904 RSR | RNA 4904 2RSR | 37 | 17 | 0.3 | 15200 | 19900 | 1550 | 2030 | 8000 | 28 | 35 | 0.3 | 0.055 |
| 30 ^{+0.038} / _{+0.020} | RNA 4905 RSR | RNA 4905 2RSR | 42 | 17 | 0.3 | 16000 | 22600 | 1640 | 2300 | 6500 | 33 | 40 | 0.3 | 0.063 |
| 35 ^{+0.041} / _{+0.025} | RNA 4906 RSR | RNA 4906 2RSR | 47 | 17 | 0.3 | 18000 | 27400 | 1830 | 2800 | 5500 | 38 | 45 | 0.3 | 0.072 |
| 42 ^{+0.041} / _{+0.025} | RNA 4907 RSR | RNA 4907 2RSR | 55 | 20 | 0.6 | 22700 | 39500 | 2320 | 4000 | 4800 | 45 | 51 | 0.6 | 0.113 |
| 48 ^{+0.041} / _{+0.025} | RNA 4908 RSR | RNA 4908 2RSR | 62 | 22 | 0.6 | 27800 | 53500 | 2830 | 5450 | 4200 | 51 | 58 | 0.6 | 0.154 |
| 52 ^{+0.049} / _{+0.030} | RNA 4909 RSR | RNA 4909 2RSR | 68 | 22 | 0.6 | 28600 | 57000 | 2920 | 5800 | 3800 | 55 | 64 | 0.6 | 0.157 |
| 58 ^{+0.049} / _{+0.030} | RNA 4910 RSR | RNA 4910 2RSR | 72 | 22 | 0.6 | 30500 | 64000 | 3100 | 6500 | 3400 | 61 | 68 | 0.6 | 0.160 |

Note: 1) These values are the allowable minimum dimensions of the chamfer dimension r

Machined-ring needle roller bearings without inner ring series RNA 49-59-69

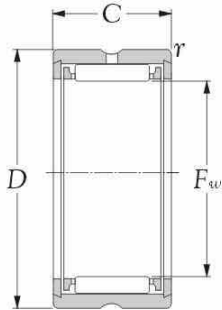

Type RNA 49 ($F_w \leq 12 \text{ mm}$)

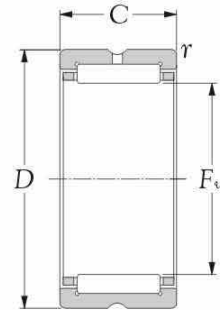

Type RNA 49 ($F_w \geq 14 \text{ mm}$)

Type RNA 59

Type RNA 69 ($F_w \leq 35 \text{ mm}$)

| Inner bore F_w mm | Bearing number | Principal dimensions | | | Basic load ratings | | | |
|--|----------------|----------------------|-----------|--------------------------------|---------------------|-----------------|-----------------------|-----------------|
| | | D | C mm | $r_s \text{ mm}^{\frac{1}{3}}$ | dynamic C N | static C_o | dynamic C kgf | static C_o |
| 7 ^{+0.022} / _{+0.013} | RNA 495 | 13 | 10 | 0.15 | 2670 | 2350 | 272 | 239 |
| 8 ^{+0.022} / _{+0.013} | RNA 496 | 15 | 10 | 0.15 | 3150 | 3000 | 320 | 305 |
| 9 ^{+0.022} / _{+0.013} | RNA 497 | 17 | 10 | 0.15 | 3600 | 3650 | 365 | 375 |
| 10 ^{+0.022} / _{+0.013} | RNA 498 | 19 | 11 | 0.15 | 4300 | 3950 | 435 | 405 |
| 12 ^{+0.027} / _{+0.016} | RNA 499 | 20 | 11 | 0.30 | 4850 | 4900 | 495 | 500 |
| 14 ^{+0.027} / _{+0.016} | RNA 4900 | 22 | 13 | 0.30 | 8600 | 9200 | 875 | 935 |
| 16 ^{+0.027} / _{+0.016} | RNA 4901 | 24 | 13 | 0.30 | 9550 | 10900 | 975 | 1110 |
| 16 ^{+0.027} / _{+0.016} | RNA 6901 | 24 | 22 | 0.30 | 15400 | 20000 | 1570 | 2040 |
| 20 ^{+0.038} / _{+0.020} | RNA 4902 | 28 | 13 | 0.30 | 10300 | 12800 | 1050 | 1310 |
| 20 ^{+0.038} / _{+0.020} | RNA 5902 | 28 | 18 | 0.30 | 14100 | 19100 | 1440 | 1950 |
| 20 ^{+0.038} / _{+0.020} | RNA 6902 | 28 | 23 | 0.30 | 17600 | 25300 | 1790 | 2580 |
| 22 ^{+0.038} / _{+0.020} | RNA 4903 | 30 | 13 | 0.30 | 11200 | 14600 | 1140 | 1490 |
| 22 ^{+0.038} / _{+0.020} | RNA 5903 | 30 | 18 | 0.30 | 15200 | 21700 | 1550 | 2210 |
| 22 ^{+0.038} / _{+0.020} | RNA 6903 | 30 | 23 | 0.30 | 18200 | 27200 | 1850 | 2770 |
| 25 ^{+0.038} / _{+0.020} | RNA 4904 | 37 | 17 | 0.30 | 21300 | 25500 | 2170 | 2600 |
| 25 ^{+0.038} / _{+0.020} | RNA 5904 | 37 | 23 | 0.30 | 28400 | 37000 | 2900 | 3750 |
| 25 ^{+0.038} / _{+0.020} | RNA 6904 | 37 | 30 | 0.30 | 36500 | 50500 | 3700 | 5150 |
| 28 ^{+0.038} / _{+0.020} | RNA 49/22 | 39 | 17 | 0.30 | 23200 | 29300 | 2360 | 2990 |
| 28 ^{+0.038} / _{+0.020} | RNA 59/22 | 39 | 23 | 0.30 | 26400 | 37500 | 2690 | 3850 |
| 28 ^{+0.038} / _{+0.020} | RNA 69/22 | 39 | 30 | 0.30 | 40000 | 58500 | 4050 | 6000 |
| 30 ^{+0.038} / _{+0.020} | RNA 4905 | 42 | 17 | 0.30 | 24000 | 31500 | 2450 | 3200 |
| 30 ^{+0.038} / _{+0.020} | RNA 5905 | 42 | 23 | 0.30 | 30500 | 43000 | 3150 | 4350 |
| 30 ^{+0.038} / _{+0.020} | RNA 6905 | 42 | 30 | 0.30 | 41500 | 63000 | 4200 | 6400 |
| 32 ^{+0.041} / _{+0.025} | RNA 49/28 | 45 | 17 | 0.30 | 24800 | 33500 | 2530 | 3400 |
| 32 ^{+0.041} / _{+0.025} | RNA 59/28 | 45 | 23 | 0.30 | 32000 | 45500 | 3250 | 4650 |
| 32 ^{+0.041} / _{+0.025} | RNA 69/28 | 45 | 30 | 0.30 | 43000 | 67000 | 4350 | 6850 |
| 35 ^{+0.041} / _{+0.025} | RNA 4906 | 47 | 17 | 0.30 | 25500 | 35500 | 2600 | 3600 |
| 35 ^{+0.041} / _{+0.025} | RNA 5906 | 47 | 23 | 0.30 | 32500 | 48500 | 3350 | 4950 |
| 35 ^{+0.041} / _{+0.025} | RNA 6906 | 47 | 30 | 0.30 | 42500 | 67500 | 4300 | 6900 |
| 40 ^{+0.041} / _{+0.025} | RNA 49/32 | 52 | 20 | 0.60 | 31500 | 47500 | 3200 | 4850 |
| 40 ^{+0.041} / _{+0.025} | RNA 59/32 | 52 | 27 | 0.60 | 38000 | 61000 | 3850 | 6250 |

Note: 1) These values are the allowable minimum dimensions of the chamfer dimension r

Machined-ring needle roller bearings without inner ring series RNA 49-59-69

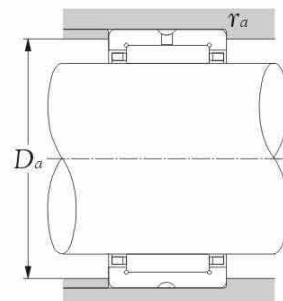
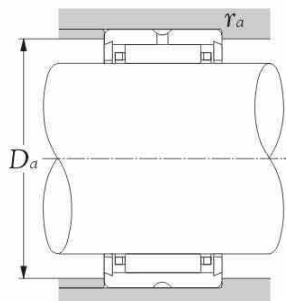

| Max runout speed | | Abutment dimensions | | Weight |
|------------------|-------|---------------------|-----------------|--------|
| grease | oil | D_a max | r_{as} max | kg. |
| r/min | | | | |
| 23000 | 34000 | 8.5 | 0.15 | 0.0055 |
| 21000 | 32000 | 9.5 | 0.15 | 0.0073 |
| 20000 | 30000 | 10.5 | 0.15 | 0.0095 |
| 19000 | 28000 | 12.0 | 0.15 | 0.0130 |
| 17000 | 26000 | 14.0 | 0.30 | 0.0130 |
| 16000 | 24000 | 20.0 | 0.30 | 0.0170 |
| 15000 | 23000 | 22.0 | 0.30 | 0.0170 |
| 15000 | 23000 | 22.0 | 0.30 | 0.0310 |
| 13000 | 20000 | 26.0 | 0.30 | 0.0220 |
| 13000 | 20000 | 26.0 | 0.30 | 0.0330 |
| 13000 | 20000 | 26.0 | 0.30 | 0.0400 |
| 12000 | 18000 | 28.0 | 0.30 | 0.0220 |
| 12000 | 18000 | 28.0 | 0.30 | 0.0350 |
| 12000 | 18000 | 28.0 | 0.30 | 0.0420 |
| 11000 | 16000 | 35.0 | 0.30 | 0.0520 |
| 11000 | 16000 | 35.0 | 0.30 | 0.0840 |
| 11000 | 16000 | 35.0 | 0.30 | 0.1000 |
| 9500 | 14000 | 37.0 | 0.30 | 0.0500 |
| 9500 | 14000 | 37.0 | 0.30 | 0.0920 |
| 9500 | 14000 | 37.0 | 0.30 | 0.1000 |
| 8500 | 13000 | 40.0 | 0.30 | 0.0610 |
| 8500 | 13000 | 40.0 | 0.30 | 0.1010 |
| 8500 | 13000 | 40.0 | 0.30 | 0.1120 |
| 8500 | 13000 | 43.0 | 0.30 | 0.0730 |
| 8500 | 13000 | 43.0 | 0.30 | 0.1080 |
| 8500 | 13000 | 43.0 | 0.30 | 0.1350 |
| 7500 | 11000 | 45.0 | 0.30 | 0.0690 |
| 7500 | 11000 | 45.0 | 0.30 | 0.1080 |
| 7500 | 11000 | 45.0 | 0.30 | 0.1260 |
| 6500 | 10000 | 48.0 | 0.60 | 0.0890 |
| 6500 | 10000 | 48.0 | 0.60 | 0.1490 |



Machined-ring needle roller bearings without inner ring series RNA 49-59-69

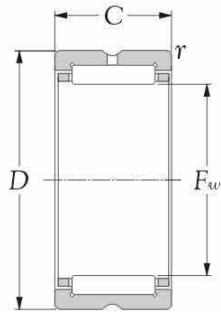

Type RNA 49 ($F_w \geq 14$ mm)
Type RNA 59

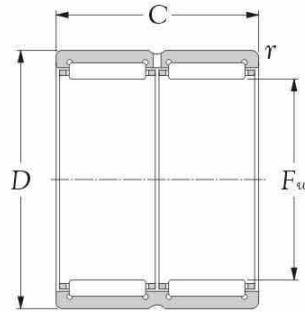

Type RNA 69 ZW ($F_w \geq 40$ mm)

| Inner bore F_w mm | Bearing number | Principal dimensions | | | Basic load ratings | | | |
|--|----------------|----------------------|-----------|------------------------|---------------------|-----------------|-----------------------|-----------------|
| | | D | C mm | r_s mm ¹⁾ | dynamic C N | static C_o | dynamic C kgf | static C_o |
| 40 ^{+0.041} / _{+0.025} | RNA 69/32 ZW | 52 | 36 | 0.6 | 47500 | 82000 | 4850 | 8350 |
| 42 ^{+0.041} / _{+0.025} | RNA 4907 | 55 | 20 | 0.6 | 32000 | 50000 | 3300 | 5100 |
| 42 ^{+0.041} / _{+0.025} | RNA 5907 | 55 | 27 | 0.6 | 39000 | 64500 | 3950 | 6550 |
| 42 ^{+0.041} / _{+0.025} | RNA 6907 ZW | 55 | 36 | 0.6 | 49000 | 86500 | 5000 | 8800 |
| 48 ^{+0.041} / _{+0.025} | RNA 4908 | 62 | 22 | 0.6 | 43500 | 66500 | 4450 | 6800 |
| 48 ^{+0.041} / _{+0.025} | RNA 5908 | 62 | 30 | 0.6 | 53000 | 92500 | 5450 | 9450 |
| 48 ^{+0.041} / _{+0.025} | RNA 6908 ZW | 62 | 40 | 0.6 | 67000 | 116000 | 6850 | 11800 |
| 52 ^{+0.049} / _{+0.030} | RNA 4909 | 68 | 22 | 0.6 | 46000 | 73000 | 4700 | 7450 |
| 52 ^{+0.049} / _{+0.030} | RNA 5909 | 68 | 30 | 0.6 | 56000 | 101000 | 5700 | 10300 |
| 52 ^{+0.049} / _{+0.030} | RNA 6909 | 68 | 40 | 0.6 | 70500 | 127000 | 7200 | 13000 |
| 58 ^{+0.049} / _{+0.030} | RNA 4910 | 72 | 22 | 0.6 | 48000 | 80000 | 4900 | 8150 |
| 58 ^{+0.049} / _{+0.030} | RNA 5910 | 72 | 30 | 0.6 | 58000 | 110000 | 5950 | 11200 |
| 58 ^{+0.049} / _{+0.030} | RNA 6910 ZW | 72 | 40 | 0.6 | 74000 | 139000 | 7500 | 14200 |
| 63 ^{+0.049} / _{+0.030} | RNA 4911 | 80 | 25 | 1.0 | 58500 | 99500 | 6000 | 10100 |
| 63 ^{+0.049} / _{+0.030} | RNA 5911 | 80 | 34 | 1.0 | 76500 | 140000 | 7800 | 14300 |
| 63 ^{+0.049} / _{+0.030} | RNA 6911 ZW | 80 | 45 | 1.0 | 94000 | 183000 | 9600 | 18600 |
| 68 ^{+0.049} / _{+0.030} | RNA 4912 | 85 | 25 | 1.0 | 61500 | 108000 | 6250 | 11000 |
| 68 ^{+0.049} / _{+0.030} | RNA 5912 | 85 | 34 | 1.0 | 80500 | 153000 | 8200 | 15600 |
| 68 ^{+0.049} / _{+0.030} | RNA 6912 ZW | 85 | 45 | 1.0 | 95500 | 191000 | 9750 | 19400 |
| 72 ^{+0.049} / _{+0.030} | RNA 4913 | 90 | 25 | 1.0 | 62500 | 112000 | 6350 | 11400 |
| 72 ^{+0.049} / _{+0.030} | RNA 5913 | 90 | 34 | 1.0 | 84000 | 165000 | 8600 | 16800 |
| 72 ^{+0.049} / _{+0.030} | RNA 6913 ZW | 90 | 45 | 1.0 | 97000 | 198000 | 9900 | 20200 |
| 80 ^{+0.049} / _{+0.030} | RNA 4914 | 100 | 30 | 1.0 | 85500 | 156000 | 8750 | 15900 |
| 80 ^{+0.049} / _{+0.030} | RNA 5914 | 100 | 40 | 1.0 | 103000 | 187000 | 10500 | 19100 |
| 80 ^{+0.049} / _{+0.030} | RNA 6914 ZW | 100 | 54 | 1.0 | 130000 | 267000 | 13300 | 27200 |
| 85 ^{+0.058} / _{+0.036} | RNA 4915 | 105 | 30 | 1.0 | 87000 | 162000 | 8900 | 16500 |
| 85 ^{+0.058} / _{+0.036} | RNA 5915 | 105 | 40 | 1.0 | 109000 | 205000 | 11100 | 20900 |
| 85 ^{+0.058} / _{+0.036} | RNA 6915 ZW | 105 | 54 | 1.0 | 132000 | 277000 | 13500 | 28300 |
| 90 ^{+0.058} / _{+0.036} | RNA 4916 | 110 | 30 | 1.0 | 90500 | 174000 | 9250 | 17700 |
| 90 ^{+0.058} / _{+0.036} | RNA 5916 | 110 | 40 | 1.0 | 115000 | 223000 | 11700 | 22700 |
| 90 ^{+0.058} / _{+0.036} | RNA 6916 ZW | 110 | 54 | 1.0 | 137000 | 298000 | 14000 | 30500 |

Note: 1) These values are the allowable minimum dimensions of the chamfer dimension r

Machined-ring needle roller bearings without inner ring series RNA 49-59-69

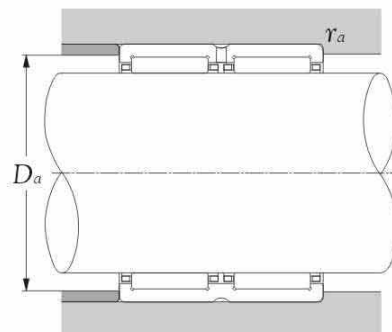
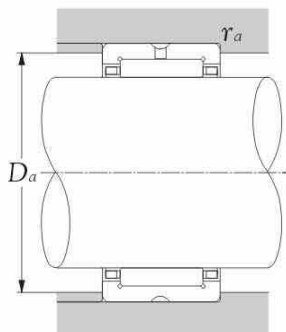

| Max runout speed | | Abutment dimensions | | Weight |
|------------------|-------|---------------------|-------------------|--------|
| grease | oil | D_a max | r_{as} max | kg. |
| r/min | | | | |
| 6500 | 10000 | 48 | 0.6 | 0.162 |
| 6500 | 9500 | 51 | 0.6 | 0.107 |
| 6500 | 9500 | 51 | 0.6 | 0.176 |
| 6500 | 9500 | 51 | 0.6 | 0.193 |
| 5500 | 8500 | 58 | 0.6 | 0.140 |
| 5500 | 8500 | 58 | 0.6 | 0.225 |
| 5500 | 8500 | 58 | 0.6 | 0.256 |
| 5000 | 7500 | 64 | 0.6 | 0.182 |
| 5000 | 7500 | 64 | 0.6 | 0.232 |
| 5000 | 7500 | 64 | 0.6 | 0.273 |
| 4700 | 7000 | 68 | 0.6 | 0.163 |
| 4700 | 7000 | 68 | 0.6 | 0.289 |
| 4700 | 7000 | 68 | 0.6 | 0.320 |
| 4300 | 6500 | 75 | 1.0 | 0.255 |
| 4300 | 6500 | 75 | 1.0 | 0.367 |
| 4300 | 6500 | 75 | 1.0 | 0.470 |
| 4000 | 6000 | 80 | 1.0 | 0.275 |
| 4000 | 6000 | 80 | 1.0 | 0.408 |
| 4000 | 6000 | 80 | 1.0 | 0.488 |
| 3700 | 5500 | 85 | 1.0 | 0.312 |
| 3700 | 5500 | 85 | 1.0 | 0.462 |
| 3700 | 5500 | 85 | 1.0 | 0.520 |
| 3300 | 5000 | 95 | 1.0 | 0.460 |
| 3300 | 5000 | 95 | 1.0 | 0.706 |
| 3300 | 5000 | 95 | 1.0 | 0.857 |
| 3100 | 4700 | 100 | 1.0 | 0.489 |
| 3100 | 4700 | 100 | 1.0 | 0.745 |
| 3100 | 4700 | 100 | 1.0 | 0.935 |
| 2900 | 4400 | 105 | 1.0 | 0.516 |
| 2900 | 4400 | 105 | 1.0 | 0.787 |
| 2900 | 4400 | 105 | 1.0 | 0.987 |



Machined-ring needle roller bearings without inner ring series RNA 48-49-59-69

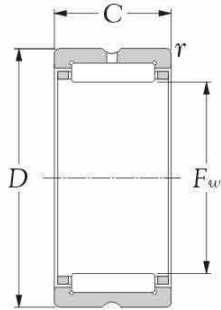

Type RNA 48
Type RNA 49 ($F_w \geq 14$ mm)
Type RNA 59

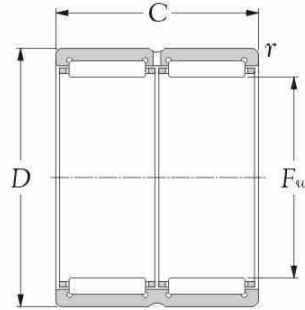

Type RNA 69 ZW ($F_w \geq 40$ mm)

| Inner bore F_w mm | Bearing number | Principal dimensions | | | Basic load ratings | | | |
|---|----------------|----------------------|-----------|------------------------|---------------------|-----------------|-----------------------|-----------------|
| | | D | C mm | r_s mm ¹⁾ | dynamic C N | static C_o | dynamic C kgf | static C_o |
| 100 ^{+0.058} / _{+0.036} | RNA 4917 | 120 | 35 | 1.1 | 112000 | 237000 | 11500 | 24200 |
| 100 ^{+0.058} / _{+0.036} | RNA 5917 | 120 | 46 | 1.1 | 137000 | 290000 | 14000 | 29600 |
| 100 ^{+0.058} / _{+0.036} | RNA 6917 ZW | 120 | 63 | 1.1 | 169000 | 400000 | 17300 | 41000 |
| 105 ^{+0.058} / _{+0.036} | RNA 4918 | 125 | 35 | 1.1 | 116000 | 252000 | 11900 | 25700 |
| 105 ^{+0.058} / _{+0.036} | RNA 5918 | 125 | 46 | 1.1 | 143000 | 310000 | 14600 | 32000 |
| 105 ^{+0.058} / _{+0.036} | RNA 6918 ZW | 125 | 63 | 1.1 | 175000 | 425000 | 17900 | 43500 |
| 110 ^{+0.058} / _{+0.036} | RNA 4919 | 130 | 35 | 1.1 | 118000 | 260000 | 12000 | 26500 |
| 110 ^{+0.058} / _{+0.036} | RNA 5919 | 130 | 46 | 1.1 | 149000 | 335000 | 15200 | 34000 |
| 110 ^{+0.058} / _{+0.036} | RNA 6919 ZW | 130 | 63 | 1.1 | 177000 | 440000 | 18100 | 45000 |
| 115 ^{+0.058} / _{+0.036} | RNA 4920 | 140 | 40 | 1.1 | 127000 | 260000 | 12900 | 26500 |
| 115 ^{+0.058} / _{+0.036} | RNA 5920 | 140 | 54 | 1.1 | 182000 | 395000 | 18600 | 40500 |
| 120 ^{+0.058} / _{+0.036} | RNA 4822 | 140 | 30 | 1.0 | 93500 | 210000 | 9550 | 21400 |
| 125 ^{+0.068} / _{+0.043} | RNA 4922 | 150 | 40 | 1.1 | 131000 | 279000 | 13300 | 28400 |
| 125 ^{+0.068} / _{+0.043} | RNA 5922 | 150 | 54 | 1.1 | 193000 | 440000 | 19700 | 45000 |
| 130 ^{+0.068} / _{+0.043} | RNA 4824 | 150 | 30 | 1.0 | 99500 | 233000 | 10100 | 23800 |
| 135 ^{+0.068} / _{+0.043} | RNA 4924 | 165 | 45 | 1.1 | 180000 | 380000 | 18300 | 38500 |
| 135 ^{+0.068} / _{+0.043} | RNA 5924 | 165 | 60 | 1.1 | 245000 | 525000 | 25000 | 53500 |
| 145 ^{+0.068} / _{+0.043} | RNA 4826 | 165 | 35 | 1.1 | 118000 | 305000 | 12100 | 31000 |
| 150 ^{+0.068} / _{+0.043} | RNA 4926 | 180 | 50 | 1.5 | 202000 | 455000 | 20600 | 46500 |
| 150 ^{+0.068} / _{+0.043} | RNA 5926 | 180 | 67 | 1.5 | 294000 | 685000 | 30000 | 70000 |
| 155 ^{+0.068} / _{+0.043} | RNA 4828 | 175 | 35 | 1.1 | 121000 | 315000 | 12300 | 32500 |
| 160 ^{+0.068} / _{+0.043} | RNA 4928 | 190 | 50 | 1.5 | 209000 | 485000 | 21300 | 49500 |
| 160 ^{+0.068} / _{+0.043} | RNA 5928 | 190 | 67 | 1.5 | 310000 | 755000 | 31500 | 77000 |
| 165 ^{+0.068} / _{+0.043} | RNA 4830 | 190 | 40 | 1.1 | 152000 | 390000 | 15500 | 40000 |
| 170 ^{+0.068} / _{+0.043} | RNA 4930 | 210 | 60 | 2.0 | 261000 | 610000 | 26600 | 62500 |
| 175 ^{+0.068} / _{+0.043} | RNA 4832 | 200 | 40 | 1.1 | 160000 | 425000 | 16300 | 43500 |
| 180 ^{+0.068} / _{+0.043} | RNA 4932 | 220 | 60 | 2.0 | 270000 | 650000 | 27600 | 66500 |
| 185 ^{+0.079} / _{+0.050} | RNA 4834 | 215 | 45 | 1.1 | 185000 | 495000 | 18800 | 50500 |
| 190 ^{+0.079} / _{+0.050} | RNA 4934 | 230 | 60 | 2.0 | 279000 | 690000 | 28500 | 70500 |
| 195 ^{+0.079} / _{+0.050} | RNA 4836 | 225 | 45 | 1.1 | 195000 | 540000 | 19800 | 55000 |
| 205 ^{+0.079} / _{+0.050} | RNA 4936 | 250 | 69 | 2.0 | 375000 | 890000 | 38500 | 90500 |

Note: 1) These values are the allowable minimum dimensions of the chamfer dimension r

Machined-ring needle roller bearings without inner ring series RNA 49-59-69

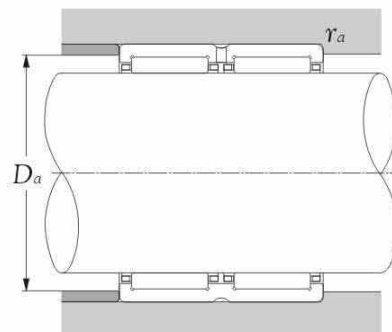
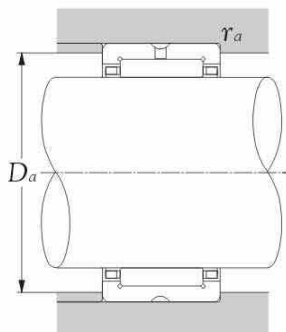

| Max runout speed | | Abutment dimensions | | Weight kg(s). |
|------------------|--------------|---------------------|-----------------|------------------|
| grease r/min | oil r/min | D_a max | r_{as} max | |
| 2700 | 4000 | 113.5 | 1.0 | 0.657 |
| 2700 | 4000 | 113.5 | 1.0 | 1.000 |
| 2700 | 4000 | 113.5 | 1.0 | 1.200 |
| 2500 | 3800 | 118.5 | 1.0 | 0.697 |
| 2500 | 3800 | 118.5 | 1.0 | 1.040 |
| 2500 | 3800 | 118.5 | 1.0 | 1.330 |
| 2400 | 3600 | 123.5 | 1.0 | 0.719 |
| 2400 | 3600 | 123.5 | 1.0 | 1.130 |
| 2400 | 3600 | 123.5 | 1.0 | 1.460 |
| 2300 | 3500 | 133.5 | 1.0 | 1.150 |
| 2300 | 3500 | 133.5 | 1.0 | 1.760 |
| 2200 | 3300 | 135.0 | 1.0 | 0.670 |
| 2100 | 3200 | 143.5 | 1.0 | 1.240 |
| 2100 | 3200 | 143.5 | 1.0 | 1.890 |
| 2100 | 3100 | 145.0 | 1.0 | 0.730 |
| 2000 | 3000 | 158.5 | 1.0 | 1.860 |
| 2000 | 3000 | 158.5 | 1.0 | 2.670 |
| 1900 | 2800 | 158.5 | 1.0 | 0.950 |
| 1800 | 2700 | 172.0 | 1.5 | 2.210 |
| 1800 | 2700 | 172.0 | 1.5 | 3.210 |
| 1700 | 2600 | 168.5 | 1.0 | 1.020 |
| 1700 | 2500 | 182.0 | 1.5 | 2.350 |
| 1700 | 2500 | 182.0 | 1.5 | 3.480 |
| 1600 | 2400 | 183.5 | 1.0 | 1.600 |
| 1600 | 2400 | 201.0 | 2.0 | 2.980 |
| 1500 | 2300 | 193.5 | 1.0 | 1.700 |
| 1500 | 2200 | 211.0 | 2.0 | 3.100 |
| 1500 | 2200 | 208.5 | 1.0 | 2.540 |
| 1400 | 2100 | 221.0 | 2.0 | 3.220 |
| 1400 | 2100 | 218.5 | 1.0 | 2.680 |
| 1300 | 2000 | 241.0 | 2.0 | 4.480 |



Machined-ring needle roller bearings without inner ring series RNA 48-49

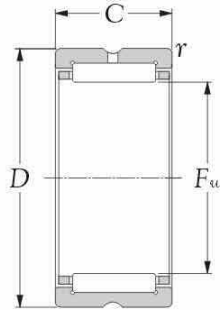

Type RNA 48
Type RNA 49 ($F_w \geq 14$ mm)
Type RNA 59

| Inner bore F_w mm | Bearing number | Principal dimensions | | | Basic load ratings | | | |
|---|----------------|----------------------|-----|------------------------|--------------------|-----------------|----------------|-----------------|
| | | D | C | r_s mm ¹⁾ | dynamic C | static C_o | dynamic C | static C_o |
| | | | mm | | N | | kgf | |
| 210 ^{+0.079} / _{+0.050} | RNA 4838 | 240 | 50 | 1.5 | 227000 | 680000 | 23200 | 69000 |
| 215 ^{+0.079} / _{+0.050} | RNA 4938 | 260 | 69 | 2.0 | 390000 | 945000 | 40000 | 96500 |
| 220 ^{+0.079} / _{+0.050} | RNA 4840 | 250 | 50 | 1.5 | 231000 | 705000 | 23600 | 71500 |
| 225 ^{+0.079} / _{+0.050} | RNA 4940 | 280 | 80 | 2.1 | 505000 | 1180000 | 51500 | 120000 |
| 240 ^{+0.079} / _{+0.050} | RNA 4844 | 270 | 50 | 1.5 | 242000 | 770000 | 24700 | 78500 |
| 245 ^{+0.079} / _{+0.050} | RNA 4944 | 300 | 80 | 2.1 | 525000 | 1270000 | 53500 | 129000 |
| 265 ^{+0.088} / _{+0.056} | RNA 4848 | 300 | 60 | 2.0 | 360000 | 1080000 | 37000 | 110000 |
| 265 ^{+0.088} / _{+0.056} | RNA 4948 | 320 | 80 | 2.1 | 540000 | 1350000 | 55000 | 138000 |
| 285 ^{+0.088} / _{+0.056} | RNA 4852 | 320 | 60 | 2.0 | 375000 | 1160000 | 38000 | 119000 |
| 290 ^{+0.088} / _{+0.056} | RNA 4952 | 360 | 100 | 2.1 | 805000 | 1900000 | 82000 | 193000 |
| 305 ^{+0.088} / _{+0.056} | RNA 4856 | 350 | 69 | 2.0 | 455000 | 1300000 | 46500 | 133000 |
| 310 ^{+0.088} / _{+0.056} | RNA 4956 | 380 | 100 | 2.1 | 835000 | 2030000 | 85000 | 207000 |
| 330 ^{+0.098} / _{+0.062} | RNA 4860 | 380 | 80 | 2.1 | 625000 | 1770000 | 64000 | 180000 |
| 340 ^{+0.098} / _{+0.062} | RNA 4960 | 420 | 118 | 3.0 | 1080000 | 2640000 | 110000 | 269000 |
| 350 ^{+0.098} / _{+0.062} | RNA 4864 | 400 | 80 | 2.1 | 640000 | 1850000 | 655000 | 189000 |
| 360 ^{+0.098} / _{+0.062} | RNA 4964 | 440 | 118 | 3.0 | 1120000 | 2820000 | 114000 | 288000 |
| 370 ^{+0.098} / _{+0.062} | RNA 4868 | 420 | 80 | 2.1 | 665000 | 1940000 | 66500 | 197000 |
| 380 ^{+0.098} / _{+0.062} | RNA 4968 | 460 | 118 | 3.0 | 1160000 | 3000000 | 118000 | 305000 |
| 390 ^{+0.098} / _{+0.062} | RNA 4872 | 440 | 80 | 2.1 | 665000 | 2020000 | 68000 | 206000 |
| 400 ^{+0.108} / _{+0.068} | RNA 4972 | 480 | 118 | 3.0 | 1200000 | 3200000 | 122000 | 325000 |
| 415 ^{+0.108} / _{+0.068} | RNA 4876 | 480 | 100 | 2.1 | 1000000 | 2840000 | 102000 | 289000 |
| 430 ^{+0.108} / _{+0.068} | RNA 4976 | 520 | 140 | 4.0 | 1400000 | 3750000 | 143000 | 385000 |
| 450 ^{+0.108} / _{+0.068} | RNA 4980 | 540 | 140 | 4.0 | 1450000 | 4000000 | 148000 | 410000 |
| 470 ^{+0.108} / _{+0.068} | RNA 4984 | 560 | 140 | 4.0 | 1500000 | 4250000 | 153000 | 430000 |
| 490 ^{+0.108} / _{+0.068} | RNA 4988 | 600 | 160 | 4.0 | 1750000 | 4600000 | 179000 | 470000 |

Note: 1) These values are the allowable minimum dimensions of the chamfer dimension r

Machined-ring needle roller bearings without inner ring series RNA 48-49

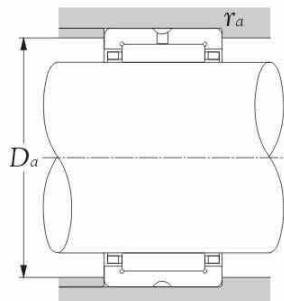

| Max runout speed | | Abutment dimensions | | Weight |
|------------------|------|---------------------|-----------------------------|--------|
| grease | oil | D_a <i>max</i> | γ_{as} <i>max</i> | kgs. |
| r/min | | | | |
| 1300 | 1900 | 232 | 1.5 | 3.210 |
| 1300 | 1900 | 251 | 2.0 | 4.530 |
| 1200 | 1800 | 242 | 1.5 | 3.350 |
| 1200 | 1800 | 269 | 2.0 | 7.200 |
| 1100 | 1700 | 262 | 1.5 | 3.620 |
| 1100 | 1600 | 289 | 2.0 | 7.810 |
| 1000 | 1500 | 291 | 2.0 | 5.400 |
| 1000 | 1500 | 309 | 2.0 | 8.400 |
| 950 | 1400 | 311 | 2.0 | 5.800 |
| 950 | 1400 | 349 | 2.0 | 15.900 |
| 850 | 1300 | 341 | 2.0 | 9.300 |
| 850 | 1300 | 369 | 2.0 | 16.700 |
| 800 | 1200 | 369 | 2.0 | 12.700 |
| 800 | 1200 | 407 | 2.5 | 24.000 |
| 750 | 1100 | 389 | 2.0 | 13.400 |
| 750 | 1100 | 427 | 2.5 | 25.200 |
| 750 | 1100 | 409 | 2.0 | 14.000 |
| 750 | 1100 | 447 | 2.5 | 26.500 |
| 650 | 1000 | 429 | 2.0 | 14.800 |
| 650 | 1000 | 467 | 2.5 | 28.200 |
| 650 | 950 | 469 | 3.0 | 26.000 |
| 650 | 950 | 504 | 3.0 | 38.600 |
| 600 | 900 | 524 | 3.0 | 40.100 |
| 550 | 850 | 544 | 3.0 | 51.600 |
| 550 | 800 | 584 | 3.0 | 66.900 |



Machined-ring needle roller bearings without inner ring series NK

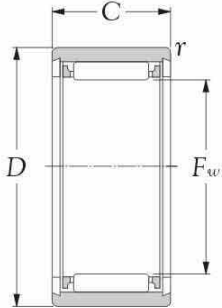

Type NK ($F_w \leq 12$ mm)

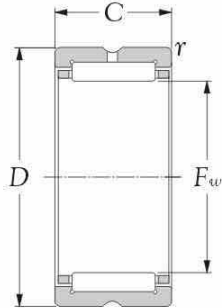

Type NK ($F_w \geq 14$ mm)

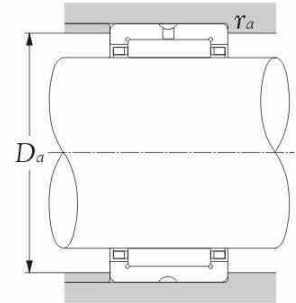
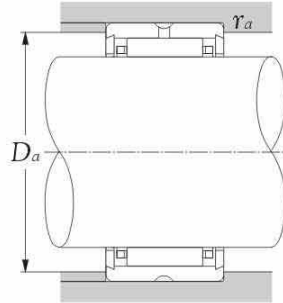

| Inner bore F_w mm | Bearing number | Principal dimensions | | | Basic load ratings | | | | Max runout speed | | Abutment dimensions | | Weight kg. |
|--|----------------|----------------------|-----------|------------------------|--------------------|----------------------|-----------------------|-----------------|------------------|-------|---------------------|--------------|---------------|
| | | D | C mm | r_s mm ¹⁾ | dynamic C | static C_o N | dynamic C kgf | static C_o | grease r/min | oil | D_a max | D_b max | |
| 5 ^{+0.018} / _{+0.010} | NK 5/10 | 10 | 10 | 0.15 | 2640 | 2190 | 269 | 224 | 27000 | 40000 | 6.5 | 0.15 | 0.0031 |
| 5 ^{+0.018} / _{+0.010} | NK 5/12 | 10 | 12 | 0.15 | 2720 | 2250 | 277 | 230 | 27000 | 40000 | 6.5 | 0.15 | 0.0037 |
| 6 ^{+0.018} / _{+0.010} | NK 6/10 | 12 | 10 | 0.15 | 2660 | 2280 | 272 | 233 | 25000 | 37000 | 7.5 | 0.15 | 0.0047 |
| 6 ^{+0.018} / _{+0.010} | NK 6/12 | 12 | 12 | 0.15 | 3400 | 3150 | 345 | 320 | 25000 | 37000 | 7.5 | 0.15 | 0.0057 |
| 7 ^{+0.022} / _{+0.013} | NK 7/10 | 14 | 10 | 0.30 | 2670 | 2350 | 272 | 239 | 23000 | 34000 | 8.5 | 0.30 | 0.0069 |
| 7 ^{+0.022} / _{+0.013} | NK 7/12 | 14 | 12 | 0.30 | 3400 | 3200 | 345 | 330 | 23000 | 34000 | 8.5 | 0.30 | 0.0082 |
| 8 ^{+0.022} / _{+0.013} | NK 8/12 | 15 | 12 | 0.30 | 4000 | 4100 | 410 | 420 | 21000 | 32000 | 9.5 | 0.30 | 0.0087 |
| 8 ^{+0.022} / _{+0.013} | NK 8/16 | 15 | 16 | 0.30 | 4850 | 5200 | 495 | 535 | 21000 | 32000 | 9.5 | 0.30 | 0.0120 |
| 9 ^{+0.022} / _{+0.013} | NK 9/12 | 16 | 12 | 0.30 | 4550 | 5000 | 465 | 510 | 20000 | 30000 | 10.5 | 0.30 | 0.0100 |
| 9 ^{+0.022} / _{+0.013} | NK 9/16 | 16 | 16 | 0.30 | 5500 | 6400 | 560 | 650 | 20000 | 30000 | 10.5 | 0.30 | 0.0130 |
| 10 ^{+0.022} / _{+0.013} | NK 10/12 | 17 | 12 | 0.30 | 4550 | 5100 | 460 | 520 | 19000 | 28000 | 11.5 | 0.30 | 0.0100 |
| 10 ^{+0.022} / _{+0.013} | NK 10/16 | 17 | 16 | 0.30 | 5450 | 6450 | 555 | 660 | 19000 | 28000 | 11.5 | 0.30 | 0.0130 |
| 12 ^{+0.027} / _{+0.016} | NK 12/12 | 19 | 12 | 0.30 | 5000 | 6100 | 510 | 620 | 17000 | 26000 | 13.5 | 0.30 | 0.0130 |
| 12 ^{+0.027} / _{+0.016} | NK 12/16 | 19 | 16 | 0.30 | 6000 | 7700 | 615 | 785 | 17000 | 26000 | 13.5 | 0.30 | 0.0160 |
| 14 ^{+0.027} / _{+0.016} | NK 14/16 | 22 | 16 | 0.30 | 10300 | 11500 | 1050 | 1170 | 16000 | 24000 | 20.0 | 0.30 | 0.0210 |
| 14 ^{+0.027} / _{+0.016} | NK 14/20 | 22 | 20 | 0.30 | 13000 | 15600 | 1330 | 1590 | 16000 | 24000 | 20.0 | 0.30 | 0.0260 |
| 15 ^{+0.027} / _{+0.016} | NK 15/16 | 23 | 16 | 0.30 | 10900 | 12700 | 1110 | 1290 | 15000 | 23000 | 21.0 | 0.30 | 0.0220 |
| 15 ^{+0.027} / _{+0.016} | NK 15/20 | 23 | 20 | 0.30 | 13800 | 17200 | 1410 | 1750 | 15000 | 23000 | 21.0 | 0.30 | 0.0270 |
| 16 ^{+0.027} / _{+0.016} | NK 16/16 | 24 | 16 | 0.30 | 12200 | 14900 | 1240 | 1520 | 15000 | 23000 | 22.0 | 0.30 | 0.0220 |
| 16 ^{+0.027} / _{+0.016} | NK 16/20 | 24 | 20 | 0.30 | 14600 | 18800 | 1490 | 1920 | 15000 | 23000 | 22.0 | 0.30 | 0.0280 |
| 17 ^{+0.027} / _{+0.016} | NK 17/16 | 25 | 16 | 0.30 | 12100 | 15000 | 1240 | 1530 | 15000 | 22000 | 23.0 | 0.30 | 0.0240 |
| 17 ^{+0.027} / _{+0.016} | NK 17/20 | 25 | 20 | 0.30 | 15400 | 20400 | 1570 | 2080 | 15000 | 22000 | 23.0 | 0.30 | 0.0300 |
| 18 ^{+0.027} / _{+0.016} | NK 18/16 | 26 | 16 | 0.30 | 12700 | 16200 | 1300 | 1650 | 14000 | 21000 | 24.0 | 0.30 | 0.0250 |
| 18 ^{+0.027} / _{+0.016} | NK 18/20 | 26 | 20 | 0.30 | 16100 | 22000 | 1640 | 2250 | 14000 | 21000 | 24.0 | 0.30 | 0.0310 |
| 19 ^{+0.033} / _{+0.020} | NK 19/16 | 27 | 16 | 0.30 | 13300 | 17400 | 1350 | 1780 | 14000 | 21000 | 25.0 | 0.30 | 0.0260 |
| 19 ^{+0.033} / _{+0.020} | NK 19/20 | 27 | 20 | 0.30 | 16000 | 22200 | 1630 | 2260 | 14000 | 21000 | 25.0 | 0.30 | 0.0320 |
| 20 ^{+0.033} / _{+0.020} | NK 20/16 | 28 | 16 | 0.30 | 13200 | 17500 | 1340 | 1790 | 13000 | 20000 | 26.0 | 0.30 | 0.0270 |
| 20 ^{+0.033} / _{+0.020} | NK 20/20 | 28 | 20 | 0.30 | 16700 | 23800 | 1700 | 2420 | 13000 | 20000 | 26.0 | 0.30 | 0.0340 |
| 21 ^{+0.033} / _{+0.020} | NK 21/16 | 29 | 16 | 0.30 | 13700 | 18700 | 1400 | 1910 | 13000 | 19000 | 27.0 | 0.30 | 0.0280 |
| 21 ^{+0.033} / _{+0.020} | NK 21/20 | 29 | 20 | 0.30 | 18300 | 27100 | 1860 | 2760 | 13000 | 19000 | 27.0 | 0.30 | 0.0350 |
| 22 ^{+0.033} / _{+0.020} | NK 22/16 | 30 | 16 | 0.30 | 14200 | 19900 | 1450 | 2030 | 12000 | 18000 | 28.0 | 0.30 | 0.0340 |

Note: 1) These values are the allowable minimum dimensions of the chamfer dimension r

Machined-ring needle roller bearings without inner ring series NK

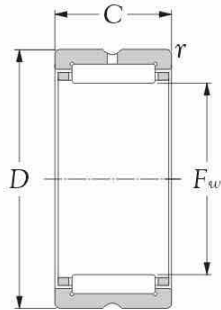

Type NK (Fw ≥ 14 mm)

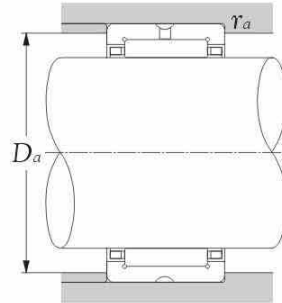

| Inner bore F _w mm | Bearing number | Principal dimensions | | | Basic load ratings | | | | Max runout speed | | Abutment dimensions | | Weight kg. |
|--|----------------|----------------------|---------|---------------------------------|--------------------|----------------|----------|----------------|------------------|--------------|-----------------------|-----------------------|---------------|
| | | D | C mm | r _s mm ¹⁾ | C N | C ₀ | C kgf | C ₀ | grease r/min | oil r/min | D _a max | D _b max | |
| 22 ^{+0.033} / _{+0.020} | NK 22/20 | 30 | 20 | 0.3 | 18000 | 27000 | 1840 | 2760 | 12000 | 18000 | 28 | 0.3 | 0.037 |
| 24 ^{+0.033} / _{+0.020} | NK 24/16 | 32 | 16 | 0.3 | 15200 | 22300 | 1550 | 2280 | 11000 | 17000 | 30 | 0.3 | 0.032 |
| 24 ^{+0.033} / _{+0.020} | NK 24/20 | 32 | 20 | 0.3 | 18600 | 28800 | 1890 | 2930 | 11000 | 17000 | 30 | 0.3 | 0.040 |
| 25 ^{+0.033} / _{+0.020} | NK 25/16 | 33 | 16 | 0.3 | 15100 | 22400 | 1540 | 2280 | 11000 | 16000 | 31 | 0.3 | 0.033 |
| 25 ^{+0.033} / _{+0.020} | NK 25/20 | 33 | 20 | 0.3 | 19200 | 30500 | 1960 | 3100 | 11000 | 16000 | 31 | 0.3 | 0.042 |
| 26 ^{+0.033} / _{+0.020} | NK 26/16 | 34 | 16 | 0.3 | 15600 | 23600 | 1590 | 2410 | 10000 | 15000 | 32 | 0.3 | 0.034 |
| 26 ^{+0.033} / _{+0.020} | NK 26/20 | 34 | 20 | 0.3 | 19100 | 30500 | 1940 | 3100 | 10000 | 15000 | 32 | 0.3 | 0.042 |
| 28 ^{+0.033} / _{+0.020} | NK 28/20 | 37 | 20 | 0.3 | 22300 | 34000 | 2280 | 3450 | 9500 | 14000 | 35 | 0.3 | 0.052 |
| 28 ^{+0.033} / _{+0.020} | NK 28/30 | 37 | 30 | 0.3 | 26700 | 48000 | 2720 | 4900 | 9500 | 14000 | 35 | 0.3 | 0.082 |
| 29 ^{+0.033} / _{+0.020} | NK 29/20 | 38 | 20 | 0.3 | 22200 | 34000 | 2270 | 3450 | 9500 | 14000 | 36 | 0.3 | 0.054 |
| 29 ^{+0.033} / _{+0.020} | NK 29/30 | 38 | 30 | 0.3 | 27500 | 50500 | 2810 | 5150 | 9500 | 14000 | 36 | 0.3 | 0.084 |
| 30 ^{+0.033} / _{+0.020} | NK 30/20 | 40 | 20 | 0.3 | 22100 | 34000 | 2260 | 3500 | 8500 | 13000 | 38 | 0.3 | 0.065 |
| 30 ^{+0.033} / _{+0.020} | NK 30/30 | 40 | 30 | 0.3 | 33000 | 57000 | 3350 | 5800 | 8500 | 13000 | 38 | 0.3 | 0.098 |
| 32 ^{+0.041} / _{+0.025} | NK 32/20 | 42 | 20 | 0.3 | 23500 | 37500 | 2400 | 3850 | 8500 | 13000 | 40 | 0.3 | 0.068 |
| 32 ^{+0.041} / _{+0.025} | NK 32/30 | 42 | 30 | 0.3 | 34000 | 60500 | 3450 | 6150 | 8500 | 13000 | 40 | 0.3 | 0.102 |
| 35 ^{+0.041} / _{+0.025} | NK 35/20 | 45 | 20 | 0.3 | 24800 | 41500 | 2520 | 4250 | 7500 | 11000 | 43 | 0.3 | 0.074 |
| 35 ^{+0.041} / _{+0.025} | NK 35/30 | 45 | 30 | 0.3 | 36000 | 66500 | 3650 | 6800 | 7500 | 11000 | 43 | 0.3 | 0.112 |
| 37 ^{+0.041} / _{+0.025} | NK 37/20 | 47 | 20 | 0.3 | 25300 | 43500 | 2580 | 4400 | 7500 | 11000 | 45 | 0.3 | 0.077 |
| 37 ^{+0.041} / _{+0.025} | NK 37/30 | 47 | 30 | 0.3 | 36500 | 69500 | 3750 | 7100 | 7500 | 11000 | 45 | 0.3 | 0.107 |
| 38 ^{+0.041} / _{+0.025} | NK 38/20 | 48 | 20 | 0.3 | 25900 | 45000 | 2640 | 4600 | 7500 | 11000 | 46 | 0.3 | 0.079 |
| 38 ^{+0.041} / _{+0.025} | NK 38/30 | 48 | 30 | 0.3 | 37500 | 73000 | 3850 | 7400 | 7500 | 11000 | 46 | 0.3 | 0.107 |
| 40 ^{+0.041} / _{+0.025} | NK 40/20 | 50 | 20 | 0.3 | 26400 | 47000 | 2700 | 4800 | 6500 | 10000 | 48 | 0.3 | 0.083 |
| 40 ^{+0.041} / _{+0.025} | NK 40/30 | 50 | 30 | 0.3 | 38500 | 76000 | 3900 | 7750 | 6500 | 10000 | 48 | 0.3 | 0.125 |
| 42 ^{+0.041} / _{+0.025} | NK 42/20 | 52 | 20 | 0.3 | 26900 | 49000 | 2750 | 5000 | 6500 | 9500 | 50 | 0.3 | 0.086 |
| 42 ^{+0.041} / _{+0.025} | NK 42/30 | 52 | 30 | 0.3 | 39000 | 79000 | 4000 | 8050 | 6500 | 9500 | 50 | 0.3 | 0.130 |
| 43 ^{+0.041} / _{+0.025} | NK 43/20 | 53 | 20 | 0.3 | 27500 | 51000 | 2810 | 5200 | 6500 | 9500 | 51 | 0.3 | 0.086 |
| 43 ^{+0.041} / _{+0.025} | NK 43/30 | 53 | 30 | 0.3 | 40000 | 82000 | 4100 | 8400 | 6500 | 9500 | 51 | 0.3 | 0.133 |
| 45 ^{+0.041} / _{+0.025} | NK 45/20 | 55 | 20 | 0.3 | 28000 | 52500 | 2860 | 5400 | 6000 | 9000 | 53 | 0.3 | 0.092 |
| 45 ^{+0.041} / _{+0.025} | NK 45/30 | 55 | 30 | 0.3 | 41000 | 85500 | 4150 | 8700 | 6000 | 9000 | 53 | 0.3 | 0.139 |
| 47 ^{+0.041} / _{+0.025} | NK 47/20 | 57 | 20 | 0.3 | 28800 | 55500 | 2940 | 5650 | 5500 | 8500 | 55 | 0.3 | 0.095 |
| 47 ^{+0.041} / _{+0.025} | NK 47/30 | 57 | 30 | 0.3 | 42500 | 91500 | 4350 | 9350 | 5500 | 8500 | 55 | 0.3 | 0.142 |

Note: 1) These values are the allowable minimum dimensions of the chamfer dimension ?



Machined-ring needle roller bearings without inner ring series NK

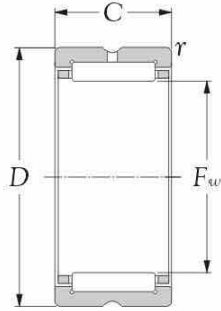

Type NK ($F_w \geq 14$ mm)

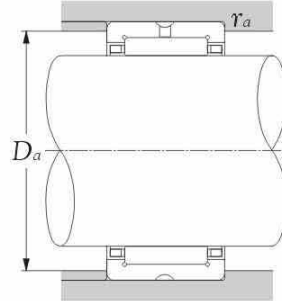

| Inner bore F_w mm | Bearing number | Principal dimensions | | | Basic load ratings | | | | Max runout speed | | Abutment dimensions | | Weight kg. |
|---|----------------|----------------------|----|------------------------|--------------------|--------|-------|-------|------------------|------|---------------------|--------------|---------------|
| | | D | C | r_s mm ¹⁾ | C | C_o | C | C_o | grease | oil | D_a max | D_b max | |
| | | | mm | | N | | kgf | | r/min | | | | |
| 50 ^{+0.041} / _{+0.025} | NK 50/25 | 62 | 25 | 0.6 | 38500 | 74500 | 3950 | 7550 | 5500 | 8000 | 58.0 | 0.6 | 0.158 |
| 50 ^{+0.041} / _{+0.025} | NK 50/35 | 62 | 35 | 0.6 | 51000 | 106000 | 5200 | 10800 | 5500 | 8000 | 58.0 | 0.6 | 0.221 |
| 55 ^{+0.049} / _{+0.030} | NK 55/25 | 68 | 25 | 0.6 | 41000 | 82000 | 4150 | 8400 | 5000 | 7500 | 64.0 | 0.6 | 0.193 |
| 55 ^{+0.049} / _{+0.030} | NK 55/35 | 68 | 35 | 0.6 | 54000 | 118000 | 5500 | 12000 | 5000 | 7500 | 64.0 | 0.6 | 0.267 |
| 60 ^{+0.049} / _{+0.030} | NK 60/25 | 72 | 25 | 0.6 | 41000 | 85000 | 4200 | 8700 | 4300 | 6500 | 68.0 | 0.6 | 0.185 |
| 60 ^{+0.049} / _{+0.030} | NK 60/35 | 72 | 35 | 0.6 | 57000 | 130000 | 5800 | 13200 | 4300 | 6500 | 68.0 | 0.6 | 0.258 |
| 65 ^{+0.049} / _{+0.030} | NK 65/25 | 78 | 25 | 0.6 | 45000 | 98000 | 4550 | 10000 | 4000 | 6000 | 74.0 | 0.6 | 0.221 |
| 65 ^{+0.049} / _{+0.030} | NK 65/35 | 78 | 35 | 0.6 | 60000 | 142000 | 6100 | 14400 | 4000 | 6000 | 74.0 | 0.6 | 0.310 |
| 68 ^{+0.049} / _{+0.030} | NK 68/25 | 82 | 25 | 1.0 | 44500 | 89000 | 4500 | 9050 | 4000 | 6000 | 77.0 | 0.6 | 0.241 |
| 68 ^{+0.049} / _{+0.030} | NK 68/35 | 82 | 35 | 0.6 | 63000 | 139000 | 6400 | 14200 | 4000 | 6000 | 78.0 | 0.6 | 0.338 |
| 70 ^{+0.049} / _{+0.030} | NK 70/25 | 85 | 25 | 0.6 | 45000 | 91500 | 4600 | 9350 | 3700 | 5500 | 81.0 | 0.6 | 0.275 |
| 70 ^{+0.049} / _{+0.030} | NK 70/35 | 85 | 35 | 0.6 | 64000 | 144000 | 6550 | 14700 | 3700 | 5500 | 81.0 | 0.6 | 0.386 |
| 73 ^{+0.049} / _{+0.030} | NK 73/25 | 90 | 25 | 0.6 | 54000 | 100000 | 5500 | 10200 | 3700 | 5500 | 86.0 | 0.6 | 0.302 |
| 73 ^{+0.049} / _{+0.030} | NK 73/35 | 90 | 35 | 0.6 | 76500 | 156000 | 7800 | 16000 | 3700 | 5500 | 86.0 | 0.6 | 0.428 |
| 75 ^{+0.049} / _{+0.030} | NK 75/25 | 92 | 25 | 0.6 | 55000 | 104000 | 5600 | 10600 | 3700 | 5500 | 88.0 | 0.6 | 0.315 |
| 75 ^{+0.049} / _{+0.030} | NK 75/35 | 92 | 35 | 0.6 | 78000 | 162000 | 7950 | 16500 | 3700 | 5500 | 88.0 | 0.6 | 0.492 |
| 80 ^{+0.049} / _{+0.030} | NK 80/25 | 95 | 25 | 1.0 | 57000 | 119000 | 5800 | 12200 | 3300 | 5000 | 90.0 | 1.0 | 0.301 |
| 80 ^{+0.049} / _{+0.030} | NK 80/35 | 95 | 35 | 1.0 | 79500 | 184000 | 8150 | 18700 | 3300 | 5000 | 90.0 | 1.0 | 0.425 |
| 85 ^{+0.058} / _{+0.036} | NK 85/25 | 105 | 25 | 1.0 | 70500 | 123000 | 7200 | 12600 | 3100 | 4700 | 100.0 | 1.0 | 0.404 |
| 85 ^{+0.058} / _{+0.036} | NK 85/35 | 105 | 35 | 1.0 | 100000 | 193000 | 10200 | 19700 | 3100 | 4700 | 100.0 | 1.0 | 0.517 |
| 90 ^{+0.058} / _{+0.036} | NK 90/25 | 110 | 25 | 1.0 | 71500 | 128000 | 7300 | 13100 | 2900 | 4400 | 105.0 | 1.0 | 0.426 |
| 90 ^{+0.058} / _{+0.036} | NK 90/35 | 110 | 35 | 1.0 | 104000 | 208000 | 10600 | 21200 | 2900 | 4400 | 105.0 | 1.0 | 0.604 |
| 95 ^{+0.058} / _{+0.036} | NK 95/26 | 115 | 26 | 1.0 | 74500 | 137000 | 7600 | 14000 | 2800 | 4200 | 110.0 | 1.0 | 0.364 |
| 95 ^{+0.058} / _{+0.036} | NK 95/36 | 115 | 36 | 1.0 | 108000 | 223000 | 11100 | 22700 | 2800 | 4200 | 110.0 | 1.0 | 0.652 |
| 100 ^{+0.058} / _{+0.036} | NK 100/26 | 120 | 26 | 1.0 | 73500 | 137000 | 7500 | 14000 | 2700 | 4000 | 115.0 | 1.0 | 0.487 |
| 100 ^{+0.058} / _{+0.036} | NK 100/36 | 120 | 36 | 1.0 | 107000 | 223000 | 11000 | 22800 | 2700 | 4000 | 115.0 | 1.0 | 0.679 |
| 105 ^{+0.058} / _{+0.036} | NK 105/26 | 125 | 26 | 1.0 | 76500 | 147000 | 7800 | 14900 | 2500 | 3800 | 120.0 | 1.0 | 0.506 |
| 105 ^{+0.058} / _{+0.036} | NK 105/36 | 125 | 36 | 1.0 | 111000 | 238000 | 11400 | 24300 | 2500 | 3800 | 120.0 | 1.0 | 0.713 |
| 110 ^{+0.058} / _{+0.036} | NK 110/30 | 130 | 30 | 1.1 | 97500 | 204000 | 9950 | 20800 | 2400 | 3600 | 123.5 | 1.0 | 0.612 |
| 110 ^{+0.058} / _{+0.036} | NK 110/40 | 130 | 40 | 1.1 | 129000 | 292000 | 13100 | 29700 | 2400 | 3600 | 123.5 | 1.0 | 0.830 |
| 120 ^{+0.058} / _{+0.036} | NK 120/40 | 140 | 40 | 1.1 | 113000 | 268000 | 11500 | 27300 | 2200 | 3300 | 133.5 | 1.0 | 0.910 |

Note: 1) These values are the allowable minimum dimensions of the chamfer dimension r

Machined-ring needle roller bearings without inner ring series NK

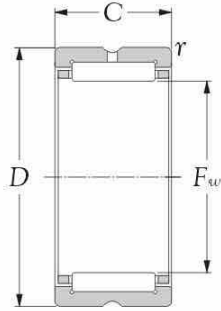

Type NK ($F_w \geq 14$ mm)

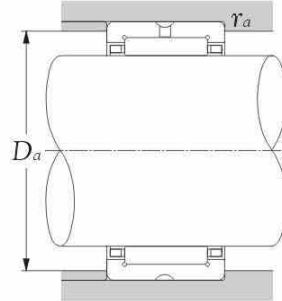

| Inner bore F_w mm | Bearing number | Principal dimensions | | | Basic load ratings | | | | Max runout speed | | Abutment dimensions | | Weight kg(s). |
|---|----------------|----------------------|-----------|----------------------|---------------------|-----------------|-----------------------|-----------------|------------------|------|---------------------|--------------|------------------|
| | | D | C mm | r mm ¹⁾ | dynamic C N | static C_0 | dynamic C kgf | static C_0 | grease r/min | oil | D_a max | D_b max | |
| 130 ^{+0.068} / _{+0.043} | NK 130/40 | 150 | 40 | 1.1 | 116000 | 283000 | 11800 | 28800 | 2100 | 3100 | 143.5 | 1.0 | 0.98 |
| 145 ^{+0.068} / _{+0.043} | NK 145/32 | 170 | 32 | 1.5 | 111000 | 238000 | 11300 | 24300 | 1900 | 2800 | 162.5 | 1.5 | 1.12 |
| 145 ^{+0.068} / _{+0.043} | NK 145/42 | 170 | 42 | 1.5 | 153000 | 360000 | 15600 | 36500 | 1900 | 2800 | 162.5 | 1.5 | 1.49 |
| 155 ^{+0.068} / _{+0.043} | NK 155/32 | 180 | 32 | 1.5 | 114000 | 252000 | 11600 | 25700 | 1700 | 2600 | 172.0 | 1.5 | 1.20 |
| 155 ^{+0.068} / _{+0.043} | NK 155/42 | 180 | 42 | 1.5 | 156000 | 380000 | 16000 | 38500 | 1700 | 2600 | 172.0 | 1.5 | 1.59 |
| 165 ^{+0.068} / _{+0.043} | NK 165/32 | 190 | 32 | 1.5 | 117000 | 265000 | 11900 | 27000 | 1600 | 2400 | 182.0 | 1.5 | 1.42 |
| 165 ^{+0.068} / _{+0.043} | NK 165/42 | 190 | 42 | 1.5 | 160000 | 400000 | 16300 | 40500 | 1600 | 2400 | 182.0 | 1.5 | 1.66 |

Note: 1) These values are the allowable minimum dimensions of the chamfer dimension r



Machined-ring needle roller bearings with inner ring series NKI

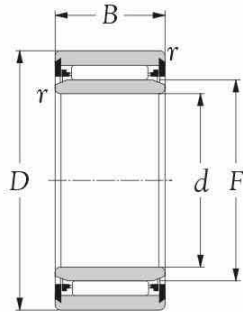

Type NKI ($d \leq 9 \text{ mm}$)

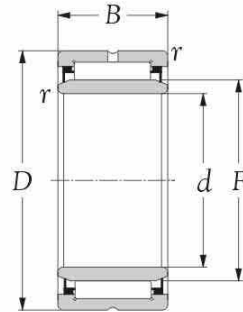

Type NKI ($d \geq 10 \text{ mm}$)

| Inner bore d mm | Bearing number | Principal dimensions | | | | Basic load ratings | | Limiting speed oil r/min | Weight kg. |
|-------------------------|----------------|----------------------|-----|-----|-----------------------|--------------------|-----------------|--------------------------------|---------------|
| | | F | D | B | $r_s \text{ mm}^{-1}$ | dynamic C | static C_0 | | |
| 5 | NKI 5/12 | 8 | 15 | 12 | 0.3 | 3950 | 4100 | 32000 | 0.012 |
| 5 | NKI 5/16 | 8 | 15 | 16 | 0.3 | 5100 | 5800 | 32000 | 0.015 |
| 6 | NKI 6/12 | 9 | 16 | 12 | 0.3 | 4500 | 5000 | 31000 | 0.014 |
| 6 | NKI 6/16 | 9 | 16 | 16 | 0.3 | 5900 | 7100 | 31000 | 0.018 |
| 7 | NKI 7/12 | 10 | 17 | 12 | 0.3 | 4750 | 5500 | 29000 | 0.014 |
| 7 | NKI 7/16 | 10 | 17 | 16 | 0.3 | 6200 | 7800 | 29000 | 0.018 |
| 9 | NKI 9/12 | 12 | 19 | 12 | 0.3 | 6400 | 7100 | 27000 | 0.017 |
| 9 | NKI 9/16 | 12 | 19 | 16 | 0.3 | 9000 | 11000 | 27000 | 0.022 |
| 10 | NKI 10/16 | 14 | 22 | 16 | 0.3 | 10100 | 11500 | 25000 | 0.029 |
| 10 | NKI 10/20 | 14 | 22 | 20 | 0.3 | 12800 | 15600 | 25000 | 0.037 |
| 12 | NKI 12/16 | 16 | 24 | 16 | 0.3 | 11300 | 13900 | 23000 | 0.033 |
| 12 | NKI 12/20 | 16 | 24 | 20 | 0.3 | 14400 | 18800 | 23000 | 0.042 |
| 15 | NKI 15/16 | 19 | 27 | 16 | 0.3 | 13000 | 17400 | 22000 | 0.039 |
| 15 | NKI 15/20 | 19 | 27 | 20 | 0.3 | 16500 | 23600 | 22000 | 0.049 |
| 17 | NKI 17/16 | 21 | 29 | 16 | 0.3 | 13500 | 18700 | 21000 | 0.043 |
| 17 | NKI 17/20 | 21 | 29 | 20 | 0.3 | 17100 | 25500 | 21000 | 0.054 |
| 20 | NKI 20/16 | 24 | 32 | 16 | 0.3 | 15000 | 22300 | 18000 | 0.049 |
| 20 | NKI 20/20 | 24 | 32 | 20 | 0.3 | 19000 | 30500 | 18000 | 0.061 |
| 22 | NKI 22/16 | 26 | 34 | 16 | 0.3 | 15300 | 23600 | 17000 | 0.052 |
| 22 | NKI 22/20 | 26 | 34 | 20 | 0.3 | 19400 | 32000 | 17000 | 0.065 |
| 25 | NKI 25/20 | 29 | 38 | 20 | 0.3 | 21900 | 34000 | 15000 | 0.080 |
| 25 | NKI 25/30 | 29 | 38 | 30 | 0.3 | 32500 | 57000 | 15000 | 0.120 |
| 28 | NKI 28/20 | 32 | 42 | 20 | 0.3 | 23100 | 37500 | 14000 | 0.097 |
| 28 | NKI 28/30 | 32 | 42 | 30 | 0.3 | 34500 | 63000 | 14000 | 0.150 |
| 30 | NKI 30/20 | 35 | 45 | 20 | 0.3 | 24300 | 41500 | 13000 | 0.110 |
| 30 | NKI 30/30 | 35 | 45 | 30 | 0.3 | 36500 | 69000 | 13000 | 0.170 |
| 32 | NKI 32/20 | 37 | 47 | 20 | 0.3 | 24900 | 43500 | 12000 | 0.120 |
| 32 | NKI 32/30 | 37 | 47 | 30 | 0.3 | 37000 | 73000 | 12000 | 0.180 |
| 35 | NKI 35/20 | 40 | 50 | 20 | 0.3 | 26000 | 47000 | 11000 | 0.130 |
| 35 | NKI 35/30 | 40 | 50 | 30 | 0.3 | 39000 | 79000 | 11000 | 0.190 |
| 38 | NKI 38/20 | 43 | 53 | 20 | 0.3 | 27000 | 51000 | 11000 | 0.140 |

Note: 1) These values are the allowable minimum dimensions of the chamfer dimension r

Machined-ring needle roller bearings with inner ring series NKI

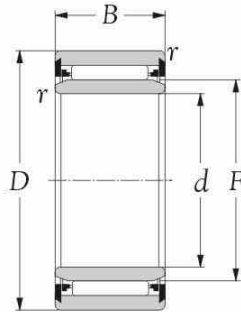

Type NKI ($d \leq 9 \text{ mm}$)

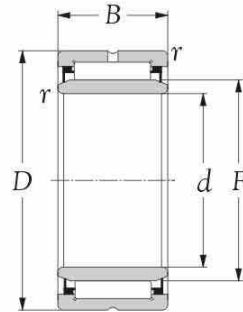

Type NKI ($d \geq 10 \text{ mm}$)

| Inner bore d mm | Bearing number | Principal dimensions | | | | Basic load ratings | | Limiting speed oil r/min | Weight kg(s). |
|-------------------------|----------------|----------------------|-----|-----|-----------------------|--------------------|-----------------|--------------------------------|------------------|
| | | F | D | B | $r_s \text{ mm}^{-1}$ | dynamic C | static C_0 | | |
| 38 | NKI 38/30 | 43 | 53 | 30 | 0.3 | 40500 | 85000 | 11000 | 0.210 |
| 40 | NKI 40/20 | 45 | 55 | 20 | 0.3 | 27500 | 53000 | 10000 | 0.140 |
| 40 | NKI 40/30 | 45 | 55 | 30 | 0.3 | 41000 | 88000 | 10000 | 0.220 |
| 42 | NKI 42/20 | 47 | 57 | 20 | 0.3 | 28500 | 56000 | 10000 | 0.150 |
| 42 | NKI 42/30 | 47 | 57 | 30 | 0.3 | 43000 | 94000 | 10000 | 0.220 |
| 45 | NKI 45/25 | 50 | 62 | 25 | 0.6 | 38000 | 74000 | 9000 | 0.230 |
| 45 | NKI 45/35 | 50 | 62 | 35 | 0.6 | 50000 | 106000 | 9000 | 0.320 |
| 50 | NKI 50/25 | 55 | 68 | 25 | 0.6 | 40000 | 82000 | 8500 | 0.270 |
| 50 | NKI 50/35 | 55 | 68 | 35 | 0.6 | 53000 | 118000 | 8500 | 0.380 |
| 55 | NKI 55/25 | 60 | 72 | 25 | 0.6 | 42000 | 90000 | 7500 | 0.270 |
| 55 | NKI 55/35 | 60 | 72 | 35 | 0.6 | 56000 | 130000 | 7500 | 0.380 |
| 60 | NKI 60/25 | 68 | 82 | 25 | 0.6 | 43500 | 89000 | 7000 | 0.400 |
| 60 | NKI 60/35 | 68 | 82 | 35 | 0.6 | 62000 | 139000 | 7000 | 0.550 |
| 65 | NKI 65/25 | 73 | 90 | 25 | 1.0 | 53000 | 100000 | 6500 | 0.470 |
| 65 | NKI 65/35 | 73 | 90 | 35 | 1.0 | 75000 | 156000 | 6500 | 0.660 |
| 70 | NKI 70/25 | 80 | 95 | 25 | 1.0 | 56000 | 119000 | 6000 | 0.520 |
| 70 | NKI 70/35 | 80 | 95 | 35 | 1.0 | 78000 | 184000 | 6000 | 0.740 |
| 75 | NKI 75/25 | 85 | 105 | 25 | 1.0 | 69000 | 123000 | 5500 | 0.640 |
| 75 | NKI 75/35 | 85 | 105 | 35 | 1.0 | 98000 | 193000 | 5500 | 0.910 |
| 80 | NKI 80/25 | 90 | 110 | 25 | 1.0 | 72000 | 132000 | 5000 | 0.680 |
| 80 | NKI 80/35 | 90 | 110 | 35 | 1.0 | 103000 | 208000 | 5000 | 0.960 |
| 85 | NKI 85/26 | 95 | 115 | 26 | 1.0 | 73000 | 137000 | 4800 | 0.750 |
| 85 | NKI 85/36 | 95 | 115 | 36 | 1.0 | 107000 | 223000 | 4800 | 1.050 |
| 90 | NKI 90/26 | 100 | 120 | 26 | 1.0 | 76000 | 146000 | 4600 | 0.780 |
| 90 | NKI 90/36 | 100 | 120 | 36 | 1.0 | 111000 | 237000 | 4600 | 1.100 |
| 95 | NKI 95/26 | 105 | 125 | 26 | 1.0 | 78000 | 155000 | 4400 | 0.820 |
| 95 | NKI 95/36 | 105 | 125 | 36 | 1.0 | 114000 | 250000 | 4400 | 1.150 |
| 100 | NKI 100/30 | 110 | 130 | 30 | 1.1 | 98000 | 210000 | 4200 | 1.000 |
| 100 | NKI 100/40 | 110 | 130 | 40 | 1.1 | 127000 | 290000 | 4200 | 1.350 |

Note: 1) These values are the allowable minimum dimensions of the chamfer dimension r



Machined-ring needle roller bearings, Separable



TECHNICAL SUPPLEMENT

T086

PRODUCT INFORMATION

P088 - 095



RNAO

P088 - 091



NAO

P092 - 095

1. Bearing materials

The available **KSM** Machined Ring Needle Roller Bearings, Separable, include the series RNAO (without inner ring) and series NAO (with inner ring). The cage used for **KSM** Machined Ring Needle Roller Bearings, Separable, is usually a machined ring type. However, cages of molded polyamide reinforced with glass fiber or carbon fiber (suffix TV) may be used. The TV cage features a maximum allowable operating temperature of 120 °C and maximum allowable continuous operating temperature of 100 °C.

2. Interpreting bearing numbers

The bearing numbers of **KSM** Machined Ring Needle Roller Bearings, Separable, comprise a series number (RNAO, NAO), dimension code (inscribed enveloping circle diameter or bore diameter X outside diameter X width), and suffix (Fig. 1~3).

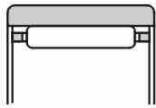

Fig. 1 Series RNAO

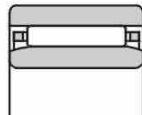

Fig. 2 Series NAO

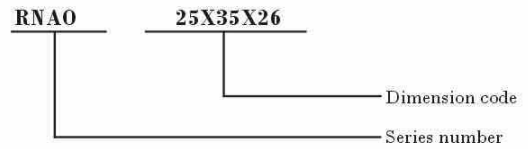
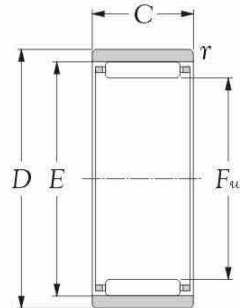

Fig. 3

Machined-ring needle roller bearings, separable series RNAO



| Inner bore F_w mm | Bearing number | Boundary dimensions | | | | Basic load ratings (Radial) | | | |
|--|-----------------|---------------------|------|-----------------------|-----|-----------------------------|-----------------|----------------|-----------------|
| | | D | C | $r_s \text{ mm}^{1)}$ | E | dynamic C | static C_o | dynamic C | static C_o |
| | | mm | | | | N | kgf | | |
| 5 ^{+0.018} / _{+0.010} | RNAO 5x10x8 | 10 | 8.0 | 0.15 | 8 | 2640 | 2190 | 269 | 224 |
| 6 ^{+0.018} / _{+0.010} | RNAO 6x13x8 | 13 | 8.0 | 0.30 | 9 | 2660 | 2280 | 272 | 233 |
| 7 ^{+0.022} / _{+0.013} | RNAO 7x14x8 | 14 | 8.0 | 0.30 | 10 | 2670 | 2350 | 272 | 239 |
| 8 ^{+0.022} / _{+0.013} | RNAO 8x15x10 | 15 | 10.0 | 0.30 | 11 | 4000 | 4100 | 410 | 420 |
| 10 ^{+0.022} / _{+0.013} | RNAO 10x17x10 | 17 | 10.0 | 0.30 | 13 | 4550 | 5100 | 460 | 520 |
| 10 ^{+0.022} / _{+0.013} | RNAO 10x20x12 | 20 | 12.0 | 0.30 | 16 | 7100 | 5950 | 720 | 610 |
| 12 ^{+0.027} / _{+0.016} | RNAO 12x19x13.5 | 19 | 13.5 | 0.30 | 15 | 6000 | 7700 | 615 | 785 |
| 12 ^{+0.027} / _{+0.016} | RNAO 12x22x12 | 22 | 12.0 | 0.30 | 18 | 8650 | 8000 | 880 | 815 |
| 14 ^{+0.027} / _{+0.016} | RNAO 14x22x13 | 22 | 13.0 | 0.30 | 18 | 8300 | 10100 | 845 | 1030 |
| 14 ^{+0.027} / _{+0.016} | RNAO 14x26x12 | 26 | 12.0 | 0.30 | 20 | 9350 | 9150 | 955 | 930 |
| 15 ^{+0.027} / _{+0.016} | RNAO 15x23x13 | 23 | 13.0 | 0.30 | 19 | 8250 | 10200 | 840 | 1040 |
| 16 ^{+0.027} / _{+0.016} | RNAO 16x24x13 | 24 | 13.0 | 0.30 | 20 | 9050 | 11800 | 925 | 1200 |
| 16 ^{+0.027} / _{+0.016} | RNAO 16x28x12 | 28 | 12.0 | 0.30 | 22 | 11700 | 12500 | 1190 | 1280 |
| 17 ^{+0.027} / _{+0.016} | RNAO 17x25x13 | 25 | 13.0 | 0.30 | 21 | 9400 | 12600 | 960 | 1280 |
| 18 ^{+0.027} / _{+0.016} | RNAO 18x26x13 | 26 | 13.0 | 0.30 | 22 | 8900 | 11900 | 910 | 1210 |
| 18 ^{+0.027} / _{+0.016} | RNAO 18x30x12 | 30 | 12.0 | 0.30 | 24 | 12300 | 13800 | 1250 | 1410 |
| 20 ^{+0.033} / _{+0.020} | RNAO 20x28x13 | 28 | 13.0 | 0.30 | 24 | 10000 | 14300 | 1020 | 1460 |
| 20 ^{+0.033} / _{+0.020} | RNAO 20x32x12 | 32 | 12.0 | 0.30 | 26 | 12900 | 15100 | 1320 | 1540 |
| 22 ^{+0.033} / _{+0.020} | RNAO 22x30x13 | 30 | 13.0 | 0.30 | 26 | 10200 | 15200 | 1040 | 1550 |
| 22 ^{+0.033} / _{+0.020} | RNAO 22x35x16 | 35 | 16.0 | 0.30 | 29 | 18700 | 22700 | 1910 | 2310 |
| 25 ^{+0.033} / _{+0.020} | RNAO 25x35x17 | 35 | 17.0 | 0.30 | 29 | 14200 | 24000 | 1450 | 2450 |
| 25 ^{+0.033} / _{+0.020} | RNAO 25x37x16 | 37 | 16.0 | 0.30 | 32 | 19500 | 24700 | 1990 | 2520 |
| 26 ^{+0.033} / _{+0.020} | RNAO 26x39x13 | 39 | 13.0 | 0.30 | 30 | 11800 | 19200 | 1200 | 1960 |
| 28 ^{+0.033} / _{+0.020} | RNAO 28x40x16 | 40 | 16.0 | 0.30 | 35 | 21200 | 28400 | 2160 | 2900 |
| 30 ^{+0.033} / _{+0.020} | RNAO 30x40x17 | 40 | 17.0 | 0.30 | 35 | 19400 | 32500 | 1970 | 3350 |
| 30 ^{+0.033} / _{+0.020} | RNAO 30x42x16 | 42 | 16.0 | 0.30 | 37 | 21900 | 30500 | 2230 | 3100 |
| 32 ^{+0.041} / _{+0.025} | RNAO 32x42x13 | 42 | 13.0 | 0.30 | 37 | 14500 | 23000 | 1480 | 2350 |
| 35 ^{+0.041} / _{+0.025} | RNAO 35x45x13 | 45 | 13.0 | 0.30 | 40 | 15200 | 25100 | 1550 | 2560 |
| 35 ^{+0.041} / _{+0.025} | RNAO 35x45x17 | 45 | 17.0 | 0.30 | 40 | 20000 | 36000 | 2040 | 3650 |
| 35 ^{+0.041} / _{+0.025} | RNAO 35x47x16 | 47 | 16.0 | 0.30 | 42 | 24100 | 36000 | 2450 | 3650 |
| 35 ^{+0.041} / _{+0.025} | RNAO 35x47x18 | 47 | 18.0 | 0.30 | 42 | 24700 | 37000 | 2510 | 3750 |
| 37 ^{+0.041} / _{+0.025} | RNAO 37x47x13 | 47 | 13.0 | 0.30 | 42 | 15900 | 27100 | 1620 | 2770 |

Notes: 1) These values are the allowable minimum dimensions of the chamfer dimension r_s .

Machined-ring needle roller bearings, separable series RNAO

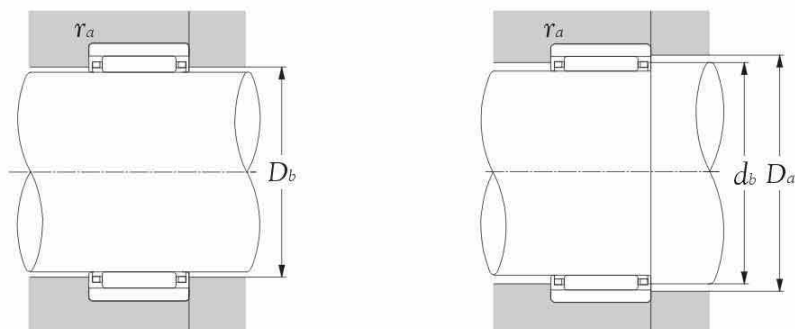

| Max runout speed | | Abutment dimensions | | | | Weight |
|------------------|-------|---------------------|---------------------|---------------------|---------------------|--------|
| grease | oil | D_b <i>min</i> | D_a <i>max</i> | d_b <i>min</i> | r_a <i>max</i> | kg. |
| r/min | | | | | | |
| 27000 | 40000 | 7.7 | 8.8 | 5.3 | 0.15 | 0.003 |
| 25000 | 37000 | 8.7 | 11.0 | 6.3 | 0.30 | 0.006 |
| 23000 | 34000 | 9.7 | 12.0 | 7.3 | 0.30 | 0.006 |
| 21000 | 32000 | 10.7 | 13.0 | 8.3 | 0.30 | 0.008 |
| 19000 | 28000 | 12.7 | 15.0 | 10.3 | 0.30 | 0.010 |
| 19000 | 28000 | 15.7 | 18.0 | 10.3 | 0.30 | 0.018 |
| 17000 | 26000 | 14.7 | 17.0 | 12.3 | 0.30 | 0.015 |
| 17000 | 26000 | 17.6 | 20.0 | 12.3 | 0.30 | 0.019 |
| 16000 | 24000 | 17.6 | 20.0 | 14.4 | 0.30 | 0.018 |
| 16000 | 24000 | 19.6 | 24.0 | 14.4 | 0.30 | 0.029 |
| 15000 | 23000 | 18.6 | 21.0 | 15.4 | 0.30 | 0.020 |
| 15000 | 23000 | 19.6 | 22.0 | 16.4 | 0.30 | 0.021 |
| 15000 | 23000 | 21.6 | 26.0 | 16.4 | 0.30 | 0.032 |
| 15000 | 22000 | 20.6 | 23.0 | 17.4 | 0.30 | 0.022 |
| 14000 | 21000 | 21.6 | 24.0 | 18.4 | 0.30 | 0.022 |
| 14000 | 21000 | 23.6 | 28.0 | 18.4 | 0.30 | 0.035 |
| 13000 | 20000 | 23.6 | 26.0 | 20.4 | 0.30 | 0.025 |
| 13000 | 20000 | 25.6 | 30.0 | 20.4 | 0.30 | 0.038 |
| 12000 | 18000 | 25.6 | 28.0 | 22.4 | 0.30 | 0.027 |
| 12000 | 18000 | 28.4 | 33.0 | 22.4 | 0.30 | 0.059 |
| 11000 | 16000 | 28.4 | 33.0 | 25.6 | 0.30 | 0.053 |
| 11000 | 16000 | 31.4 | 35.0 | 25.6 | 0.30 | 0.060 |
| 10000 | 15000 | 29.4 | 37.0 | 26.6 | 0.30 | 0.060 |
| 9500 | 14000 | 34.4 | 38.0 | 28.6 | 0.30 | 0.061 |
| 9000 | 13000 | 34.4 | 38.0 | 30.6 | 0.30 | 0.060 |
| 9000 | 13000 | 36.4 | 40.0 | 30.6 | 0.30 | 0.069 |
| 8500 | 13000 | 36.4 | 40.0 | 32.6 | 0.30 | 0.049 |
| 7500 | 11000 | 39.4 | 43.0 | 35.6 | 0.30 | 0.053 |
| 7500 | 11000 | 39.4 | 43.0 | 35.6 | 0.30 | 0.069 |
| 7500 | 11000 | 41.4 | 45.0 | 35.6 | 0.30 | 0.078 |
| 7500 | 11000 | 41.4 | 45.0 | 35.6 | 0.30 | 0.089 |
| 7000 | 11000 | 41.4 | 45.0 | 37.6 | 0.30 | 0.056 |

Machined-ring needle roller bearings, separable series RNAO

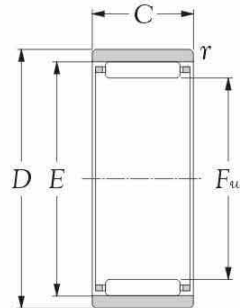

| Inner bore F_w mm | Bearing number | Boundary dimensions | | | | Basic load ratings (Radial) | | | |
|---|-----------------|---------------------|-----|-----------------------|-----|-----------------------------|-----------------|----------------|-----------------|
| | | D | C | $r_s \text{ mm}^{1)}$ | E | dynamic C | static C_o | dynamic C | static C_o |
| | | | | mm | | N | | kgf | |
| 37 ^{+0.041} / _{+0.025} | RNAO 37x52x18 | 52 | 18 | 0.3 | 44 | 26300 | 41000 | 2680 | 4150 |
| 40 ^{+0.041} / _{+0.025} | RNAO 40x50x17 | 50 | 17 | 0.3 | 45 | 21800 | 41500 | 2220 | 4250 |
| 40 ^{+0.041} / _{+0.025} | RNAO 40x55x20 | 55 | 20 | 0.3 | 47 | 31000 | 51500 | 3150 | 5250 |
| 45 ^{+0.041} / _{+0.025} | RNAO 45x55x17 | 55 | 17 | 0.3 | 50 | 22300 | 44500 | 2280 | 4550 |
| 45 ^{+0.041} / _{+0.025} | RNAO 45x62x20 | 62 | 20 | 0.3 | 53 | 36000 | 59000 | 3650 | 6000 |
| 50 ^{+0.041} / _{+0.025} | RNAO 50x62x20 | 62 | 20 | 0.3 | 55 | 27900 | 62000 | 2850 | 6300 |
| 50 ^{+0.041} / _{+0.025} | RNAO 50x65x20 | 65 | 20 | 0.3 | 58 | 38500 | 67500 | 3950 | 6850 |
| 55 ^{+0.049} / _{+0.060} | RNAO 55x68x20 | 68 | 20 | 0.6 | 60 | 28800 | 66500 | 2940 | 6750 |
| 55 ^{+0.049} / _{+0.030} | RNAO 55x68x25 | 68 | 25 | 0.6 | 63 | 50500 | 97500 | 5150 | 9950 |
| 55 ^{+0.049} / _{+0.030} | RNAO 55x72x20 | 72 | 20 | 0.6 | 63 | 39000 | 70000 | 3950 | 7100 |
| 60 ^{+0.049} / _{+0.030} | RNAO 60x78x20 | 78 | 20 | 1.0 | 68 | 40000 | 75000 | 4100 | 7650 |
| 65 ^{+0.049} / _{+0.030} | RNAO 65x85x30 | 85 | 30 | 1.0 | 73 | 61000 | 132000 | 6200 | 13400 |
| 70 ^{+0.049} / _{+0.030} | RNAO 70x90x30 | 90 | 30 | 1.0 | 78 | 65500 | 149000 | 6700 | 15200 |
| 75 ^{+0.049} / _{+0.030} | RNAO 75x95x30 | 95 | 30 | 1.0 | 83 | 67500 | 157000 | 6850 | 16100 |
| 80 ^{+0.049} / _{+0.030} | RNAO 80x95x30 | 95 | 30 | 1.0 | 86 | 57000 | 159000 | 5800 | 16200 |
| 80 ^{+0.049} / _{+0.030} | RNAO 80x100x30 | 100 | 30 | 1.0 | 88 | 69000 | 166000 | 7050 | 17000 |
| 85 ^{+0.058} / _{+0.036} | RNAO 85x105x25 | 105 | 25 | 1.0 | 93 | 61500 | 146000 | 6250 | 14900 |
| 85 ^{+0.058} / _{+0.036} | RNAO 85x105x30 | 105 | 30 | 1.0 | 93 | 71000 | 175000 | 7200 | 17900 |
| 90 ^{+0.058} / _{+0.036} | RNAO 90x105x26 | 105 | 26 | 1.0 | 98 | 64000 | 157000 | 6550 | 16000 |
| 90 ^{+0.058} / _{+0.036} | RNAO 90x110x30 | 110 | 30 | 1.0 | 98 | 72500 | 184000 | 7400 | 18800 |
| 95 ^{+0.058} / _{+0.036} | RNAO 95x115x30 | 115 | 30 | 1.0 | 103 | 74000 | 193000 | 7550 | 19600 |
| 100 ^{+0.058} / _{+0.035} | RNAO 100x120x30 | 120 | 30 | 1.0 | 108 | 76000 | 201000 | 7700 | 20500 |

Notes: 1) These values are the allowable minimum dimensions of the chamfer dimension r_s .



Machined-ring needle roller bearings, separable series RNAO

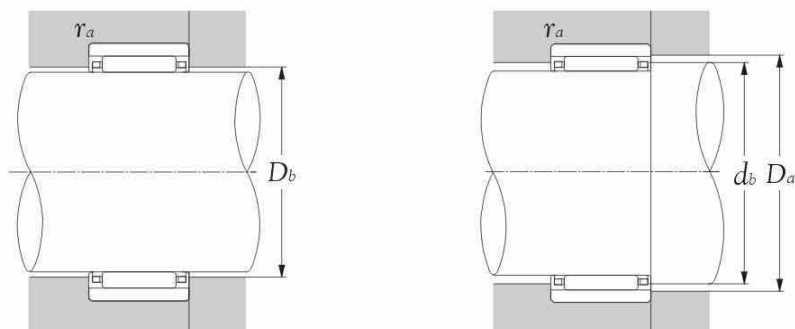

| Max runout speed | | Abutment dimensions | | | | Weight |
|------------------|-------|---------------------|---------------------|---------------------|---------------------|--------|
| grease | oil | D_b <i>min</i> | D_a <i>max</i> | d_b <i>min</i> | r_a <i>max</i> | kg. |
| r/min | | | | | | |
| 7000 | 11000 | 43.4 | 50 | 37.6 | 0.3 | 0.125 |
| 6500 | 10000 | 44.4 | 48 | 40.6 | 0.3 | 0.074 |
| 6500 | 10000 | 46.2 | 53 | 40.6 | 0.3 | 0.145 |
| 6000 | 9000 | 49.2 | 53 | 45.6 | 0.3 | 0.083 |
| 6000 | 9000 | 52.2 | 60 | 45.6 | 0.3 | 0.175 |
| 5500 | 8000 | 54.2 | 60 | 50.6 | 0.3 | 0.140 |
| 5500 | 8000 | 57.2 | 63 | 50.6 | 0.3 | 0.168 |
| 4800 | 7500 | 59.4 | 64 | 55.8 | 0.6 | 0.166 |
| 4800 | 7500 | 62.4 | 64 | 55.8 | 0.6 | 0.200 |
| 4800 | 7500 | 62.4 | 68 | 55.8 | 0.6 | 0.216 |
| 4400 | 6500 | 67.2 | 73 | 60.8 | 1.0 | 0.255 |
| 4100 | 6000 | 72.2 | 80 | 66.0 | 1.0 | 0.464 |
| 3800 | 5500 | 77.2 | 85 | 71.0 | 1.0 | 0.199 |
| 3600 | 5500 | 82.2 | 90 | 76.0 | 1.0 | 0.520 |
| 3300 | 5000 | 85.2 | 90 | 81.0 | 1.0 | 0.405 |
| 3300 | 5000 | 87.2 | 95 | 81.0 | 1.0 | 0.580 |
| 3100 | 4700 | 92.2 | 100 | 86.0 | 1.0 | 0.459 |
| 3100 | 4700 | 92.2 | 100 | 86.0 | 1.0 | 0.585 |
| 3000 | 4400 | 97.2 | 100 | 91.0 | 1.0 | 0.373 |
| 3000 | 4400 | 97.2 | 105 | 91.0 | 1.0 | 0.610 |
| 2800 | 4200 | 102.2 | 110 | 96.0 | 1.0 | 0.640 |
| 2700 | 4000 | 107.2 | 115 | 101.0 | 1.0 | 0.694 |

Machined-ring needle roller bearings, separable series NAO

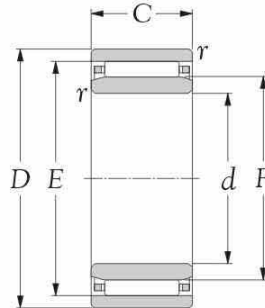

| Inner bore <i>d</i> mm | Bearing number | Boundary dimensions | | | | | Basic load ratings (Radial) | | | |
|------------------------------|----------------|---------------------|----------|-------------------------|----------|----------|-----------------------------|--|----------------------------|---------------------------------|
| | | <i>D</i> | <i>C</i> | $r \leq \text{mm}^{1)}$ | <i>F</i> | <i>E</i> | dynamic <i>C</i> N | static <i>C</i> ₀ kgf | dynamic <i>C</i> kgf | static <i>C</i> ₀ |
| 6 | NAO 6x17x10 | 17 | 10 | 0.3 | 10 | 13 | 4550 | 5100 | 460 | 520 |
| 7 | NAO 7x20x12 | 20 | 12 | 0.3 | 10 | 16 | 7100 | 5950 | 720 | 610 |
| 9 | NAO 9x22x12 | 22 | 12 | 0.3 | 12 | 18 | 8650 | 8000 | 880 | 815 |
| 10 | NAO 10x22x13 | 22 | 13 | 0.3 | 14 | 18 | 8300 | 10100 | 845 | 1030 |
| 10 | NAO 10x26x12 | 26 | 12 | 0.3 | 14 | 20 | 9350 | 9150 | 955 | 930 |
| 12 | NAO 12x24x13 | 24 | 13 | 0.3 | 16 | 20 | 9050 | 11800 | 925 | 1200 |
| 12 | NAO 12x28x12 | 28 | 12 | 0.3 | 16 | 22 | 11700 | 12500 | 1190 | 1280 |
| 15 | NAO 15x28x13 | 28 | 13 | 0.3 | 20 | 24 | 10000 | 14300 | 1020 | 1460 |
| 15 | NAO 15x32x12 | 32 | 12 | 0.3 | 20 | 26 | 12900 | 15100 | 1320 | 1540 |
| 17 | NAO 17x30x13 | 30 | 13 | 0.3 | 22 | 26 | 10200 | 15200 | 1040 | 1550 |
| 17 | NAO 17x35x16 | 35 | 16 | 0.3 | 22 | 29 | 18700 | 22700 | 1910 | 2310 |
| 20 | NAO 20x35x17 | 35 | 17 | 0.3 | 25 | 29 | 14200 | 24000 | 1450 | 2450 |
| 20 | NAO 20x37x16 | 37 | 16 | 0.3 | 25 | 32 | 19500 | 24700 | 1990 | 2520 |
| 25 | NAO 25x40x17 | 40 | 17 | 0.3 | 30 | 35 | 19400 | 32500 | 1970 | 3350 |
| 25 | NAO 25x42x16 | 42 | 16 | 0.3 | 30 | 37 | 21900 | 30500 | 2230 | 3100 |
| 29 | NAO 29x42x13 | 42 | 13 | 0.3 | 32 | 37 | 14500 | 23000 | 1480 | 2350 |
| 30 | NAO 30x45x13 | 45 | 13 | 0.3 | 35 | 40 | 15200 | 25100 | 1550 | 2560 |
| 30 | NAO 30x45x17 | 45 | 17 | 0.3 | 35 | 40 | 20000 | 36000 | 2040 | 3650 |
| 30 | NAO 30x47x16 | 47 | 16 | 0.3 | 35 | 42 | 24100 | 36000 | 2450 | 3650 |
| 30 | NAO 30x47x18 | 47 | 18 | 0.3 | 35 | 42 | 24700 | 37000 | 2510 | 3750 |
| 30 | NAO 30x52x18 | 52 | 18 | 0.3 | 37 | 44 | 26300 | 41000 | 2680 | 4150 |
| 33 | NAO 33x47x13 | 47 | 13 | 0.3 | 37 | 42 | 15900 | 27100 | 1620 | 2770 |
| 35 | NAO 35x50x17 | 50 | 17 | 0.3 | 40 | 45 | 21800 | 41500 | 2220 | 4250 |
| 35 | NAO 35x55x20 | 55 | 20 | 0.3 | 40 | 47 | 31000 | 51500 | 3150 | 5250 |
| 40 | NAO 40x55x17 | 55 | 17 | 0.3 | 45 | 50 | 22300 | 44500 | 2280 | 4550 |
| 40 | NAO 40x62x20 | 62 | 20 | 0.3 | 45 | 53 | 36000 | 59000 | 3650 | 6000 |
| 40 | NAO 40x65x20 | 65 | 20 | 0.3 | 50 | 58 | 38500 | 67500 | 3950 | 6850 |
| 45 | NAO 45x62x20 | 62 | 20 | 0.3 | 50 | 55 | 27900 | 62000 | 2850 | 6300 |
| 45 | NAO 45x72x20 | 72 | 20 | 0.6 | 55 | 63 | 39000 | 70000 | 3950 | 7100 |
| 50 | NAO 50x68x20 | 68 | 20 | 0.6 | 55 | 60 | 28800 | 66500 | 2940 | 6750 |
| 50 | NAO 50x78x20 | 78 | 20 | 1.0 | 60 | 68 | 40000 | 75000 | 4100 | 7650 |
| 55 | NAO 55x85x30 | 85 | 30 | 1.0 | 65 | 73 | 61000 | 132000 | 6200 | 13400 |

Notes: 1) These values are the allowable minimum dimensions of the chamfer dimension r .

Machined-ring needle roller bearings, separable series NAO

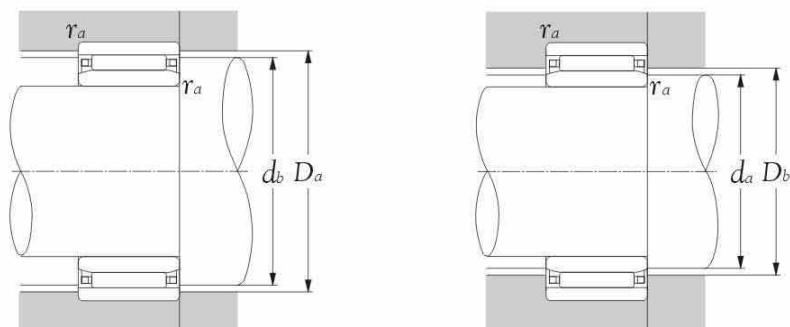

| Max runout speed | | Abutment dimensions | | | | | Weight |
|------------------|-------|---------------------|-------|--------------|-------|--------------|--------|
| grease | oil | d_a mm | d_b | D_a max | D_b | r_a max | kg. |
| r/min | | | | | | | |
| 19000 | 28000 | 8 | 12.7 | 15 | 10.3 | 0.3 | 0.014 |
| 19000 | 28000 | 9 | 15.7 | 18 | 10.3 | 0.3 | 0.022 |
| 17000 | 26000 | 11 | 17.6 | 20 | 12.3 | 0.3 | 0.024 |
| 16000 | 24000 | 12 | 17.6 | 20 | 14.4 | 0.3 | 0.026 |
| 16000 | 24000 | 12 | 19.6 | 24 | 14.4 | 0.3 | 0.036 |
| 15000 | 23000 | 14 | 19.6 | 22 | 16.4 | 0.3 | 0.030 |
| 15000 | 23000 | 14 | 21.6 | 26 | 16.4 | 0.3 | 0.040 |
| 13000 | 20000 | 17 | 23.6 | 26 | 20.4 | 0.3 | 0.029 |
| 13000 | 20000 | 17 | 25.6 | 30 | 20.4 | 0.3 | 0.050 |
| 12000 | 18000 | 19 | 25.6 | 28 | 22.4 | 0.3 | 0.042 |
| 12000 | 18000 | 19 | 28.4 | 33 | 22.4 | 0.3 | 0.078 |
| 11000 | 16000 | 22 | 28.4 | 33 | 25.6 | 0.3 | 0.076 |
| 11000 | 16000 | 22 | 31.4 | 35 | 25.6 | 0.3 | 0.082 |
| 9000 | 13000 | 27 | 34.4 | 38 | 30.6 | 0.3 | 0.088 |
| 9000 | 13000 | 27 | 36.4 | 40 | 30.6 | 0.3 | 0.086 |
| 8500 | 13000 | 31 | 36.4 | 40 | 32.6 | 0.3 | 0.062 |
| 7500 | 11000 | 32 | 39.4 | 43 | 35.6 | 0.3 | 0.077 |
| 7500 | 11000 | 32 | 39.4 | 43 | 35.6 | 0.3 | 0.102 |
| 7500 | 11000 | 32 | 41.4 | 45 | 35.6 | 0.3 | 0.109 |
| 7500 | 11000 | 32 | 41.4 | 45 | 35.6 | 0.3 | 0.119 |
| 7000 | 11000 | 32 | 43.4 | 50 | 37.6 | 0.3 | 0.177 |
| 7000 | 11000 | 35 | 41.4 | 45 | 37.6 | 0.3 | 0.085 |
| 6500 | 10000 | 37 | 44.4 | 48 | 40.6 | 0.3 | 0.113 |
| 6500 | 10000 | 37 | 46.2 | 53 | 40.6 | 0.3 | 0.190 |
| 6000 | 9000 | 42 | 49.2 | 53 | 45.6 | 0.3 | 0.127 |
| 6000 | 9000 | 42 | 52.2 | 60 | 45.6 | 0.3 | 0.230 |
| 5500 | 9000 | 42 | 57.2 | 63 | 50.6 | 0.3 | 0.279 |
| 5500 | 8000 | 47 | 54.2 | 60 | 50.6 | 0.3 | 0.192 |
| 4800 | 7500 | 49 | 62.4 | 68 | 55.8 | 0.6 | 0.335 |
| 4800 | 7500 | 54 | 59.4 | 64 | 55.8 | 0.6 | 0.230 |
| 4400 | 6500 | 55 | 67.2 | 73 | 60.8 | 1.0 | 0.410 |
| 4100 | 6000 | 60 | 72.2 | 80 | 66.0 | 1.0 | 0.680 |

Machined-ring needle roller bearings, separable series **NAO**

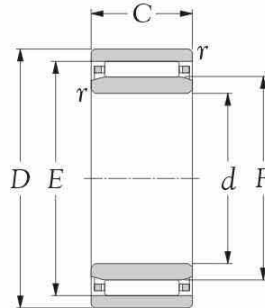

| Inner bore <i>d</i> mm | Bearing number | Boundary dimensions | | | | | Basic load ratings (Radial) | | | |
|------------------------------|----------------|---------------------|----------|--------------------------------|----------|----------|-----------------------------|---------------------------------|----------------------------|---------------------------------|
| | | <i>D</i> | <i>C</i> | $r \leq \text{min}^{1)}$ mm | <i>F</i> | <i>E</i> | dynamic <i>C</i> N | static <i>C</i> ₀ | dynamic <i>C</i> kgf | static <i>C</i> ₀ |
| 60 | NAO 60x90x30 | 90 | 30 | 1 | 70 | 78 | 65500 | 149000 | 6700 | 15200 |
| 65 | NAO 65x95x30 | 95 | 30 | 1 | 75 | 83 | 67500 | 157000 | 6850 | 16100 |
| 70 | NAO 70x95x30 | 95 | 30 | 1 | 80 | 86 | 57000 | 159000 | 5800 | 16200 |
| 70 | NAO 70x100x30 | 100 | 30 | 1 | 80 | 88 | 69000 | 166000 | 7050 | 17000 |
| 75 | NAO 75x105x25 | 105 | 25 | 1 | 85 | 93 | 61500 | 146000 | 6250 | 14900 |
| 75 | NAO 75x105x30 | 105 | 30 | 1 | 85 | 93 | 71000 | 175000 | 7200 | 17900 |
| 80 | NAO 80x110x30 | 110 | 30 | 1 | 90 | 98 | 72500 | 184000 | 7400 | 18800 |
| 85 | NAO 85x115x30 | 115 | 30 | 1 | 95 | 103 | 74000 | 193000 | 7550 | 19600 |
| 90 | NAO 90x120x30 | 120 | 30 | 1 | 100 | 108 | 76000 | 201000 | 7700 | 20500 |

Notes: 1) These values are the allowable minimum dimensions of the chamfer dimension r .

Machined-ring needle roller bearings, separable series NAO

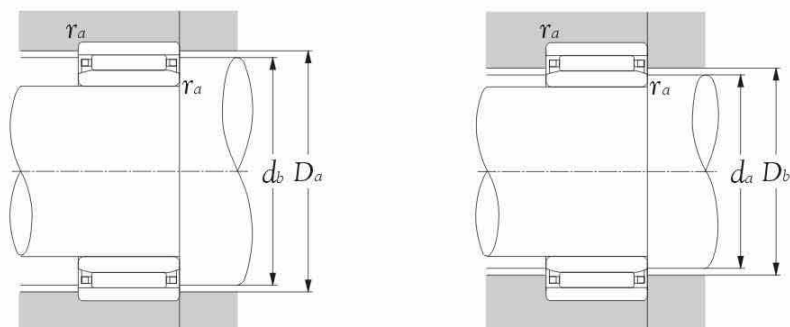

| Max runout speed | | Abutment dimensions | | | | | Weight |
|------------------|------|---------------------|-------|--------------|-------|--------------|---------|
| grease | oil | d_a mm | d_b | D_a max | D_b | r_a max | kg (s). |
| r/min | | | | | | | |
| 3800 | 5500 | 65 | 77.2 | 85 | 71.0 | 1.0 | 0.720 |
| 3600 | 5500 | 70 | 82.2 | 90 | 76.0 | 1.0 | 0.770 |
| 3300 | 5000 | 75 | 85.2 | 90 | 81.0 | 1.0 | 0.675 |
| 3300 | 5000 | 75 | 87.2 | 95 | 81.0 | 1.0 | 0.850 |
| 3100 | 4700 | 80 | 92.2 | 100 | 86.0 | 1.0 | 0.700 |
| 3100 | 4700 | 80 | 92.2 | 100 | 86.0 | 1.0 | 0.880 |
| 3000 | 4400 | 85 | 97.2 | 105 | 91.0 | 1.0 | 0.920 |
| 2800 | 4200 | 90 | 102.2 | 110 | 96.0 | 1.0 | 0.960 |
| 2700 | 4000 | 95 | 107.2 | 115 | 101.0 | 1.0 | 1.040 |



Thrust roller bearings

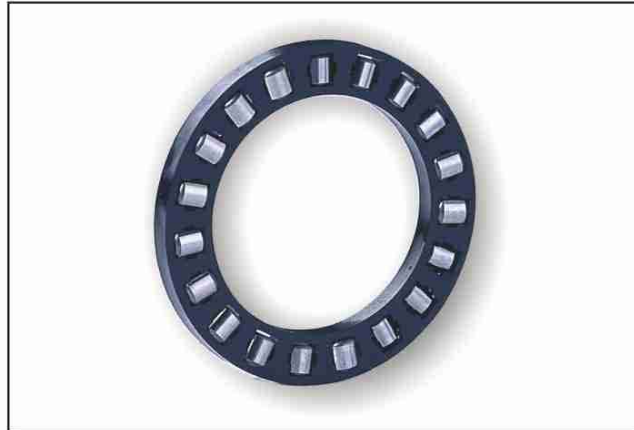

TECHNICAL SUPPLEMENT

T098 - 099

PRODUCT INFORMATION

P100 - 104



AXK11

P100 - 101



AS

P100 - 101



WS

P100 - 101



GS

P100 - 101



LS

P102



K 811, K 812

P103 - P104

1. Types and designs

KSM Roller and Cage Thrust Assemblies are available in the series AXK, which has needle rollers; and in series K 811, K 812, each of which incorporates cylindrical rollers. Each pocket of the series K 811 and K 812 has a single row of cylindrical rollers. Series AXK bearings, which have needle rollers, use a pressed-steel cage. Series K 811, and K 812 they can optionally employ a pressed-steel cage or a cage of molded polyamide reinforced with glass fiber or carbon fiber (suffix TV). The TV cage features a maximum allowable operating temperature of 120°C and maximum allowable continuous operating temperature of 100°C. The bearing washers for **KSM** Thrust Roller Bearings are available in an AS model made of surface-hardened 1 mm-thick steel plate, and in WS and GS models, which are machined types. The AS model can be used on either the shaft or housing side. This bearing washer, however, requires that the adjacent mechanical components have sufficient rigidity and good form accuracy. Before being mounted, the bearing washer may remain somewhat warped. This phenomenon should not be regarded as a problem because the warpage will be eliminated once a predetermined level of thrust load is exerted on the washer. The bore of the WS model is fitted to a shaft, and the outside surface of the GS model is fitted to a housing. Both models therefore provide the bearings with greater rigidity and higher running accuracy. Bearing models 811, 812 are formed by respectively combining the roller and cage thrust assemblies of models K 811 and K 812 with the associated model WS or GS bearing washer. They are standard series bearings whose dimension series, specified in ISO 104 (Boundary dimensions for rolling bearings), are 11, 12, and 93, respectively.



Fig. 1 Series AXK



Fig. 2 Series K 811, K 812



Fig. 3 Series AS



Fig. 4 Series WS

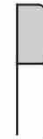
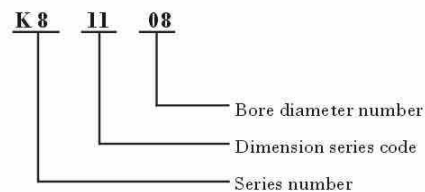
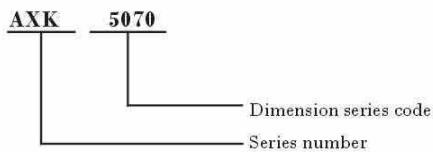

Fig. 5 Series GS

2. Interpreting bearing numbers

The bearing numbers of **KSM** Roller and Cage Thrust Assemblies, Bearing Rings, and Thrust Roller Bearings comprise a series number, dimension series code, bore diameter number, and suffix.

Roller and cage thrust assembly



Bearing washer

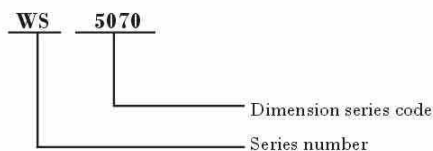

3. Bearing tolerance

The dimensional accuracy, form accuracy, and running accuracy of series 811, 812 thrust cylindrical roller bearings are given in "Bearing Tolerances". The bore (D_{el}) of roller and cage thrust assemblies (series AXK, K 811, K 812) is machined to a tolerance of E11 (or E12 for bearings having a suffix T2). The outside surface (D_c) of the series AXK is machined to a tolerance of c12, while those of the series K 811, K 812 are machined to a tolerance of a13.

4. Raceway surface requirements

When the shaft and housing are used as a raceway for a roller and cage thrust assembly, the raceway should satisfy the requirements in Table 1.

Table 1 Raceway requirements

| Characteristics | Requirement |
|-------------------|-------------|
| Squareness (max.) | IT6 (IT4) |
| Surface roughness | 0,4a |
| Surface hardness | HRC58~64 |

5. Bearing washer fits

The fits of the shafts and housing that mount the thrust bearing washers (AS, WS, and GS models) are given in Table 2 below.

Table 2 Raceway requirements

| Bearing washer | Shaft | Housing |
|----------------|-------|---------|
| Series AS | H10 | H11 |
| Series WS | h6 | — |
| Series GS | — | H7 |

Thrust needle roller bearings series AXK, AS, WS, GS

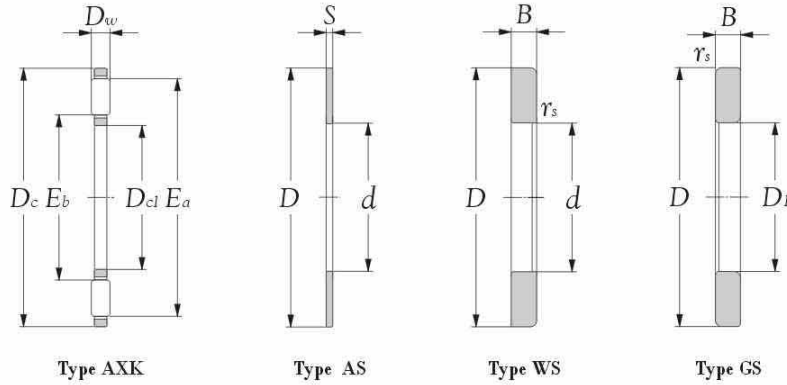

| Inner bore D_{cl} E11 mm | Bearing number | | | | Boundary dimensions (mm) | | | | | | | | | | |
|-------------------------------------|--|-----------|------------|------------|--------------------------|---------------------|--------------|-----------------|-------------------|-----|-----------------------|-----|-----------------------|-------------------------------------|-------------------------|
| | thrust needle roller and cage assembly (consistant with cylindrical) | Washer | Inner ring | Outer ring | D_c C12 | D_w 0 -0.01 | D_p e15 | D_{p1} E12 | $S^{2)}$ ±0.05 | d | d_1 -0.2 -0.5 | D | D_1 +0.5 +0.2 | B | r_s min ¹⁾ |
| 10 | AXK 1024 | AS 1024 | WS 1024 | GS 1024 | 24 | 2 | 24 | 10 | 1 | 10 | 24 | 24 | 10 | 2.75 ⁰ _{-0.060} | 0.3 |
| 12 | AXK 1226 | AS 1226 | WS 1226 | GS 1226 | 26 | 2 | 26 | 12 | 1 | 12 | 26 | 26 | 12 | 2.75 ⁰ _{-0.060} | 0.3 |
| 15 | AXK 1528 | AS 1528 | WS 1528 | GS 1528 | 28 | 2 | 28 | 15 | 1 | 15 | 28 | 28 | 16 | 2.75 ⁰ _{-0.060} | 0.3 |
| 17 | AXK 1730 | AS 1730 | WS 1730 | GS 1730 | 30 | 2 | 30 | 17 | 1 | 17 | 30 | 30 | 18 | 2.75 ⁰ _{-0.060} | 0.3 |
| 20 | AXK 2035 | AS 2035 | WS 2035 | GS 2035 | 35 | 2 | 35 | 20 | 1 | 20 | 35 | 35 | 21 | 2.75 ⁰ _{-0.060} | 0.3 |
| 25 | AXK 2542 | AS 2542 | WS 2542 | GS 2542 | 42 | 2 | 42 | 25 | 1 | 25 | 42 | 42 | 26 | 3.00 ⁰ _{-0.060} | 0.6 |
| 30 | AXK 3047 | AS 3047 | WS 3047 | GS 3047 | 47 | 2 | 47 | 30 | 1 | 30 | 47 | 47 | 32 | 3.00 ⁰ _{-0.060} | 0.6 |
| 35 | AXK 3552 | AS 3552 | WS 3552 | GS 3552 | 52 | 2 | 52 | 35 | 1 | 35 | 52 | 52 | 37 | 3.50 ⁰ _{-0.075} | 0.6 |
| 40 | AXK 4060 | AS 4060 | WS 4060 | GS 4060 | 60 | 3 | 60 | 40 | 1 | 40 | 60 | 60 | 42 | 3.50 ⁰ _{-0.075} | 0.6 |
| 45 | AXK 4565 | AS 4565 | WS 4565 | GS 4565 | 65 | 3 | 65 | 45 | 1 | 45 | 65 | 65 | 47 | 4.00 ⁰ _{-0.075} | 0.6 |
| 50 | AXK 5070 | AS 5070 | WS 5070 | GS 5070 | 70 | 3 | 70 | 50 | 1 | 50 | 70 | 70 | 52 | 4.00 ⁰ _{-0.075} | 0.6 |
| 55 | AXK 5578 | AS 5578 | WS 5578 | GS 5578 | 78 | 3 | 78 | 55 | 1 | 55 | 78 | 78 | 57 | 5.00 ⁰ _{-0.075} | 0.6 |
| 60 | AXK 6085 | AS 6085 | WS 6085 | GS 6085 | 85 | 3 | 85 | 60 | 1 | 60 | 85 | 85 | 62 | 4.75 ⁰ _{-0.075} | 1.0 |
| 65 | AXK 6590 | AS 6590 | WS 6590 | GS 6590 | 90 | 3 | 90 | 65 | 1 | 65 | 90 | 90 | 67 | 5.25 ⁰ _{-0.075} | 1.0 |
| 70 | AXK 7095 | AS 7095 | WS 7095 | GS 7095 | 95 | 4 | 95 | 70 | 1 | 70 | 95 | 95 | 72 | 5.25 ⁰ _{-0.075} | 1.0 |
| 75 | AXK 75100 | AS 75100 | WS 75100 | GS 75100 | 100 | 4 | 100 | 75 | 1 | 75 | 100 | 100 | 77 | 5.75 ⁰ _{-0.075} | 1.0 |
| 80 | AXK 80105 | AS 80105 | WS 80105 | GS 80105 | 105 | 4 | 105 | 80 | 1 | 80 | 105 | 105 | 82 | 5.75 ⁰ _{-0.075} | 1.0 |
| 85 | AXK 85110 | AS 85110 | WS 85110 | GS 85110 | 110 | 4 | 110 | 85 | 1 | 85 | 110 | 110 | 87 | 5.75 ⁰ _{-0.075} | 1.0 |
| 90 | AXK 90120 | AS 90120 | WS 90120 | GS 90120 | 120 | 4 | 120 | 90 | 1 | 90 | 120 | 120 | 92 | 6.50 ⁰ _{-0.090} | 1.0 |
| 100 | AXK 100135 | AS 100135 | WS 100135 | GS 100135 | 135 | 4 | 135 | 100 | 1 | 100 | 135 | 135 | 102 | 7.00 ⁰ _{-0.090} | 1.0 |
| 110 | AXK 110145 | AS 110145 | WS 110145 | GS 110145 | 145 | 4 | 145 | 110 | 1 | 110 | 145 | 145 | 112 | 7.00 ⁰ _{-0.090} | 1.0 |
| 120 | AXK 120155 | AS 120155 | WS 120155 | GS 120155 | 155 | 4 | 155 | 120 | 1 | 120 | 155 | 155 | 122 | 7.00 ⁰ _{-0.090} | 1.0 |
| 130 | AXK 130170 | AS 130170 | WS 130170 | GS 130170 | 170 | 5 | 170 | 130 | 1 | 130 | 170 | 170 | 132 | 9.00 ⁰ _{-0.090} | 1.0 |
| 140 | AXK 140180 | AS 140180 | WS 140180 | GS 140180 | 180 | 5 | 180 | 140 | 1 | 140 | 178 | 180 | 142 | 9.50 ⁰ _{-0.090} | 1.0 |
| 150 | AXK 150190 | AS 150190 | WS 150190 | GS 150190 | 190 | 5 | 190 | 150 | 1 | 150 | 188 | 190 | 152 | 9.50 ⁰ _{-0.090} | 1.0 |
| 160 | AXK 160200 | AS 160200 | WS 160200 | GS 160200 | 200 | 5 | 200 | 160 | 1 | 160 | 198 | 200 | 162 | 9.50 ⁰ _{-0.090} | 1.0 |

Notes: 1) These values are the allowable minimum dimensions of the chamfer dimension r_s .
2) Measured axial load is more than 20kgf.

Thrust needle roller bearings series AXK, AS, WS, GS

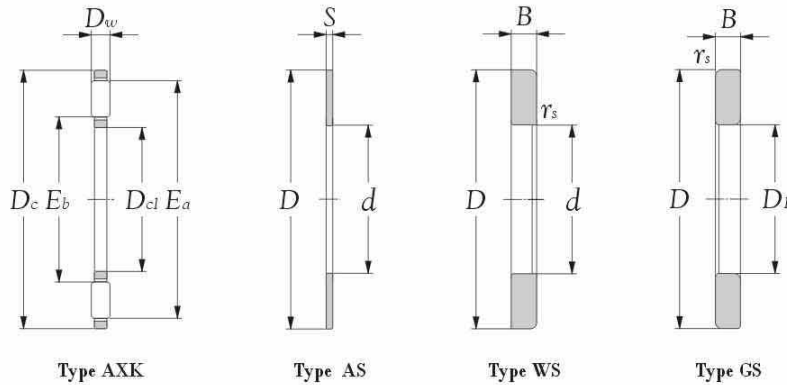

| dynamic C | Basic load ratings | | dynamic C | static Co | Max runout speed | | Reference dimensions | | Weight | | |
|--------------|--------------------|-------|--------------|--------------|------------------|-----|----------------------|--------|--------|-------|--------------|
| | static Co | kgf | | | grease | oil | Eb | Ea | AXK.. | AS.. | WS.. GS.. |
| N | | | | | r/min | | mm | | kg. | | |
| 9150 | 25300 | 935 | 2580 | 3500 | 14000 | 11 | 21 | 0.0028 | 0.0030 | 0.008 | |
| 9850 | 28900 | 1010 | 2940 | 3300 | 13000 | 13 | 23 | 0.0030 | 0.0033 | 0.009 | |
| 11300 | 36000 | 1150 | 3700 | 2800 | 11000 | 17 | 27 | 0.0035 | 0.0035 | 0.010 | |
| 11900 | 39500 | 1220 | 4050 | 2500 | 10000 | 19 | 29 | 0.0040 | 0.0038 | 0.011 | |
| 13200 | 46500 | 1340 | 4750 | 2100 | 8500 | 22 | 34 | 0.0050 | 0.0051 | 0.014 | |
| 14600 | 58000 | 1490 | 5900 | 1800 | 7000 | 29 | 41 | 0.0070 | 0.0070 | 0.021 | |
| 16300 | 69500 | 1660 | 7100 | 1500 | 6000 | 35 | 46 | 0.0080 | 0.0080 | 0.025 | |
| 17800 | 81500 | 1820 | 8300 | 1400 | 5500 | 40 | 51 | 0.0100 | 0.0091 | 0.033 | |
| 27400 | 110000 | 2790 | 11300 | 1200 | 4700 | 45 | 58 | 0.0185 | 0.0123 | 0.044 | |
| 29800 | 128000 | 3050 | 13100 | 1100 | 4300 | 50 | 63 | 0.0205 | 0.0136 | 0.055 | |
| 31500 | 143000 | 3250 | 14500 | 1000 | 3900 | 55 | 68 | 0.0235 | 0.0148 | 0.060 | |
| 38000 | 186000 | 3850 | 19000 | 900 | 3500 | 60 | 76 | 0.0308 | 0.0189 | 0.095 | |
| 44500 | 234000 | 4550 | 23900 | 800 | 3200 | 65 | 83 | 0.0390 | 0.0223 | 0.101 | |
| 46500 | 254000 | 4750 | 25900 | 750 | 3000 | 70 | 88 | 0.0400 | 0.0239 | 0.125 | |
| 53500 | 253000 | 5500 | 25800 | 750 | 2900 | 74 | 93 | 0.0600 | 0.0254 | 0.134 | |
| 55000 | 266000 | 5650 | 27100 | 700 | 2700 | 79 | 98 | 0.0610 | 0.0270 | 0.155 | |
| 56500 | 279000 | 5750 | 28400 | 650 | 2600 | 84 | 103 | 0.0630 | 0.0284 | 0.163 | |
| 57500 | 291000 | 5900 | 29700 | 600 | 2400 | 89 | 108 | 0.0668 | 0.0301 | 0.175 | |
| 71000 | 390000 | 7250 | 39500 | 600 | 2300 | 94 | 118 | 0.0860 | 0.0388 | 0.250 | |
| 90500 | 550000 | 9200 | 56500 | 500 | 2000 | 105 | 133 | 0.1120 | 0.0505 | 0.350 | |
| 93500 | 590000 | 9550 | 60500 | 480 | 1900 | 115 | 143 | 0.1220 | 0.0549 | 0.385 | |
| 99000 | 650000 | 10100 | 66500 | 430 | 1700 | 125 | 153 | 0.1310 | 0.0592 | 0.415 | |
| 140000 | 900000 | 14300 | 92000 | 400 | 1600 | 136 | 167 | 0.2050 | 0.0740 | 0.663 | |
| 145000 | 960000 | 14800 | 97500 | 380 | 1500 | 146 | 177 | 0.2190 | 0.0790 | 0.749 | |
| 149000 | 1020000 | 15200 | 104000 | 350 | 1400 | 156 | 187 | 0.2320 | 0.0840 | 0.796 | |
| 154000 | 1070000 | 15700 | 110000 | 330 | 1300 | 166 | 197 | 0.2460 | 0.0890 | 0.842 | |

Thrust needle roller bearings series LS

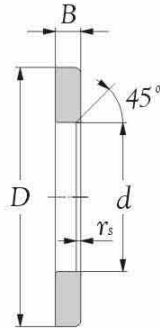

| Inner bore <i>d</i> mm | Bearing number | Boundary dimensions | | | Basic load ratings | | Limiting speed $n_{grease} \approx$ min^{-1} | Roll path size | |
|------------------------------|----------------|---------------------|----------------|-------------|--------------------------|---------------------------------|---|-----------------------|-----------------------|
| | | <i>D</i> | <i>B</i> mm | r_s mm | dynamic <i>C</i> N | static <i>C</i> ₀ | | <i>E</i> _b | <i>E</i> _a |
| 6 | LS 0619 | 19 | 2.75 | 0.3 | 6800 | 15500 | 16000 | 7 | 18 |
| 8 | LS 0821 | 21 | 2.75 | 0.3 | 7800 | 19400 | 15000 | 9 | 20 |
| 10 | LS 1024 | 24 | 2.75 | 0.3 | 9200 | 25500 | 14000 | 12 | 23 |
| 12 | LS 1226 | 26 | 2.75 | 0.3 | 9900 | 29000 | 13000 | 14 | 25 |
| 15 | LS 1528 | 28 | 2.75 | 0.3 | 11300 | 36000 | 11000 | 17 | 27 |
| 17 | LS 1730 | 30 | 2.75 | 0.3 | 11900 | 39500 | 10000 | 19 | 29 |
| 20 | LS 2035 | 35 | 2.75 | 0.3 | 13100 | 46500 | 8500 | 22 | 34 |
| 25 | LS 2542 | 42 | 3.00 | 0.6 | 14700 | 58000 | 7000 | 29 | 41 |
| 30 | LS 3047 | 47 | 3.00 | 0.6 | 16300 | 70000 | 6000 | 34 | 46 |
| 35 | LS 3552 | 52 | 3.50 | 0.6 | 17800 | 81000 | 5500 | 39 | 51 |
| 40 | LS 4060 | 60 | 3.50 | 0.6 | 28000 | 114000 | 4700 | 45 | 58 |
| 45 | LS 4565 | 65 | 4.00 | 0.6 | 30000 | 128000 | 4300 | 50 | 63 |
| 50 | LS 5070 | 70 | 4.00 | 0.6 | 32000 | 143000 | 3900 | 55 | 68 |
| 55 | LS 5578 | 78 | 5.00 | 0.6 | 38000 | 186000 | 3500 | 60 | 76 |
| 60 | LS 6085 | 85 | 4.75 | 1.0 | 44500 | 234000 | 3200 | 65 | 83 |
| 65 | LS 6590 | 90 | 5.25 | 1.0 | 46500 | 255000 | 3000 | 70 | 88 |
| 70 | LS 7095 | 95 | 5.25 | 1.0 | 54000 | 255000 | 2900 | 74 | 93 |
| 75 | LS 75100 | 100 | 5.75 | 1.0 | 55000 | 265000 | 2700 | 79 | 98 |
| 80 | LS 80105 | 105 | 5.75 | 1.0 | 56000 | 280000 | 2600 | 84 | 103 |
| 85 | LS 85110 | 110 | 5.75 | 1.0 | 58000 | 290000 | 2400 | 89 | 108 |
| 90 | LS 90120 | 120 | 6.50 | 1.0 | 73000 | 405000 | 2300 | 94 | 118 |
| 100 | LS 100135 | 135 | 7.00 | 1.0 | 91000 | 560000 | 2000 | 105 | 133 |
| 110 | LS 110145 | 145 | 7.00 | 1.0 | 97000 | 620000 | 1900 | 115 | 143 |

Thrust needle roller bearings series K 811

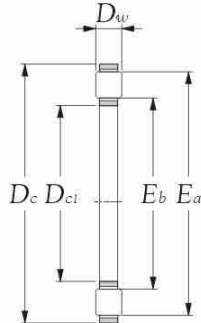

| Inner bore D_{ci} E11 mm | Bearing number thrust needle roller and cage assembly | Boundary dimensions (mm) | | Basic load ratings | | | | Max runout speed | | Reference dimensions | | Weight kg. |
|-------------------------------------|---|--------------------------|--------------------|--------------------|--------|----------|-------|------------------|-------|----------------------|-------|---------------|
| | | D_c C12 | D_w 0 0.01 | C N | C_o | C kgf | C_o | grease r/min | oil | E_b | E_a | |
| 10 | K 81100 | 24 | 3.5 | 10800 | 21500 | 1110 | 2190 | 3400 | 13000 | 12 | 23 | 0.0035 |
| 12 | K 81101 | 26 | 3.5 | 11500 | 23900 | 1170 | 2430 | 3000 | 12000 | 14 | 25 | 0.0040 |
| 15 | K 81102 | 28 | 3.5 | 12900 | 28600 | 1310 | 2920 | 2800 | 11000 | 16 | 27 | 0.0060 |
| 17 | K 81103 | 30 | 3.5 | 13400 | 31000 | 1370 | 3150 | 2500 | 10000 | 18 | 29 | 0.0080 |
| 20 | K 81104 | 35 | 4.5 | 20200 | 46500 | 2060 | 4700 | 2100 | 8500 | 21 | 34 | 0.0120 |
| 25 | K 81105 | 42 | 5.0 | 27300 | 68000 | 2780 | 6900 | 1800 | 7000 | 27 | 40 | 0.0180 |
| 30 | K 81106 | 47 | 5.0 | 27800 | 72500 | 2840 | 7400 | 1500 | 6000 | 32 | 45 | 0.0200 |
| 35 | K 81107 | 52 | 5.0 | 31000 | 87000 | 3150 | 8900 | 1400 | 5500 | 37 | 50 | 0.0240 |
| 40 | K 81108 | 60 | 6.0 | 43000 | 121000 | 4350 | 12400 | 1200 | 4800 | 42 | 58 | 0.0350 |
| 45 | K 81109 | 65 | 6.0 | 45500 | 135000 | 4650 | 13800 | 1100 | 4400 | 47 | 63 | 0.0400 |
| 50 | K 81110 | 70 | 6.0 | 48000 | 150000 | 4900 | 15300 | 1000 | 4000 | 52 | 68 | 0.0450 |
| 55 | K 81111 | 78 | 6.0 | 62500 | 215000 | 6350 | 21900 | 900 | 3600 | 57 | 76 | 0.0600 |
| 60 | K 81112 | 85 | 7.5 | 69000 | 215000 | 7000 | 21900 | 830 | 3300 | 63 | 82 | 0.0830 |
| 65 | K 81113 | 90 | 7.5 | 73000 | 236000 | 7400 | 24100 | 780 | 3100 | 68 | 87 | 0.0900 |
| 70 | K 81114 | 95 | 7.5 | 76500 | 257000 | 7800 | 26200 | 730 | 2900 | 73 | 92 | 0.0970 |
| 75 | K 81115 | 100 | 7.5 | 78000 | 268000 | 7950 | 27300 | 680 | 2700 | 78 | 97 | 0.1150 |
| 80 | K 81116 | 105 | 7.5 | 79500 | 279000 | 8100 | 28400 | 650 | 2600 | 83 | 102 | 0.1190 |
| 85 | K 81117 | 110 | 7.5 | 83000 | 300000 | 8450 | 30500 | 630 | 2500 | 88 | 107 | 0.1250 |
| 90 | K 81118 | 120 | 9.0 | 112000 | 395000 | 11400 | 40500 | 580 | 2300 | 93 | 117 | 0.1700 |

Notes: 1) The dimensional tolerance for a bearing with a T2 suffix is E12.

Thrust needle roller bearings series K 812

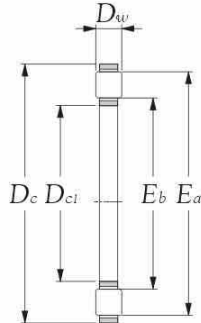

| Inner bore D_{ci} E11 mm | Bearing number thrust needle roller and cage assembly | Boundary dimensions (mm) | | Basic load ratings | | | | Max runout speed | | Reference dimensions | | Weight kg. |
|-------------------------------------|---|--------------------------|--------------------|--------------------|--------|----------|-------|------------------|------|----------------------|-------|---------------|
| | | D_c C12 | D_w 0 0.01 | C N | C_o | C kgf | C_o | grease r/min | oil | E_b | E_a | |
| 30 | K 81206 | 52 | 7.5 | 53500 | 129000 | 5450 | 13100 | 1500 | 6000 | 32 | 50 | 0.050 |
| 35 | K 81207 | 62 | 7.5 | 54500 | 139000 | 5550 | 14200 | 1200 | 4900 | 37 | 60 | 0.065 |
| 40 | K 81208 | 68 | 9.0 | 74500 | 190000 | 7600 | 19400 | 1100 | 4400 | 43 | 66 | 0.085 |
| 45 | K 81209 | 73 | 9.0 | 82000 | 222000 | 8350 | 22600 | 1000 | 4100 | 48 | 71 | 0.100 |
| 50 | K 81210 | 78 | 9.0 | 85000 | 238000 | 8650 | 24200 | 950 | 3800 | 53 | 76 | 0.105 |
| 55 | K 81211 | 90 | 11.0 | 121000 | 340000 | 12300 | 34500 | 830 | 3300 | 58 | 87 | 0.190 |
| 60 | K 81212 | 95 | 11.0 | 125000 | 365000 | 12800 | 37000 | 780 | 3100 | 64 | 92 | 0.200 |
| 65 | K 81213 | 100 | 11.0 | 130000 | 385000 | 13200 | 39500 | 730 | 2900 | 69 | 97 | 0.215 |
| 70 | K 81214 | 105 | 11.0 | 134000 | 410000 | 13700 | 42000 | 680 | 2700 | 74 | 102 | 0.225 |
| 75 | K 81215 | 110 | 11.0 | 138000 | 435000 | 14100 | 44500 | 650 | 2600 | 79 | 107 | 0.240 |
| 80 | K 81216 | 115 | 11.0 | 142000 | 460000 | 14500 | 47000 | 630 | 2500 | 84 | 112 | 0.250 |

Notes: 1) The dimensional tolerance for a bearing with a T2 suffix is E12.



Complex bearings



TECHNICAL SUPPLEMENT

T106 - 107

PRODUCT INFORMATION

P108 - 115

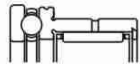

NKX, NKX..Z

P108 - 109

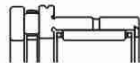

NKXR, NKXR..Z

P110 - 111

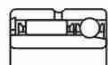

NKIA 59

P112 - 113

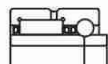

NKIB 59

P114 - 115

1. Bearing materials

Depending on the thrust bearing type that is combined with a radial needle roller bearing, **KSM** Complex Bearings can be categorized as thrust ball bearings (series NKX), thrust cylindrical roller bearings (series NKXR). The series NKX and NKXR complex bearings can carry a relatively large axial load in one direction and can be axially located.

When used in opposing pairs, they can bear an axial load in both directions and can be axially located. However, because they cannot accommodate a greater axial expansion, they should be mounted on a shorter shaft whose axial expansion is small. The variant with a dust-proofing cover on its thrust bearing (suffix Z) is easily handled because the thrust bearing is a non-separable type. This arrangement can also prevent splashing of the grease within the thrust bearing.

Generally, radial needle roller bearings in these complex bearings use a shaft as a raceway surface, without using an inner ring. However, they can incorporate an inner ring when a shaft is inappropriate as a raceway surface.

The tolerance class of the inscribed enveloping circle diameter (F_w) with needle roller bearings is class F6, the same as with machined ring needle roller bearings.

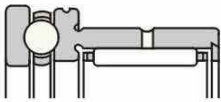

Fig. 1 Series NKX

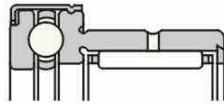

Fig. 2 Series NKX..Z

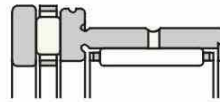

Fig. 3 Series NKXR

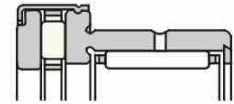

Fig. 4 Series NKXR..Z

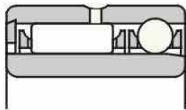

Fig. 5 Series NKIA

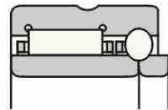
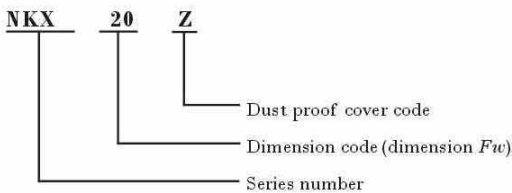

Fig. 6 Series NKIB

2. Interpreting bearing numbers

The bearing numbers of **KSM** Complex Bearings comprise a series number, dimension series code, Dimension code, and suffix.

Series NKX, NKXR



Series NKIA, NKIB

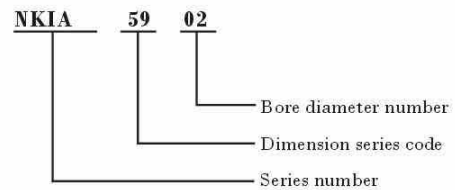

3. Bearing fits

Table 1 summarizes the fits of radial needle roller bearings to a shaft and housing. The thrust bearing washers of series NKX and NKXR bearings are installed in a housing whose bore diameter is at least 0.5 mm larger than the outside diameter D_1 or D_2 of the bearing washer.

Table 1 Fit to shaft and housing

| Bearing number | Shaft | Housing |
|-------------------|-------|---------|
| Series NKX, NKXR | k5 | K6(M6) |
| Series NKIA, NKIB | k5 | M6 |

Remarks: Fits appearing in parentheses are for applications requiring greater rigidity.

4. Rating life calculation

The rating life (L) of a complex bearings can be determined by inputting the results of the following calculations into the formula below:
 Calculate the rating life (L_r) of the radial needle roller bearing according to the working radial load.
 Calculate the rating life (L_a) of the thrust bearing according to the working axial load.

$$L = \frac{1}{\left(\frac{1}{L_r^{1.1}} + \frac{1}{L_a^{1.1}}\right)^{0.91}} \dots\dots\dots(1)$$

Needle roller bearings with thrust ball bearings series NKX, NKX..Z

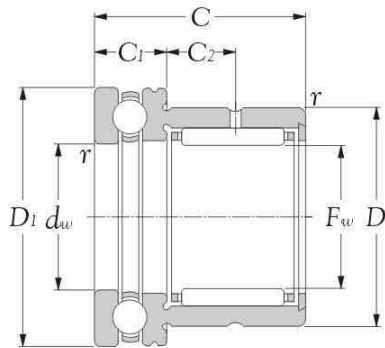

Type NKX
(Open type)

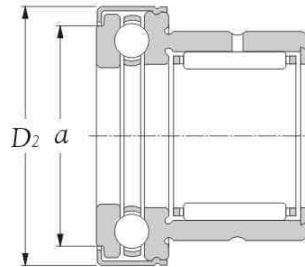

Type NKX..Z
(With cover)

| Inner bore F_w mm | Bearing number | | Boundary dimensions (mm) | | | | | | | | | Basic load ratings (Radial) | | | |
|---|----------------|----------|---|-----|-------|-------|---|---|-------|------|----------------------|-----------------------------|-----------------|--------------|-----------------|
| | | | d_w | D | D_1 | D_2 | C ₀ ⁰ -0.25 | C_1 ₀ ⁰ -0.20 | C_2 | a | r mm ¹⁾ | dynamic C | static C_o | dynamic C | static C_o |
| | | | | | | | | | | | N | | kgf | | |
| 10 ^{+0.022} _{+0.018} | NKX 10 | NKX 10 Z | 10 ^{+0.040} _{+0.025} | 19 | 24 | 25.0 | 23 | 9 | 6.5 | 19.7 | 0.3 | 5450 | 6450 | 555 | 660 |
| 12 ^{+0.027} _{+0.016} | NKX 12 | NKX 12 Z | 12 ^{+0.050} _{+0.032} | 21 | 26 | 27.0 | 23 | 9 | 6.5 | 21.7 | 0.3 | 6000 | 7700 | 615 | 785 |
| 15 ^{+0.027} _{+0.016} | NKX 15 | NKX 15 Z | 15 ^{+0.050} _{+0.032} | 24 | 28 | 29.0 | 23 | 9 | 6.5 | 23.7 | 0.3 | 8250 | 10200 | 840 | 1040 |
| 17 ^{+0.027} _{+0.016} | NKX 17 | NKX 17 Z | 17 ^{+0.050} _{+0.032} | 26 | 30 | 31.0 | 25 | 9 | 8.0 | 25.7 | 0.3 | 10400 | 14400 | 1060 | 1460 |
| 20 ^{+0.038} _{+0.020} | NKX 20 | NKX 20 Z | 20 ^{+0.061} _{+0.040} | 30 | 35 | 36.0 | 30 | 10 | 10.5 | 30.7 | 0.3 | 16400 | 27100 | 1670 | 2760 |
| 25 ^{+0.038} _{+0.020} | NKX 25 | NKX 25 Z | 25 ^{+0.061} _{+0.040} | 37 | 42 | 43.0 | 30 | 11 | 9.5 | 37.7 | 0.6 | 14200 | 24000 | 1450 | 2450 |
| 30 ^{+0.038} _{+0.020} | NKX 30 | NKX 30 Z | 30 ^{+0.061} _{+0.040} | 42 | 47 | 48.0 | 30 | 11 | 9.5 | 42.7 | 0.6 | 22300 | 39500 | 2280 | 4000 |
| 35 ^{+0.041} _{+0.025} | NKX 35 | NKX 35 Z | 35 ^{+0.075} _{+0.050} | 47 | 52 | 53.0 | 30 | 12 | 9.0 | 47.7 | 0.6 | 20000 | 36000 | 2040 | 3650 |
| 40 ^{+0.041} _{+0.025} | NKX 40 | NKX 40 Z | 40 ^{+0.075} _{+0.050} | 52 | 60 | 61.0 | 32 | 13 | 10.0 | 55.7 | 0.6 | 25900 | 52500 | 2650 | 5350 |
| 45 ^{+0.041} _{+0.025} | NKX 45 | NKX 45 Z | 45 ^{+0.075} _{+0.050} | 58 | 65 | 66.5 | 32 | 14 | 9.0 | 60.5 | 0.6 | 27600 | 59000 | 2810 | 6000 |
| 50 ^{+0.041} _{+0.025} | NKX 50 | NKX 50 Z | 50 ^{+0.075} _{+0.050} | 62 | 70 | 71.5 | 35 | 14 | 10.0 | 65.5 | 0.6 | 27900 | 62000 | 2850 | 6300 |
| 60 ^{+0.049} _{+0.030} | NKX 60 | NKX 60 Z | 60 ^{+0.090} _{+0.060} | 72 | 85 | 86.5 | 40 | 17 | 12.0 | 80.5 | 1.0 | 29800 | 71500 | 3050 | 7300 |
| 70 ^{+0.049} _{+0.030} | NKX 70 | NKX 70 Z | 70 ^{+0.090} _{+0.060} | 85 | 95 | 96.5 | 40 | 18 | 11.0 | 90.5 | 1.0 | 36500 | 86000 | 3700 | 8750 |

Notes: 1) These values are the allowable minimum dimensions of the chamfer dimension r .

Needle roller bearings with thrust ball bearings series **NKX, NKX..Z**

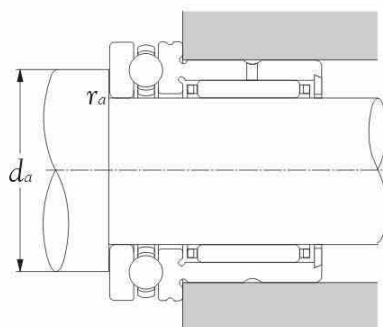

| dynamic C | Basic load ratings (Axial) | | dynamic C | static C ₀ | Max runout speed | | Abutment dimensions | | Weight kg. | |
|--------------|----------------------------|------|--------------|--------------------------|------------------|-----|---------------------|-------------|---------------|-------------|
| | static C ₀ | kgf | | | grease | oil | d_a mm | $r_{a\max}$ | Type NKX | Type NKX..Z |
| N | | | | | r/min | | | | | |
| 10000 | 14000 | 1020 | 1420 | 6700 | 9500 | 18 | 0.3 | 0.037 | 0.039 | |
| 10300 | 15400 | 1050 | 1570 | 6400 | 9200 | 20 | 0.3 | 0.042 | 0.044 | |
| 10500 | 16800 | 1070 | 1710 | 6200 | 8800 | 23 | 0.3 | 0.044 | 0.048 | |
| 10800 | 18200 | 1100 | 1850 | 6000 | 8500 | 25 | 0.3 | 0.051 | 0.056 | |
| 14200 | 24700 | 1450 | 2520 | 5200 | 7500 | 29 | 0.3 | 0.085 | 0.090 | |
| 19600 | 37000 | 1990 | 3800 | 4600 | 6500 | 35 | 0.6 | 0.125 | 0.132 | |
| 20400 | 42000 | 2080 | 4300 | 4300 | 6200 | 40 | 0.6 | 0.140 | 0.148 | |
| 20400 | 44500 | 2080 | 4550 | 3900 | 5600 | 45 | 0.6 | 0.167 | 0.175 | |
| 26900 | 63000 | 2740 | 6400 | 3500 | 5000 | 52 | 0.6 | 0.216 | 0.225 | |
| 27900 | 69000 | 2840 | 7050 | 3200 | 4600 | 57 | 0.6 | 0.252 | 0.265 | |
| 28800 | 75500 | 2930 | 7700 | 3100 | 4500 | 62 | 0.6 | 0.302 | 0.318 | |
| 41500 | 113000 | 4200 | 11500 | 2600 | 3700 | 75 | 1.0 | 0.465 | 0.484 | |
| 43000 | 127000 | 4400 | 12900 | 2400 | 3400 | 85 | 1.0 | 0.612 | 0.635 | |



Needle roller bearings with thrust cylindrical roller bearings series NKXR, NKXR..Z

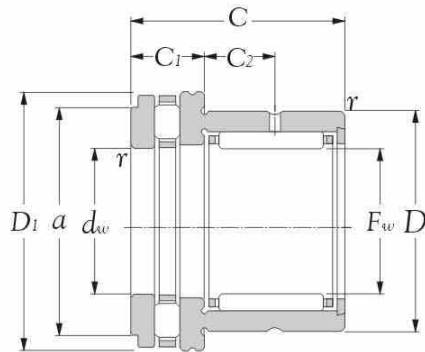

Type NKXR
(Open type)

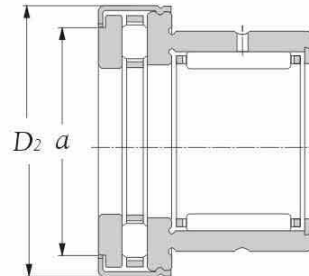

Type NKXR..Z
(With cover)

| Inner bore F_w mm | Bearing number | | Boundary dimensions (mm) | | | | | | | | Basic load ratings (Radial) | | | | |
|---|----------------|-----------|---|-----|-------|-------|-------------------------------|---------------------------------|-------|------|-----------------------------|--------------|----------------------|--------------|------------------------|
| | | | d_w | D | D_1 | D_2 | C _{0 -0.25} | C_1 _{0 -0.20} | C_2 | a | r mm ¹⁾ | dynamic C | static C_o N | dynamic C | static C_o kgf |
| 15 ^{+0.027} _{+0.016} | NKXR 15 | NKXR 15 Z | 15 ^{+0.050} _{+0.032} | 24 | 28 | 29.0 | 23 | 9 | 6.5 | 23.7 | 0.3 | 8250 | 10200 | 840 | 1040 |
| 17 ^{+0.027} _{+0.016} | NKXR 17 | NKXR 17 Z | 17 ^{+0.050} _{+0.032} | 26 | 30 | 31.0 | 25 | 9 | 8.0 | 25.7 | 0.3 | 10400 | 14400 | 1060 | 1460 |
| 20 ^{+0.038} _{+0.020} | NKXR 20 | NKXR 20 Z | 20 ^{+0.061} _{+0.040} | 30 | 35 | 36.0 | 30 | 10 | 10.5 | 30.7 | 0.3 | 16400 | 27100 | 1670 | 2760 |
| 25 ^{+0.038} _{+0.020} | NKXR 25 | NKXR 25 Z | 25 ^{+0.061} _{+0.040} | 37 | 42 | 43.0 | 30 | 11 | 9.5 | 37.7 | 0.6 | 14200 | 24000 | 1450 | 2450 |
| 30 ^{+0.038} _{+0.020} | NKXR 30 | NKXR 30 Z | 30 ^{+0.061} _{+0.040} | 42 | 47 | 48.0 | 30 | 11 | 9.5 | 42.7 | 0.6 | 22300 | 39500 | 2280 | 4000 |
| 35 ^{+0.041} _{+0.025} | NKXR 35 | NKXR 35 Z | 35 ^{+0.075} _{+0.050} | 47 | 52 | 53.0 | 30 | 12 | 9.0 | 47.7 | 0.6 | 20000 | 36000 | 2040 | 3650 |
| 40 ^{+0.041} _{+0.025} | NKXR 40 | NKXR 40 Z | 40 ^{+0.075} _{+0.050} | 52 | 60 | 61.0 | 32 | 13 | 10.0 | 55.7 | 0.6 | 25900 | 52500 | 2650 | 5350 |
| 45 ^{+0.041} _{+0.025} | NKXR 45 | NKXR 45 Z | 45 ^{+0.075} _{+0.050} | 58 | 65 | 66.5 | 32 | 14 | 9.0 | 60.5 | 0.6 | 27600 | 59000 | 2810 | 6000 |
| 50 ^{+0.041} _{+0.025} | NKXR 50 | NKXR 50 Z | 50 ^{+0.075} _{+0.050} | 62 | 70 | 71.5 | 35 | 14 | 10.0 | 65.5 | 0.6 | 27900 | 62000 | 2850 | 6300 |

Notes: 1) These values are the allowable minimum dimensions of the chamfer dimension r .

**Needle roller bearings with thrust cylindrical roller bearings
series NKXR, NKXR..Z**

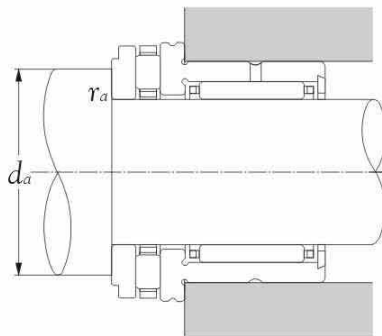

| dynamic C | Basic load ratings (Axial) | | dynamic C | static Co | Max runout speed | | Abutment dimensions | | Weight kg. | |
|--------------|----------------------------|--------------|--------------|--------------|------------------|-------|---------------------|-------------|---------------|--------------|
| | static Co | dynamic C | | | grease | oil | d_a mm | $r_{a\max}$ | Type NKXR | Type NKXR..Z |
| N | | kgf | | | r/min | | | | | |
| 12900 | 28600 | 1310 | 2920 | | 2800 | 11000 | 25 | 0.3 | 0.048 | 0.052 |
| 13400 | 31000 | 1370 | 3150 | | 2500 | 10000 | 27 | 0.3 | 0.050 | 0.053 |
| 20200 | 46500 | 2060 | 4700 | | 2100 | 8500 | 32 | 0.3 | 0.090 | 0.095 |
| 27300 | 68000 | 2780 | 6900 | | 1800 | 7000 | 39 | 0.6 | 0.128 | 0.135 |
| 27800 | 72500 | 2840 | 7400 | | 1500 | 6000 | 44 | 0.6 | 0.162 | 0.169 |
| 31000 | 87000 | 3150 | 8900 | | 1400 | 5500 | 49 | 0.6 | 0.184 | 0.195 |
| 43000 | 121000 | 4350 | 12400 | | 1200 | 4800 | 56 | 0.6 | 0.226 | 0.237 |
| 45500 | 135000 | 4650 | 13800 | | 1100 | 4400 | 61 | 0.6 | 0.267 | 0.286 |
| 48000 | 150000 | 4900 | 15300 | | 1000 | 4000 | 66 | 0.6 | 0.309 | 0.329 |



Needle roller bearings with angular contact ball bearings series NKIA 59

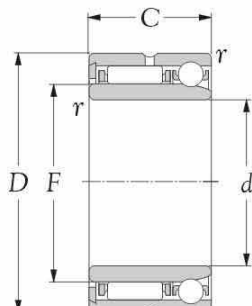

| Inner bore <i>d</i> mm | Bearing number | Boundary dimensions | | | | Basic load ratings (Radial) | | | |
|------------------------------|----------------|---------------------|----------|----------|------------------------------------|-----------------------------|---------------------------------|----------------------------|---------------------------------|
| | | <i>D</i> | <i>C</i> | <i>F</i> | <i>r</i> s <i>mm</i> ¹⁾ | dynamic <i>C</i> N | static <i>C</i> ₀ | dynamic <i>C</i> kgf | static <i>C</i> ₀ |
| 15 | NKIA 5902 | 28 | 18 | 20 | 0.3 | 9500 | 13400 | 970 | 1370 |
| 17 | NKIA 5903 | 30 | 18 | 22 | 0.3 | 10100 | 14900 | 1030 | 1520 |
| 20 | NKIA 5904 | 37 | 23 | 25 | 0.3 | 16500 | 22100 | 1680 | 2250 |
| 22 | NKIA 59/22 | 39 | 23 | 28 | 0.3 | 17500 | 24800 | 1790 | 2530 |
| 25 | NKIA 5905 | 42 | 23 | 30 | 0.3 | 17400 | 25000 | 1770 | 2550 |
| 30 | NKIA 5906 | 47 | 23 | 35 | 0.3 | 19400 | 30500 | 1980 | 3100 |
| 35 | NKIA 5907 | 55 | 27 | 42 | 0.6 | 25700 | 46000 | 2630 | 4700 |
| 40 | NKIA 5908 | 62 | 30 | 48 | 0.6 | 31000 | 61000 | 3150 | 6250 |
| 45 | NKIA 5909 | 68 | 30 | 55 | 0.6 | 33000 | 69500 | 3350 | 7100 |
| 50 | NKIA 5910 | 72 | 30 | 60 | 0.6 | 33500 | 73500 | 3450 | 7500 |
| 55 | NKIA 5911 | 80 | 34 | 63 | 1.0 | 44500 | 95500 | 4500 | 9700 |
| 60 | NKIA 5912 | 85 | 34 | 68 | 1.0 | 45500 | 101000 | 4600 | 10300 |
| 65 | NKIA 5913 | 90 | 34 | 75 | 1.0 | 46000 | 106000 | 4700 | 10800 |
| 70 | NKIA 5914 | 100 | 40 | 80 | 1.0 | 62500 | 146000 | 6350 | 14900 |

Notes: 1) These values are the allowable minimum dimensions of the chamfer dimension r .

Needle roller bearings with angular contact ball bearings series NKIA 59

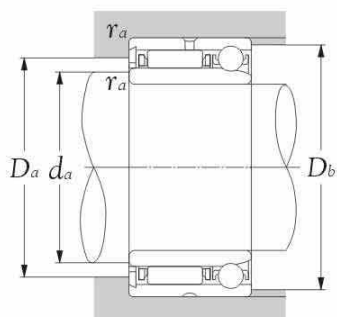

| dynamic C | Basic load ratings (Axial) | | | | Max runout speed | | Abutment dimensions | | | | Weight kg(s). |
|--------------|----------------------------|--------------|--------------------------|--------------|------------------|------|---------------------|---------------------|---------------------|------------------------|------------------|
| | static C ₀ | dynamic C | static C ₀ | dynamic C | grease | oil | d_a <i>mm</i> | D_a <i>max</i> | D_b <i>max</i> | r_{as} <i>max</i> | |
| | kgf | | | | r/min | | | | | | |
| 2340 | 3050 | 239 | 310 | 13000 | 20000 | 17.5 | 22.0 | 25.5 | 0.3 | 0.050 | |
| 2530 | 3550 | 258 | 360 | 12000 | 18000 | 19.5 | 24.0 | 27.5 | 0.3 | 0.056 | |
| 4700 | 6150 | 480 | 625 | 11000 | 16000 | 22.5 | 28.0 | 34.5 | 0.3 | 0.111 | |
| 4900 | 6750 | 500 | 690 | 9500 | 14000 | 24.5 | 31.0 | 36.5 | 0.3 | 0.120 | |
| 5100 | 7350 | 520 | 750 | 8500 | 13000 | 27.5 | 33.0 | 39.5 | 0.3 | 0.130 | |
| 5400 | 8550 | 550 | 870 | 7500 | 11000 | 32.5 | 38.0 | 44.5 | 0.3 | 0.147 | |
| 7400 | 12300 | 755 | 1260 | 6500 | 9500 | 40.0 | 45.0 | 50.0 | 0.6 | 0.243 | |
| 7750 | 14000 | 790 | 1430 | 5500 | 8500 | 45.0 | 51.0 | 57.0 | 0.6 | 0.347 | |
| 8500 | 17100 | 870 | 1740 | 5000 | 7500 | 50.0 | 58.0 | 63.0 | 0.6 | 0.401 | |
| 8800 | 18700 | 900 | 1910 | 4300 | 6500 | 55.0 | 63.0 | 67.0 | 0.6 | 0.410 | |
| 14300 | 33000 | 1460 | 3350 | 4300 | 6500 | 61.0 | 66.5 | 74.0 | 1.0 | 0.590 | |
| 14800 | 36000 | 1510 | 3650 | 4000 | 6000 | 66.0 | 71.5 | 79.0 | 1.0 | 0.632 | |
| 15200 | 39000 | 1550 | 4000 | 3700 | 5500 | 71.0 | 78.5 | 84.0 | 1.0 | 0.708 | |
| 18600 | 47500 | 1890 | 4850 | 3300 | 5000 | 76.0 | 84.0 | 94.0 | 1.0 | 1.050 | |

Needle roller bearings with three-point contact ball bearings series **NKIB 59**

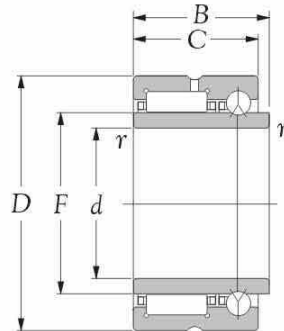

| Inner bore <i>d</i> mm | Bearing number | Boundary dimensions | | | | | Basic load ratings (Radial) | | | |
|------------------------------|----------------|---------------------|----------|----------|----------|---------------------------|-----------------------------|---------------------------------|----------------------------|---------------------------------|
| | | <i>D</i> | <i>B</i> | <i>C</i> | <i>F</i> | <i>r</i> mm ¹⁾ | dynamic <i>C</i> N | static <i>C</i> ₀ | dynamic <i>C</i> kgf | static <i>C</i> ₀ |
| 15 | NKIB 5902 | 28 | 20 | 18 | 20 | 0.3 | 10800 | 13600 | 1100 | 1390 |
| 17 | NKIB 5903 | 30 | 20 | 18 | 22 | 0.3 | 11200 | 14600 | 1140 | 1490 |
| 20 | NKIB 5904 | 37 | 25 | 23 | 25 | 0.3 | 21300 | 25500 | 2170 | 2600 |
| 22 | NKIB 59/22 | 39 | 25 | 23 | 28 | 0.3 | 23200 | 29300 | 2360 | 2990 |
| 25 | NKIB 5905 | 42 | 25 | 23 | 30 | 0.3 | 24000 | 31500 | 2450 | 3200 |
| 30 | NKIB 5906 | 47 | 25 | 23 | 35 | 0.3 | 25500 | 35500 | 2600 | 3600 |
| 35 | NKIB 5907 | 55 | 30 | 42 | 42 | 0.6 | 32000 | 50000 | 3300 | 5100 |
| 40 | NKIB 5908 | 62 | 34 | 48 | 28 | 0.6 | 43500 | 66500 | 4450 | 6800 |
| 45 | NKIB 5909 | 68 | 34 | 52 | 52 | 0.6 | 46000 | 73000 | 4700 | 7450 |
| 50 | NKIB 5910 | 72 | 34 | 58 | 58 | 0.6 | 48000 | 80000 | 4900 | 8150 |
| 55 | NKIB 5911 | 80 | 38 | 63 | 63 | 1.0 | 58500 | 99500 | 6000 | 10100 |
| 60 | NKIB 5912 | 85 | 38 | 68 | 68 | 1.0 | 61500 | 108000 | 6250 | 11000 |
| 65 | NKIB 5913 | 90 | 38 | 72 | 72 | 1.0 | 62500 | 112000 | 6350 | 11400 |
| 70 | NKIB 5914 | 100 | 45 | 80 | 80 | 1.0 | 85500 | 156000 | 8750 | 15900 |

Notes: 1) These values are the allowable minimum dimensions of the chamfer dimension *r*.

Needle roller bearings with three-point contact ball bearings series NKIB 59

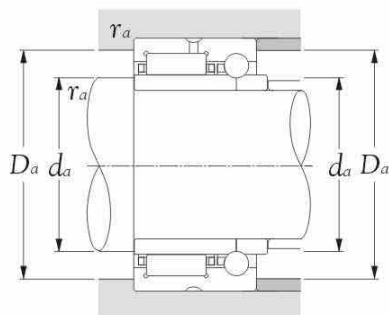

| dynamic C | Basic load ratings (Axial) | | dynamic C | static Co | Max runout speed | | Abutment dimensions | | | Weight kg. |
|--------------|----------------------------|--------------|--------------|--------------|------------------|------|---------------------|--------------|-----------------|---------------|
| | static Co | dynamic C | | | grease | oil | d_a mm | D_a max | r_{as} max | |
| N | | kgf | | | r/min | | | | | |
| 2750 | 4200 | 280 | 430 | 13000 | 20000 | 17.5 | 25.5 | 0.3 | 0.052 | |
| 2960 | 4900 | 300 | 495 | 12000 | 18000 | 19.5 | 27.5 | 0.3 | 0.058 | |
| 4650 | 7400 | 475 | 755 | 11000 | 16000 | 22.5 | 34.5 | 0.3 | 0.107 | |
| 5000 | 8650 | 510 | 880 | 9500 | 14000 | 24.5 | 36.5 | 0.3 | 0.122 | |
| 5150 | 9250 | 525 | 945 | 8500 | 13000 | 27.5 | 39.5 | 0.3 | 0.134 | |
| 5600 | 11200 | 570 | 1140 | 7500 | 11000 | 32.5 | 44.5 | 0.3 | 0.151 | |
| 7050 | 14900 | 720 | 1520 | 6500 | 9500 | 40.0 | 50.0 | 0.6 | 0.247 | |
| 8700 | 19400 | 890 | 1980 | 5500 | 8500 | 45.0 | 57.0 | 0.6 | 0.320 | |
| 9100 | 21400 | 925 | 2180 | 5000 | 7500 | 50.0 | 63.0 | 0.6 | 0.380 | |
| 9600 | 24300 | 980 | 2480 | 4300 | 6500 | 55.0 | 67.0 | 0.6 | 0.385 | |
| 11400 | 29400 | 1170 | 3000 | 4300 | 6500 | 61.0 | 74.0 | 1.0 | 0.555 | |
| 11800 | 32000 | 1200 | 3250 | 4000 | 6000 | 66.0 | 79.0 | 1.0 | 0.595 | |
| 12100 | 34000 | 1240 | 3500 | 3700 | 5500 | 71.0 | 84.0 | 1.0 | 0.640 | |
| 15900 | 44500 | 1620 | 4550 | 3300 | 5000 | 76.0 | 94.0 | 1.0 | 0.985 | |



Roller followers



TECHNICAL SUPPLEMENT

T118 - 120

PRODUCT INFORMATION

P122 - 129



NATR

P122 - 123



NATR..PP

P122 - 123



NATV

P124 - 125



NATV..PP

P124 - 125



NUTR

P126 - 127



NA 22..2RSR

P128 - 129



RNA 22..2RSR

P128 - 129

1. Bearing materials

KSM Yoke-type Track Rollers include the series RNA 22 (without inner ring) and series NA 22 (with inner ring), whose outer ring is not guided in the axial direction; and the NATR, NATV and series NUTR whose outer ring is guided in the axial direction. With the series RNA 22 and NA 22, a needle roller and cage assembly and steel plate reinforced synthetic rubber seal are built into the outer ring, and these components are inseparable from each other. Since the bearing can be shifted in the axial direction, the shaft must have a thrust washer or flange to guide the outer ring.

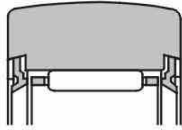

Fig. 1 Series RNA 22..2RSR

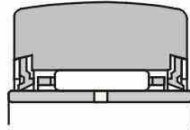

Fig. 2 Series NA 22..2RSR

With the series NATR, NATV, the outer ring is guided in the axial direction by two side plates that are press-fit into the inner ring. The series NATR bearing has an integral cage and needle roller assembly. The series NATV full-complement type can carry a larger load compared with the series NATR bearing, although its limiting speed is low.

On **KSM** Yoke-type Track Rollers, a labyrinth occurs between the outer ring and inner ring to provide sealing. For enhanced sealing, one type of bearing (suffix PP) incorporates a synthetic rubber seal between the outer ring and inner ring.

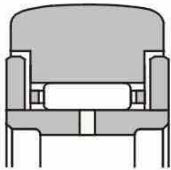

Fig. 3 Series NATR

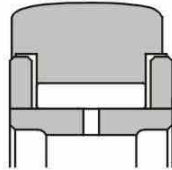

Fig. 4 Series NATV

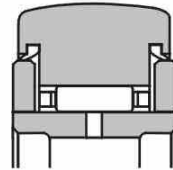

Fig. 5 Series NATR..PP

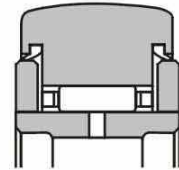

Fig. 6 Series NATV..PP

The rollers of the series NUTR are full-complement type rollers whose rolling elements are double-row cylindrical rollers. Compared with full-complement needle roller bearings, they feature greater load carrying capacity and thus are suitable for heavy load applications. Their outer ring incorporates a press-fit steel plate to form a labyrinth between the side plates on both sides of the inner ring to ensure reliable sealing and maintain the position of the side plates. The outer ring is guided in the axial direction by the outer ring rib and end faces of the cylindrical rollers, and can carry some axial load. The inner ring and side plates are tightened in the axial direction to eliminate clearance.

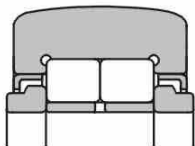
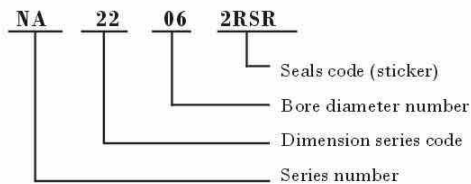

Fig. 7 Series NUTR

2. Interpreting bearing numbers

The bearing numbers of **KSM** Yoke-type Track Rollers comprise a series number, dimension series code, dimension code, and suffix.

Series RNA, NA



Series NATR, NATV

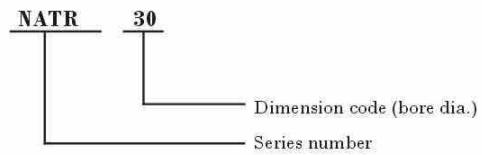

Series NUTR

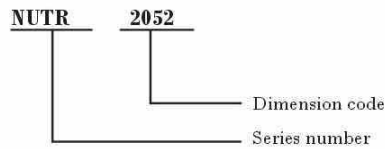

3. Bearing fits and radial clearance

The tolerance class of the shaft in relation to a bearing with an inner ring is g6 (h6). If a shaft is used directly as a raceway surface (series RNA 22), the tolerance class of the shaft must be k5 (k6). Usually, the outer ring of an **KSM** Yoke-type Track Roller is not built into a housing.

Table 1 Radial clearance

(Unit: μm)

| Enveloping circle diameter F_w (mm) | | Clearance | | | | | | | |
|--|-------|-----------|------|--------|------|------|------|------|------|
| | | C2 | | Normal | | C3 | | C4 | |
| over | incl. | min. | max. | min. | max. | min. | max. | min. | max. |
| 3 | 6 | 0 | 10 | 3 | 17 | 15 | 30 | 20 | 40 |
| 6 | 10 | 0 | 12 | 5 | 20 | 15 | 30 | 25 | 45 |
| 10 | 18 | 0 | 15 | 5 | 25 | 15 | 35 | 30 | 55 |
| 18 | 30 | 0 | 20 | 10 | 30 | 20 | 40 | 40 | 65 |
| 30 | 50 | 0 | 25 | 10 | 40 | 25 | 55 | 50 | 80 |
| 50 | 80 | 0 | 30 | 15 | 50 | 30 | 65 | 60 | 100 |
| 80 | 100 | 0 | 35 | 20 | 55 | 35 | 75 | 70 | 115 |

4. Mounting dimensions

If a bearing lacks a function for axially guiding the outer ring, as in the case of the series RNA 22 series or NA 22 bearings, the shaft must be provided with a flange or thrust washer to guide the outer ring. The guide surface should preferably be hardened, and the guide width should be at least half the outer ring width. At minimum, the guide surface must be finished by a turning process, and must be smooth and free from burrs. The mounting surface for series NATR, NATV and NUTR rollers must at least adopt dimensions e specified in the associated bearing tables so that their side plates can make full contact.

5. Lubrication

Rollers having a synthetic rubber seal (suffix PP) and those of the full-complement type are pre-filled with lithium soap grease and can operate at a temperature range of 25 °C to 100 °C. The internal bearing grease can be replenished through a lubrication hole on the inner ring. The rollers must be installed so that the lubrication hole is located in a non-load zone. The series NATV and NUTR being full-complement types, must be lubricated more frequently than the caged types.

Roller followers yoke type truck rollers series NATR

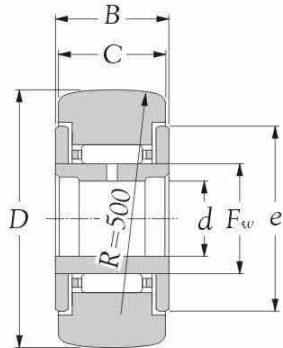

Type NATR
(With cage)

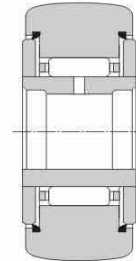

Type NATR..PP
(Double seals with cage)

| Inner bore D 0 ^{+0.05} mm | Bearing number | | Boundary dimensions | | | | | Basic load ratings | | | |
|---|----------------|------------|-----------------------------------|----|----|----|----------------|--------------------|--------------------------|--------------|--------------------------|
| | | | B | C | d | e | F _w | dynamic C | static C ₀ | dynamic C | static C ₀ |
| | | | mm | | | | | N | | | |
| 16 | NATR 5 | NATR 5 PP | 12 ⁰ _{-0.180} | 11 | 5 | 12 | 8.0 | 3850 | 3950 | 395 | 400 |
| 19 | NATR 6 | NATR 6 PP | 12 ⁰ _{-0.180} | 11 | 6 | 14 | 10.0 | 4500 | 5100 | 460 | 520 |
| 24 | NATR 8 | NATR 8 PP | 15 ⁰ _{-0.180} | 14 | 8 | 19 | 12.0 | 6600 | 7300 | 675 | 745 |
| 30 | NATR 10 | NATR 10 PP | 15 ⁰ _{-0.180} | 14 | 10 | 23 | 15.0 | 7500 | 9100 | 765 | 930 |
| 32 | NATR 12 | NATR 12 PP | 15 ⁰ _{-0.180} | 14 | 12 | 25 | 17.0 | 8500 | 11100 | 865 | 1130 |
| 35 | NATR 15 | NATR 15 PP | 19 ⁰ _{-0.210} | 18 | 15 | 27 | 20.0 | 13000 | 20100 | 1320 | 2050 |
| 40 | NATR 17 | NATR 17 PP | 21 ⁰ _{-0.210} | 20 | 17 | 32 | 22.0 | 13600 | 22100 | 1390 | 2250 |
| 47 | NATR 20 | NATR 20 PP | 25 ⁰ _{-0.210} | 24 | 20 | 37 | 25.0 | 20300 | 33000 | 2070 | 3350 |
| 52 | NATR 25 | NATR 25 PP | 25 ⁰ _{-0.210} | 24 | 25 | 42 | 30.0 | 22300 | 39500 | 2280 | 4000 |
| 62 | NATR 30 | NATR 30 PP | 29 ⁰ _{-0.210} | 28 | 30 | 51 | 38.0 | 35000 | 64000 | 3600 | 6550 |
| 72 | NATR 35 | NATR 35 PP | 29 ⁰ _{-0.210} | 28 | 35 | 58 | 44.5 | 38000 | 74500 | 3850 | 7600 |
| 80 | NATR 40 | NATR 40 PP | 32 ⁰ _{-0.250} | 30 | 40 | 66 | 50.0 | 48500 | 90000 | 4950 | 9150 |
| 85 | NATR 45 | NATR 45 PP | 32 ⁰ _{-0.250} | 30 | 45 | 71 | 55.0 | 50500 | 97500 | 5150 | 9950 |
| 90 | NATR 50 | NATR 50 PP | 32 ⁰ _{-0.250} | 30 | 50 | 76 | 60.0 | 52000 | 105000 | 5300 | 10700 |

Roller followers yoke type truck rollers series NATR

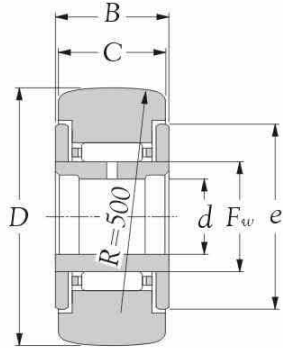

Type NATR
(With cage)

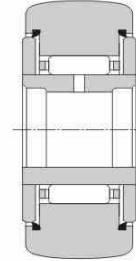

Type NATR..PP
(Double seals with cage)

| Spherical outer ring | Load ratings of truck | | | Max runout speed | | Weight kg. |
|-------------------------|--------------------------------|---------------------------|----------------------------------|------------------|--------------|---------------|
| | Cylindrical outer ring N | Cylindrical outer ring | Cylindrical outer ring kgf | grease r/min | oil r/min | |
| 1080 | 3400 | 110 | 350 | ※19000 | ※25000 | 0.018 |
| 1380 | 4050 | 141 | 415 | ※15000 | ※20000 | 0.025 |
| 1900 | 6650 | 193 | 680 | ※12000 | ※16000 | 0.042 |
| 2620 | 7700 | 267 | 785 | 10000 | ※13000 | 0.061 |
| 2860 | 8200 | 291 | 835 | 9000 | ※12000 | 0.069 |
| 3200 | 11900 | 325 | 1220 | 7500 | 10000 | 0.098 |
| 3850 | 14500 | 390 | 1480 | 7000 | 9000 | 0.140 |
| 4700 | 21000 | 480 | 2150 | 6000 | 8000 | 0.246 |
| 5500 | 23300 | 565 | 2370 | 5000 | 6500 | 0.275 |
| 6950 | 33000 | 710 | 3350 | 4000 | 5500 | 0.470 |
| 8050 | 37000 | 820 | 3750 | 3300 | 4500 | 0.635 |
| 9800 | 44500 | 1000 | 4500 | 3000 | 4000 | 0.875 |
| 10400 | 47000 | 1060 | 4800 | 2700 | 3600 | 0.910 |
| 11400 | 50000 | 1160 | 5100 | 2500 | 3300 | 0.960 |

Notes: Limiting speed of sealed type bearings marked with ※ is approximately 10 000 r/min.



Roller followers yoke type truck rollers series NATV

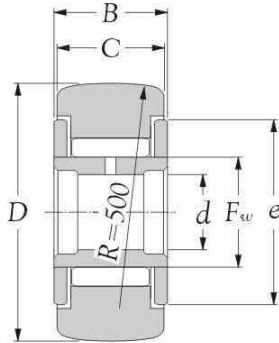

Type NATV
(Full complement type)

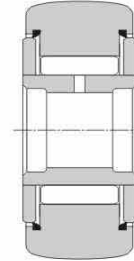

Type NATV..PP
(Full complement type with seals)

| Inner bore $D_{0/-0.05}$ mm | Bearing number | | Boundary dimensions | | | | | Basic load ratings | | | |
|-----------------------------------|----------------|------------|-----------------------------------|----|----|----|----------------|--------------------|--------------------------|--------------|--------------------------|
| | | | B | C | d | e | F _w | dynamic C | static C ₀ | dynamic C | static C ₀ |
| | | | mm | | | | | N | | | |
| 16 | NATV 5 | NATV 5 PP | 12 ⁰ _{-0.180} | 11 | 5 | 12 | 8.0 | 6250 | 8900 | 640 | 910 |
| 19 | NATV 6 | NATV 6 PP | 12 ⁰ _{-0.180} | 11 | 6 | 14 | 10.0 | 7200 | 11200 | 735 | 1140 |
| 24 | NATV 8 | NATV 8 PP | 15 ⁰ _{-0.180} | 14 | 8 | 19 | 12.0 | 10300 | 15500 | 1050 | 1580 |
| 30 | NATV 10 | NATV 10 PP | 15 ⁰ _{-0.180} | 14 | 10 | 23 | 15.0 | 11700 | 19500 | 1190 | 1980 |
| 32 | NATV 12 | NATV 12 PP | 15 ⁰ _{-0.180} | 14 | 12 | 25 | 17.0 | 12600 | 22100 | 1280 | 2250 |
| 35 | NATV 15 | NATV 15 PP | 19 ⁰ _{-0.210} | 18 | 15 | 27 | 20.0 | 18000 | 37000 | 1830 | 3750 |
| 40 | NATV 17 | NATV 17 PP | 21 ⁰ _{-0.210} | 20 | 17 | 32 | 22.0 | 18900 | 40500 | 1930 | 4150 |
| 47 | NATV 20 | NATV 20 PP | 25 ⁰ _{-0.210} | 24 | 20 | 37 | 25.0 | 28400 | 60000 | 2900 | 6100 |
| 52 | NATV 25 | NATV 25 PP | 25 ⁰ _{-0.210} | 24 | 25 | 42 | 30.0 | 31000 | 72000 | 3150 | 7350 |
| 62 | NATV 30 | NATV 30 PP | 29 ⁰ _{-0.210} | 28 | 30 | 51 | 38.0 | 46500 | 112000 | 4750 | 11400 |
| 72 | NATV 35 | NATV 35 PP | 29 ⁰ _{-0.210} | 28 | 35 | 58 | 44.5 | 51000 | 130000 | 5200 | 13300 |
| 80 | NATV 40 | NATV 40 PP | 32 ⁰ _{-0.250} | 30 | 40 | 66 | 50.0 | 67500 | 167000 | 6850 | 17100 |
| 90 | NATV 50 | NATV 50 PP | 32 ⁰ _{-0.250} | 30 | 50 | 76 | 60.0 | 74500 | 200000 | 7600 | 20400 |

Roller followers yoke type truck rollers series NATV

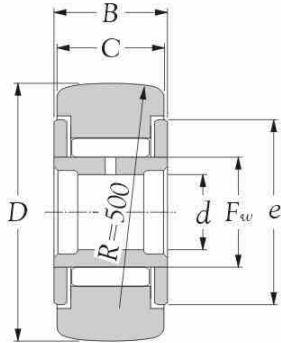

Type NATV
(Full complement type)

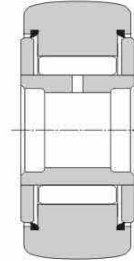

Type NATV.PP
(Full complement type with seals)

| Spherical outer ring | Load ratings of truck | | | Max runout speed | | Weight kg. |
|-------------------------|--------------------------------|---------------------------|----------------------------------|------------------|--------------|---------------|
| | Cylindrical outer ring N | Cylindrical outer ring | Cylindrical outer ring kgf | grease r/min | oil r/min | |
| 1080 | 3400 | 110 | 350 | ※13000 | ※16000 | 0.020 |
| 1380 | 4050 | 141 | 415 | 10000 | ※13000 | 0.027 |
| 1900 | 6650 | 193 | 680 | 8500 | ※11000 | 0.044 |
| 2620 | 7700 | 267 | 785 | 6500 | 8500 | 0.065 |
| 2860 | 8200 | 291 | 835 | 6000 | 7500 | 0.074 |
| 3200 | 11900 | 325 | 1220 | 5000 | 6500 | 0.102 |
| 3850 | 14500 | 390 | 1480 | 4500 | 6000 | 0.145 |
| 4700 | 21000 | 480 | 2150 | 4000 | 5000 | 0.254 |
| 5500 | 23300 | 565 | 2370 | 3300 | 4500 | 0.285 |
| 6950 | 33000 | 710 | 3350 | 2600 | 3500 | 0.481 |
| 8050 | 37000 | 820 | 3750 | 2200 | 2900 | 0.647 |
| 9800 | 44500 | 1000 | 4500 | 2000 | 2600 | 0.890 |
| 11400 | 50000 | 1160 | 5100 | 1600 | 2100 | 0.990 |

Notes: Limiting speed of sealed type bearings marked with ※ is approximately 10 000 r/min.



Roller bearing with tapered roller cylindrical roller bearings series NUTR, NKXR..Z

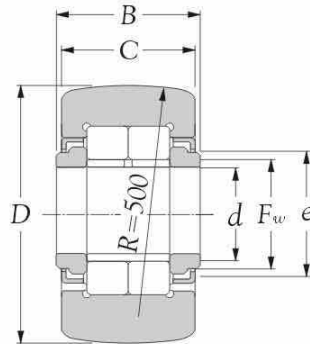

| Inner bore D <small>0/+0.05</small> mm | Bearing number | Boundary dimensions | | | | | | Basic load ratings | | | |
|---|----------------|-----------------------------------|-----|-----|-----|-------|------------------------|--------------------|-----------------|----------------|-----------------|
| | | B | C | d | e | F_w | r_s mm ¹⁾ | dynamic C | static C_o | dynamic C | static C_o |
| | | mm | | | | | | N | | | |
| 35 | NUTR 15 | 19 ⁰ _{-0.210} | 18 | 15 | 20 | 19.0 | 0.3 | 22300 | 25700 | 2280 | 2620 |
| 40 | NUTR 17 | 21 ⁰ _{-0.210} | 20 | 17 | 22 | 21.5 | 0.3 | 24100 | 29100 | 2450 | 2970 |
| 42 | NUTR 1542 | 19 ⁰ _{-0.210} | 18 | 15 | 20 | 19.0 | 0.3 | 22300 | 25700 | 2280 | 2620 |
| 47 | NUTR 1747 | 21 ⁰ _{-0.210} | 20 | 17 | 22 | 21.5 | 0.3 | 24100 | 29100 | 2450 | 2970 |
| 47 | NUTR 20 | 25 ⁰ _{-0.210} | 24 | 20 | 27 | 25.5 | 0.3 | 38500 | 48000 | 3950 | 4900 |
| 52 | NUTR 2052 | 25 ⁰ _{-0.210} | 24 | 20 | 27 | 25.5 | 0.3 | 38500 | 48000 | 3950 | 4900 |
| 52 | NUTR 25 | 25 ⁰ _{-0.210} | 24 | 25 | 31 | 30.0 | 0.3 | 42500 | 57500 | 4350 | 5850 |
| 62 | NUTR 2562 | 25 ⁰ _{-0.210} | 24 | 25 | 31 | 30.0 | 0.3 | 42500 | 57500 | 4350 | 5850 |
| 62 | NUTR 30 | 29 ⁰ _{-0.210} | 28 | 30 | 38 | 35.0 | 0.3 | 56500 | 72500 | 5750 | 7400 |
| 72 | NUTR 3072 | 29 ⁰ _{-0.210} | 28 | 30 | 38 | 35.0 | 0.3 | 56500 | 72500 | 5750 | 7400 |
| 72 | NUTR 35 | 29 ⁰ _{-0.210} | 28 | 35 | 44 | 41.5 | 0.6 | 62000 | 85500 | 6350 | 8700 |
| 80 | NUTR 3580 | 29 ⁰ _{-0.210} | 28 | 35 | 44 | 41.5 | 0.6 | 62000 | 85500 | 6350 | 8700 |
| 80 | NUTR 40 | 32 ⁰ _{-0.250} | 30 | 40 | 51 | 47.5 | 0.6 | 87000 | 125000 | 8850 | 12700 |
| 85 | NUTR 45 | 32 ⁰ _{-0.250} | 30 | 45 | 55 | 52.5 | 0.6 | 92000 | 137000 | 9350 | 14000 |
| 90 | NUTR 4090 | 32 ⁰ _{-0.250} | 30 | 40 | 51 | 47.5 | 0.6 | 87000 | 125000 | 8850 | 12700 |
| 90 | NUTR 50 | 35 ⁰ _{-0.250} | 30 | 50 | 60 | 57.0 | 0.6 | 96500 | 150000 | 9800 | 15300 |
| 100 | NUTR 45100 | 32 ⁰ _{-0.250} | 30 | 45 | 55 | 52.5 | 0.6 | 92000 | 137000 | 9350 | 14000 |
| 110 | NUTR 50110 | 32 ⁰ _{-0.250} | 30 | 50 | 60 | 57.0 | 0.6 | 96500 | 150000 | 9800 | 15300 |

Notes: 1) These values are the allowable minimum dimensions of the chamfer dimension r .

Rolling ball bearings type of the ball cylindrical roller bearings series NKXR, NKXR..Z

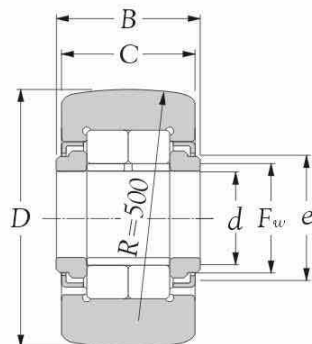

| Spherical outer ring | Load ratings of truck | | | Max runout speed grease r/min | Weight kg (s). |
|-------------------------|--------------------------------|---------------------------|----------------------------------|-------------------------------------|-------------------|
| | Cylindrical outer ring N | Cylindrical outer ring | Cylindrical outer ring kgf | | |
| 3200 | 11900 | 325 | 1220 | 5500 | 0.100 |
| 3850 | 14500 | 390 | 1480 | 4700 | 0.147 |
| 4100 | 14300 | 415 | 1460 | 5500 | 0.160 |
| 4700 | 17000 | 480 | 1740 | 4700 | 0.222 |
| 4700 | 21000 | 480 | 2150 | 4000 | 0.245 |
| 5550 | 23300 | 565 | 2370 | 4000 | 0.321 |
| 5550 | 23300 | 565 | 2370 | 3300 | 0.281 |
| 6950 | 27800 | 710 | 2830 | 3300 | 0.450 |
| 6950 | 33000 | 710 | 3350 | 2900 | 0.466 |
| 8050 | 38500 | 820 | 3900 | 2900 | 0.697 |
| 8050 | 37000 | 820 | 3750 | 2400 | 0.630 |
| 9800 | 41000 | 1000 | 4150 | 2400 | 0.840 |
| 9800 | 44500 | 1000 | 4500 | 2100 | 0.817 |
| 10400 | 47000 | 1060 | 4800 | 1900 | 0.883 |
| 11400 | 50000 | 1160 | 5100 | 2100 | 1.130 |
| 11400 | 50000 | 1160 | 5100 | 1800 | 0.950 |
| 13000 | 55500 | 1330 | 5650 | 1900 | 1.400 |
| 14700 | 61000 | 1500 | 6200 | 1800 | 1.690 |

Roller followers yoke type truck rollers sealed type series NA 22..2RSR, RNA 22..2RSR

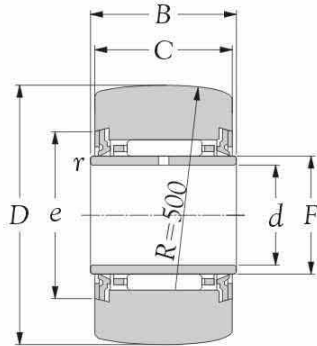

Type NA 22..2RSR
(With inner ring and double seals)

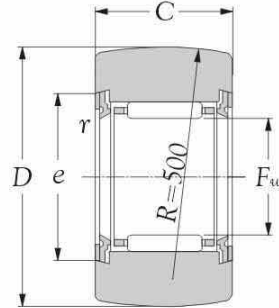

Type RNA 22..2RSR
(Without inner ring and double seals)

| Inner bore D 0/+0.05 mm | Bearing number | | Boundary dimensions | | | | | | | Basic load ratings | | | | | | |
|----------------------------------|----------------|---------------|---------------------|------|----|--|----|----|-------------------------|--------------------|--------------------------|--------------|--------------------------|--|-----|--|
| | | | B | C | d | F _w | e | F | r (s mm ⁻¹) | dynamic C | static C ₀ | dynamic C | static C ₀ | | | |
| | | | | | | | | | | | | | N | | kgf | |
| 19 | NA 22/6 2RSR | RNA 22/6 2RSR | 12 | 11.8 | 6 | 10 ^{+0.022} _{+0.013} | 16 | 10 | 0.3 | 4300 | 3950 | 435 | 405 | | | |
| 24 | NA 22/8 2RSR | RNA 22/8 2RSR | 12 | 11.8 | 8 | 12 ^{+0.027} _{+0.016} | 18 | 12 | 0.3 | 4850 | 4900 | 495 | 500 | | | |
| 30 | NA 2200 2RSR | RNA 2200 2RSR | 14 | 13.8 | 10 | 14 ^{+0.027} _{+0.016} | 20 | 14 | 0.3 | 7200 | 8500 | 735 | 865 | | | |
| 32 | NA 2201 2RSR | RNA 2201 2RSR | 14 | 13.8 | 12 | 16 ^{+0.027} _{+0.020} | 22 | 16 | 0.3 | 7750 | 9700 | 795 | 990 | | | |
| 35 | NA 2202 2RSR | RNA 2202 2RSR | 14 | 13.8 | 15 | 20 ^{+0.033} _{+0.020} | 26 | 20 | 0.3 | 9500 | 13400 | 970 | 1370 | | | |
| 40 | NA 2203 2RSR | RNA 2203 2RSR | 16 | 15.8 | 17 | 22 ^{+0.033} _{+0.020} | 28 | 22 | 0.3 | 10100 | 14900 | 1030 | 1520 | | | |
| 47 | NA 2204 2RSR | RNA 2204 2RSR | 18 | 17.8 | 20 | 25 ^{+0.033} _{+0.020} | 33 | 25 | 0.3 | 16500 | 22100 | 1680 | 2250 | | | |
| 52 | NA 2205 2RSR | RNA 2205 2RSR | 18 | 17.8 | 25 | 30 ^{+0.033} _{+0.020} | 38 | 30 | 0.3 | 17400 | 25000 | 1770 | 2550 | | | |
| 62 | NA 2206 2RSR | RNA 2206 2RSR | 20 | 19.8 | 30 | 35 ^{+0.041} _{+0.025} | 43 | 35 | 0.3 | 20900 | 33500 | 2130 | 3400 | | | |
| 72 | NA 2207 2RSR | RNA 2207 2RSR | 23 | 22.7 | 35 | 42 ^{+0.041} _{+0.025} | 50 | 42 | 0.6 | 25700 | 46000 | 2630 | 4700 | | | |
| 80 | NA 2208 2RSR | RNA 2208 2RSR | 23 | 22.7 | 40 | 48 ^{+0.041} _{+0.025} | 57 | 48 | 0.6 | 27800 | 53500 | 2830 | 5450 | | | |
| 85 | NA 2209 2RSR | RNA 2209 2RSR | 23 | 22.7 | 45 | 52 ^{+0.049} _{+0.030} | 62 | 52 | 0.6 | 28600 | 57000 | 2920 | 5800 | | | |
| 90 | NA 2210 2RSR | RNA 2210 2RSR | 23 | 22.7 | 50 | 58 ^{+0.049} _{+0.030} | 68 | 58 | 0.6 | 30500 | 64000 | 3100 | 6500 | | | |

Notes: 1) These values are the allowable minimum dimensions of the chamfer dimension r.

Roller followers yoke type truck rollers sealed type series NA 22..2RSR, RNA 22..2RSR

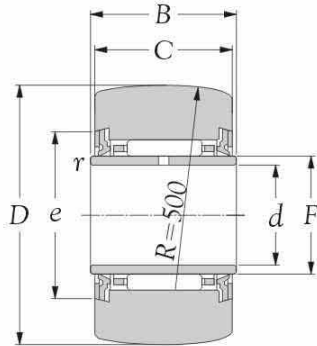

Type NA 22..2RSR
(With inner ring and double seals)

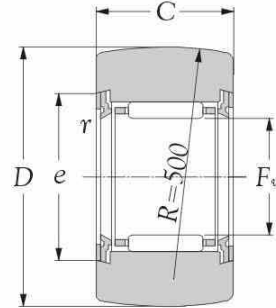

Type RNA 22..2RSR
(Without inner ring and double seals)

| Spherical outer ring | Load ratings of truck | | | Max runout speed grease r/min | Weight | |
|-------------------------|---------------------------|---------------------------|---------------------------|-------------------------------------|---------------------|----------------------|
| | Cylindrical outer ring | Cylindrical outer ring | Cylindrical outer ring | | Typt NA 22..2RSR | Typt RNA 22..2RSR |
| | N | kgf | kgf | | kg. | kg. |
| 1380 | 4400 | 141 | 445 | 10000 | 0.023 | 0.018 |
| 1900 | 5500 | 193 | 565 | 10000 | 0.035 | 0.027 |
| 2620 | 7550 | 267 | 770 | 10000 | 0.060 | 0.052 |
| 2860 | 8050 | 291 | 820 | 9500 | 0.067 | 0.057 |
| 3200 | 8800 | 325 | 900 | 7500 | 0.075 | 0.060 |
| 3850 | 10900 | 390 | 1110 | 7000 | 0.113 | 0.094 |
| 4700 | 14800 | 480 | 1510 | 6000 | 0.176 | 0.152 |
| 5550 | 16400 | 565 | 1670 | 5000 | 0.209 | 0.179 |
| 6950 | 22200 | 710 | 2260 | 4300 | 0.322 | 0.284 |
| 8050 | 28700 | 820 | 2930 | 3600 | 0.506 | 0.432 |
| 9800 | 32000 | 1000 | 3250 | 3100 | 0.623 | 0.530 |
| 10400 | 34000 | 1060 | 3450 | 2900 | 0.638 | 0.545 |
| 11400 | 36000 | 1160 | 3650 | 2600 | 0.682 | 0.563 |





Cam followers



TECHNICAL SUPPLEMENT

T132 - 133

PRODUCT INFORMATION

P134 - 139

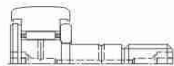

KR

P134 - 135

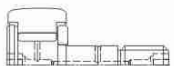

KRV

P136 - 137



NUKR

P138 - 139

1. Bearing materials

KSM Stud-type Track Rollers are available in three basic series: the series KR, whose rolling elements are needle rollers retained and guided by a cage; the full-complement series KRV lacking a cage, whose rolling elements are needle rollers; and the series NUKR, a full-complement type whose rolling elements are double-row cylindrical rollers. The cage of the stud-type track rollers is pressed steel. However, cages of molded polyamide reinforced with glass fiber or carbon fibre may be used. The carbon fibre cage features a maximum allowable operating temperature of 120° C and maximum allowable continuous operating temperature of 100° C. The series KR is suitable for high-speed applications because the cage guides the needle rollers. Compared with a full-complement configuration, this bearing's larger internal volume holds a larger amount of grease, which contributes to relatively extended relubrication intervals. Also available is a variant (suffix PP) with synthetic rubber seal located between the outer ring, flange, and side plate.

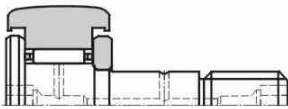

Fig. 1 Series KR

Compared with the series KR, the track roller series KRV has more needle rollers and therefore is suitable for heavy load applications, but it has a lower limiting speed. A variant (suffix PP) with seals is also available. Because this bearing holds less grease, the relubrication intervals for this type are shorter.

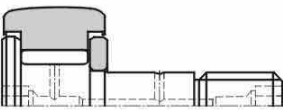

Fig. 2 Series KRV

Compared with full-complement needle roller bearings, the series NUKR track rollers can carry a greater load and are therefore suitable for applications involving heavy load and impact load, as they are full-complement types using double-row cylindrical rollers as rolling elements. They are guided in the axial direction by the outer ring rib and end faces of cylindrical rollers, and can carry some axial load. Although they are a full-complement configuration, their limiting speed is greater than that of series KRV rollers. Their outer ring incorporates a press-fit steel plate to form a labyrinth between the flange and the outer surface of the side plate. Because there is limited space available for adding grease to the bearing, the bearing must be relubricated more frequently.

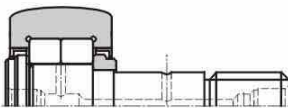

Fig. 3 Series NUKR

2. Interpreting bearing numbers

The bearing numbers of **KSM** Stud-type Track Rollers comprise a series number, dimension code (outside diameter), and suffix.

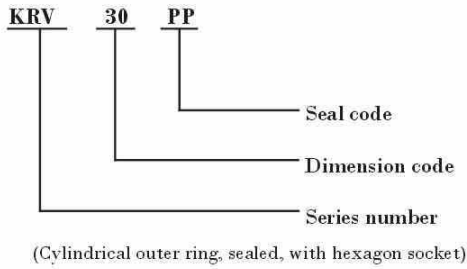
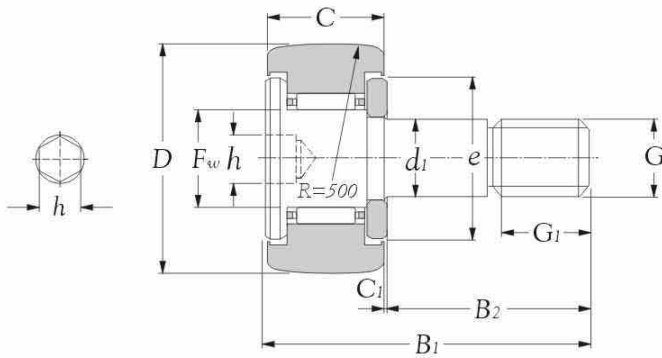

Fig. 4

3. Lubrication

The rollers having synthetic rubber seals (suffix PP) as well as the full-complement type are pre-filled with lithium soap grease and can operate at a temperature range of -25°C to 100°C . The inside of the bearing can be refilled through a grease nipple installed on the bearing-side end face (flange end face) or threaded end face of the stud. Any lubrication holes not used for relubrication must be plugged. The necessary grease nipple and plug are included in the package and must be installed on the roller before the cam follower is mounted.

Cam followers stud type truck rollers series KR



Type KR (10~19 mm)

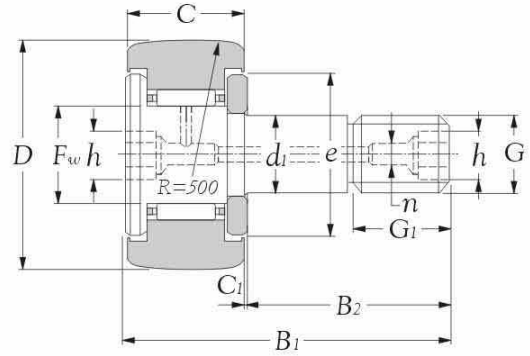

Type KR (22~26 mm)

| Inner bore D 0/+0.05 mm | Bearing number | | Boundary dimensions | | | | | | | | | | | | |
|----------------------------------|----------------|----------|---------------------|-----------------------------------|----------------|----------------|----------------|------------|----------------|----------------|-----|----------------|---|------|----|
| | | | C | d ₁ | F _w | B ₁ | B ₂ | G | G ₁ | C ₁ | n | B ₃ | a | e | h |
| 10 | KR 10 | KR 10 PP | 7 | 3 ⁰ _{-0.010} | 4.00 | 17 | 9.0 | M 3 X 0.5 | 5.0 | 0.5 | - | - | - | 7.0 | - |
| 12 | KR 12 | KR 12 PP | 8 | 4 ⁰ _{-0.012} | 4.80 | 20 | 11.0 | M 4 X 0.7 | 6.0 | 0.5 | - | - | - | 8.5 | - |
| 13 | KR 13 | KR 13 PP | 9 | 5 ⁰ _{-0.012} | 5.75 | 23 | 13.0 | M 5 X 0.8 | 7.5 | 0.5 | - | - | - | 9.5 | - |
| 16 | KR 16 | KR 16 PP | 11 | 6 ⁰ _{-0.012} | 8.00 | 28 | 16.0 | M 6 X 1.0 | 8.0 | 0.6 | 42) | - | - | 12.0 | 4 |
| 19 | KR 19 | KR 19 PP | 11 | 8 ⁰ _{-0.015} | 10.00 | 32 | 20.0 | M 8 X 1.25 | 10.0 | 0.6 | 42) | - | - | 14.0 | 4 |
| 22 | KR 22 | KR 22 PP | 12 | 10 ⁰ _{-0.015} | 12.00 | 36 | 23.0 | M 10 X 1.0 | 12.0 | 0.6 | 4 | - | - | 17.0 | 5 |
| 26 | KR 26 | KR 26 PP | 12 | 10 ⁰ _{-0.015} | 12.00 | 36 | 23.0 | M 10 X 1.0 | 12.0 | 0.6 | 4 | - | - | 17.0 | 5 |
| 30 | KR 30 | KR 30 PP | 14 | 12 ⁰ _{-0.018} | 15.00 | 40 | 25.0 | M 12 X 1.5 | 13.0 | 0.6 | 6 | 6 | 3 | 23.0 | 6 |
| 32 | KR 32 | KR 32 PP | 14 | 12 ⁰ _{-0.018} | 15.00 | 40 | 25.0 | M 12 X 1.5 | 13.0 | 0.6 | 6 | 6 | 3 | 23.0 | 6 |
| 35 | KR 35 | KR 35 PP | 18 | 16 ⁰ _{-0.018} | 18.00 | 52 | 32.5 | M 16 X 1.5 | 17.0 | 0.8 | 6 | 8 | 3 | 27.0 | 8 |
| 40 | KR 40 | KR 40 PP | 20 | 18 ⁰ _{-0.018} | 22.00 | 58 | 36.5 | M 18 X 1.5 | 19.0 | 0.8 | 6 | 8 | 3 | 32.0 | 8 |
| 47 | KR 47 | KR 47 PP | 24 | 20 ⁰ _{-0.021} | 25.00 | 66 | 40.5 | M 20 X 1.5 | 21.0 | 0.8 | 8 | 9 | 4 | 37.0 | 10 |
| 52 | KR 52 | KR 52 PP | 24 | 20 ⁰ _{-0.021} | 25.00 | 66 | 40.5 | M 20 X 1.5 | 21.0 | 0.8 | 8 | 9 | 4 | 37.0 | 10 |
| 62 | KR 62 | KR 62 PP | 29 | 24 ⁰ _{-0.021} | 30.00 | 80 | 49.5 | M 24 X 1.5 | 25.0 | 0.8 | 8 | 11 | 4 | 44.0 | 14 |
| 72 | KR 72 | KR 72 PP | 29 | 24 ⁰ _{-0.021} | 30.00 | 80 | 49.5 | M 24 X 1.5 | 25.0 | 0.8 | 8 | 11 | 4 | 44.0 | 14 |
| 80 | KR 80 | KR 80 PP | 35 | 30 ⁰ _{-0.021} | 38.00 | 100 | 63.0 | M 30 X 1.5 | 32.0 | 1.0 | 8 | 15 | 4 | 53.0 | 14 |
| 85 | KR 85 | KR 85 PP | 35 | 30 ⁰ _{-0.021} | 38.00 | 100 | 63.0 | M 30 X 1.5 | 32.0 | 1.0 | 8 | 15 | 4 | 53.0 | - |
| 90 | KR 90 | KR 90 PP | 35 | 30 ⁰ _{-0.021} | 38.00 | 100 | 63.0 | M 30 X 1.5 | 32.0 | 1.0 | 8 | 15 | 4 | 53.0 | 14 |

Cam followers stud type truck rollers series KR

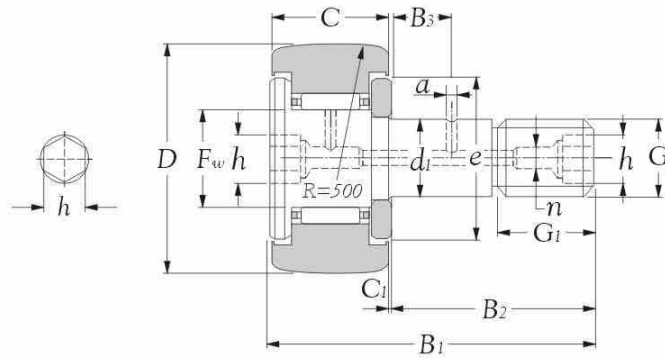

Type KR (30~90 mm)

| Basic load ratings | | | | Load ratings of truck | | | | Max runout speed | | Maximum tightening torque | | Weight | Stud diameter |
|--------------------|--------|---------|--------|-----------------------|-------------|------------|-------------|------------------|--------|---------------------------|-------|--------|---------------|
| dynamic | static | dynamic | static | Spherical | Cylindrical | Spherical | Cylindrical | grease | oil | | | kg(s). | mm |
| C | Co | C | Co | outer ring | outer ring | outer ring | outer ring | | | N.m | Kgf.m | | |
| N | | kgf | | N | N | kgf | kgf | r/min | | | | | |
| 1510 | 1140 | 154 | 116 | 560 | 1360 | 57 | 139 | ※27000 | ※40000 | 0.5 | 0.05 | 0.005 | 3 |
| 2030 | 1550 | 207 | 159 | 725 | 1790 | 74 | 183 | ※25000 | ※36000 | 1.0 | 0.10 | 0.008 | 4 |
| 2480 | 2070 | 253 | 211 | 805 | 2220 | 82 | 226 | ※23000 | ※33000 | 2.0 | 0.20 | 0.010 | 5 |
| 3850 | 3950 | 395 | 400 | 1080 | 3400 | 110 | 350 | ※19000 | ※25000 | 3.0 | 0.30 | 0.019 | 6 |
| 4500 | 5100 | 460 | 520 | 1380 | 4050 | 141 | 415 | ※15000 | ※20000 | 8.0 | 0.80 | 0.031 | 8 |
| 5050 | 6250 | 515 | 635 | 1690 | 5150 | 172 | 525 | ※12000 | ※16000 | 15.0 | 1.50 | 0.046 | 10 |
| 5050 | 6250 | 515 | 635 | 2120 | 6100 | 216 | 620 | ※12000 | ※16000 | 15.0 | 1.50 | 0.059 | 10 |
| 7500 | 9100 | 765 | 930 | 2620 | 7700 | 267 | 785 | 10000 | ※13000 | 22.0 | 2.20 | 0.087 | 12 |
| 7500 | 9100 | 765 | 930 | 2860 | 8200 | 291 | 835 | 10000 | ※13000 | 22.0 | 2.20 | 0.097 | 12 |
| 11800 | 17300 | 1210 | 1760 | 3200 | 11900 | 325 | 1220 | 8000 | ※11000 | 58.0 | 5.80 | 0.169 | 16 |
| 13600 | 22100 | 1390 | 2250 | 3850 | 14500 | 390 | 1480 | 7000 | 9000 | 87.0 | 8.70 | 0.248 | 18 |
| 20300 | 33000 | 2070 | 3350 | 4700 | 21000 | 480 | 2150 | 6000 | 8000 | 120.0 | 12.00 | 0.386 | 20 |
| 20300 | 33000 | 2070 | 3350 | 5550 | 23300 | 565 | 2370 | 6000 | 8000 | 120.0 | 12.00 | 0.461 | 20 |
| 29100 | 55000 | 2960 | 5650 | 6950 | 34500 | 710 | 3500 | 5000 | 6500 | 220.0 | 22.00 | 0.790 | 24 |
| 29100 | 55000 | 2960 | 5650 | 8050 | 38500 | 820 | 3900 | 5000 | 6500 | 220.0 | 22.00 | 1.040 | 24 |
| 44000 | 86500 | 4500 | 8800 | 9800 | 53000 | 1000 | 5400 | 4000 | 5500 | 450.0 | 45.00 | 1.550 | 30 |
| 44000 | 86500 | 4500 | 8800 | 10400 | 56000 | 1060 | 5750 | 4000 | 5500 | 450.0 | 45.00 | 1.740 | 30 |
| 44000 | 86500 | 4500 | 8800 | 11400 | 59000 | 1160 | 6100 | 4000 | 5500 | 450.0 | 45.00 | 1.950 | 30 |

Notes: Limiting speed of sealed type bearings marked with ※ is approximately 10 000 r/min.

Cam followers stud type truck rollers series KRV

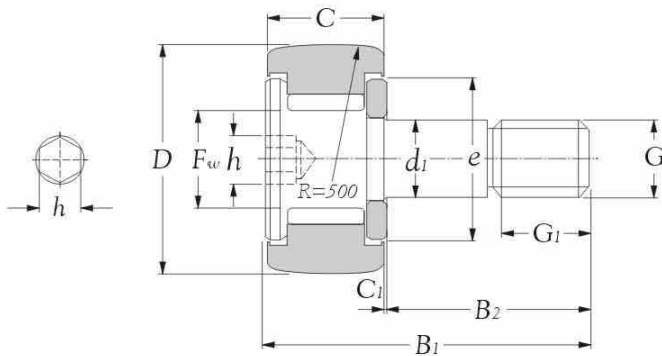

Type KRV (10~19 mm)

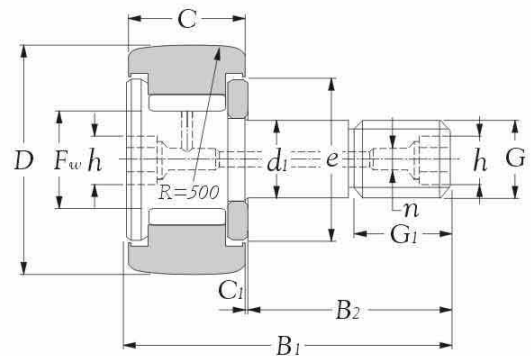

Type KRV (22~26 mm)

| Inner bore D 0/+0.05 mm | Bearing number | | Boundary dimensions | | | | | | | | | | | | |
|----------------------------------|----------------|-----------|---------------------|-----------------------------------|----------------|----------------|----------------|------------|----------------|----------------|-----|----------------|---|------|----|
| | | | C | d ₁ | F _w | B ₁ | B ₂ | G | G ₁ | C ₁ | n | B ₃ | a | e | h |
| 10 | KRV 10 | KRV 10 PP | 7 | 3 ⁰ _{-0.010} | 4.00 | 17 | 9.0 | M 3 X 0.5 | 5.0 | 0.5 | - | - | - | 7.0 | - |
| 12 | KRV 12 | KRV 12 PP | 8 | 4 ⁰ _{-0.012} | 4.80 | 20 | 11.0 | M 4 X 0.7 | 6.0 | 0.5 | - | - | - | 8.5 | - |
| 13 | KRV 13 | KRV 13 PP | 9 | 5 ⁰ _{-0.012} | 5.75 | 23 | 13.0 | M 5 X 0.8 | 7.5 | 0.5 | - | - | - | 9.5 | - |
| 16 | KRV 16 | KRV 16 PP | 11 | 6 ⁰ _{-0.012} | 8.00 | 28 | 16.0 | M 6 X 1.0 | 8.0 | 0.6 | 42) | - | - | 12.0 | - |
| 19 | KRV 19 | KRV 19 PP | 11 | 8 ⁰ _{-0.015} | 10.00 | 32 | 20.0 | M 8 X 1.25 | 10.0 | 0.6 | 42) | - | - | 14.0 | - |
| 22 | KRV 22 | KRV 22 PP | 12 | 10 ⁰ _{-0.015} | 12.00 | 36 | 23.0 | M 10 X 1.0 | 12.0 | 0.6 | 4 | - | - | 17.0 | 5 |
| 26 | KRV 26 | KRV 26 PP | 12 | 10 ⁰ _{-0.015} | 12.00 | 36 | 23.0 | M 10 X 1.0 | 12.0 | 0.6 | 4 | - | - | 17.0 | 5 |
| 30 | KRV 30 | KRV 30 PP | 14 | 12 ⁰ _{-0.018} | 15.00 | 40 | 25.0 | M 12 X 1.5 | 13.0 | 0.6 | 6 | 6 | 3 | 23.0 | 6 |
| 32 | KRV 32 | KRV 32 PP | 14 | 12 ⁰ _{-0.018} | 15.00 | 40 | 25.0 | M 12 X 1.5 | 13.0 | 0.6 | 6 | 6 | 3 | 23.0 | 6 |
| 35 | KRV 35 | KRV 35 PP | 18 | 16 ⁰ _{-0.018} | 18.00 | 52 | 32.5 | M 16 X 1.5 | 17.0 | 0.8 | 6 | 8 | 3 | 27.0 | 8 |
| 40 | KRV 40 | KRV 40 PP | 20 | 18 ⁰ _{-0.018} | 22.00 | 58 | 36.5 | M 18 X 1.5 | 19.0 | 0.8 | 6 | 8 | 3 | 32.0 | 8 |
| 47 | KRV 47 | KRV 47 PP | 24 | 20 ⁰ _{-0.021} | 25.00 | 66 | 40.5 | M 20 X 1.5 | 21.0 | 0.8 | 8 | 9 | 4 | 37.0 | 10 |
| 52 | KRV 52 | KRV 52 PP | 24 | 20 ⁰ _{-0.021} | 25.00 | 66 | 40.5 | M 20 X 1.5 | 21.0 | 0.8 | 8 | 9 | 4 | 37.0 | 10 |
| 62 | KRV 62 | KRV 62 PP | 29 | 24 ⁰ _{-0.021} | 30.00 | 80 | 49.5 | M 24 X 1.5 | 25.0 | 0.8 | 8 | 11 | 4 | 44.0 | 14 |
| 72 | KRV 72 | KRV 72 PP | 29 | 24 ⁰ _{-0.021} | 30.00 | 80 | 49.5 | M 24 X 1.5 | 25.0 | 0.8 | 8 | 11 | 4 | 44.0 | 14 |
| 80 | KRV 80 | KRV 80 PP | 35 | 30 ⁰ _{-0.021} | 38.00 | 100 | 63.0 | M 30 X 1.5 | 32.0 | 1.0 | 8 | 15 | 4 | 53.0 | 14 |
| 90 | KRV 90 | KRV 90 PP | 35 | 30 ⁰ _{-0.021} | 38.00 | 100 | 63.0 | M 30 X 1.5 | 32.0 | 1.0 | 8 | 15 | 4 | 53.0 | 14 |

Cam followers stud type truck rollers series **KRV**

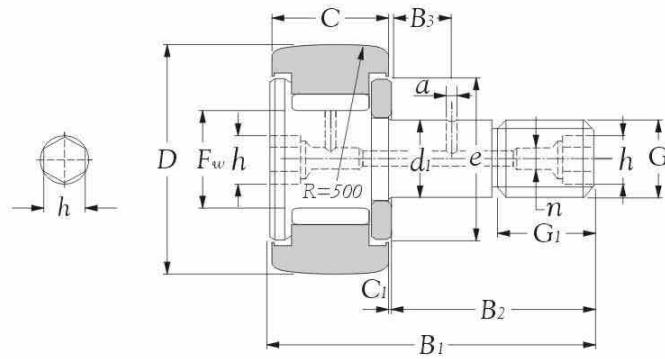

Type KRV (30~90 mm)

| dynamic C | Basic load ratings | | | | Load ratings of truck | | | | Max runout speed | | Maximum tightening torque | | Weight kg(s). | Stud diameter mm |
|--------------|--------------------|--------------|--------------|------------------------------|--------------------------------|--------------------------------|----------------------------------|-----------------|------------------|-------|---------------------------|-------|------------------|---------------------|
| | static Co | dynamic C | static Co | Spherical outer ring N | Cylindrical outer ring N | Spherical outer ring kgf | Cylindrical outer ring kgf | grease r/min | oil | N.m | Kgf.m | | | |
| | N | kgf | kgf | | | | | | | | | | | |
| 2330 | 2400 | 238 | 244 | 560 | 1360 | 57 | 139 | ※25000 | ※32000 | 0.5 | 0.05 | 0.005 | 3 | |
| 3350 | 3550 | 340 | 360 | 725 | 1790 | 74 | 183 | ※20000 | ※27000 | 1.0 | 0.10 | 0.008 | 4 | |
| 4300 | 5050 | 435 | 510 | 805 | 2220 | 82 | 226 | ※17000 | ※22000 | 2.0 | 0.20 | 0.011 | 5 | |
| 6250 | 8900 | 640 | 910 | 1080 | 3400 | 110 | 350 | ※13000 | ※16000 | 3.0 | 0.30 | 0.020 | 6 | |
| 7200 | 11200 | 735 | 1140 | 1380 | 4050 | 141 | 415 | 10000 | ※13000 | 8.0 | 0.80 | 0.032 | 8 | |
| 7900 | 13300 | 810 | 1360 | 1690 | 5150 | 172 | 525 | 8500 | ※11000 | 15.0 | 1.50 | 0.047 | 10 | |
| 7900 | 13300 | 810 | 1360 | 2120 | 6100 | 216 | 620 | 8500 | ※11000 | 15.0 | 1.50 | 0.061 | 10 | |
| 11700 | 19500 | 1190 | 1980 | 2620 | 7700 | 267 | 785 | 6500 | 8500 | 22.0 | 2.20 | 0.089 | 12 | |
| 11700 | 19500 | 1190 | 1980 | 2860 | 8200 | 291 | 835 | 6500 | 8500 | 22.0 | 2.20 | 0.100 | 12 | |
| 17200 | 33000 | 1750 | 3400 | 3200 | 11900 | 325 | 1220 | 5500 | 7000 | 58.0 | 5.80 | 0.172 | 16 | |
| 18900 | 40500 | 1930 | 4150 | 3850 | 14500 | 390 | 1480 | 4500 | 6000 | 87.0 | 8.70 | 0.252 | 18 | |
| 28300 | 60000 | 2890 | 6100 | 4700 | 21000 | 480 | 2150 | 4000 | 5000 | 120.0 | 12.00 | 0.390 | 20 | |
| 28300 | 60000 | 2890 | 6100 | 5550 | 23300 | 565 | 2370 | 4000 | 5000 | 120.0 | 12.00 | 0.465 | 20 | |
| 39000 | 96500 | 3950 | 9850 | 6950 | 34500 | 710 | 3500 | 3300 | 4500 | 220.0 | 22.00 | 0.800 | 24 | |
| 39000 | 96500 | 3950 | 9850 | 8050 | 38500 | 820 | 3900 | 3300 | 4500 | 220.0 | 22.00 | 1.050 | 24 | |
| 57000 | 144000 | 5800 | 14700 | 9800 | 53000 | 1000 | 5400 | 2600 | 3500 | 450.0 | 45.00 | 1.560 | 30 | |
| 57000 | 144000 | 5800 | 14700 | 11400 | 59000 | 1160 | 6100 | 2600 | 3500 | 450.0 | 45.00 | 1.970 | 30 | |

Notes: Limiting speed of sealed type bearings marked with ※ is approximately 10 000 r/min.

Cam followers stud type truck rollers (multi-row cylindrical roller bearings)
series NUKR

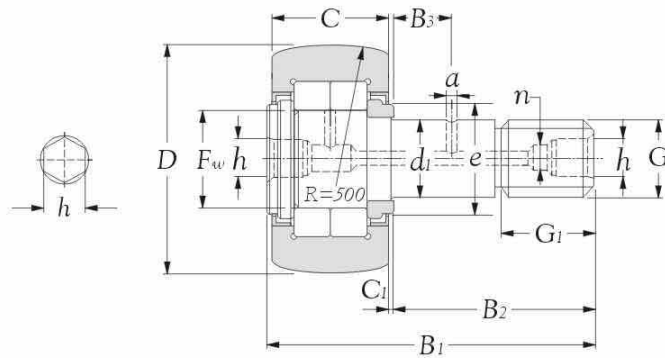

Type NUKR (D<100 mm) (Double row type full complement with seals)

| Inner bore D 0 ^{+0.05} mm | Bearing number | Boundary dimensions | | | | | | | | | | | | | |
|---|----------------|---------------------|-----------------------------------|----------------|----------------|----------------|------------|----------------|----------------|---|----------------|---|----|----|--|
| | | C | d ₁ | F _w | B ₁ | B ₂ | G | G ₁ | C ₁ | n | B ₃ | a | e | h | |
| 35 | NUKR 35 | 18 | 16 ⁰ _{-0.018} | 19.0 | 52 | 32.5 | M 16 X 1.5 | 17 | 0.8 | 6 | 8 | 3 | 21 | 8 | |
| 40 | NUKR 40 | 20 | 18 ⁰ _{-0.018} | 21.5 | 58 | 36.5 | M 18 X 1.5 | 19 | 0.8 | 6 | 8 | 3 | 23 | 8 | |
| 47 | NUKR 47 | 24 | 20 ⁰ _{-0.021} | 25.5 | 66 | 40.5 | M 20 X 1.5 | 21 | 0.8 | 8 | 9 | 4 | 27 | 10 | |
| 52 | NUKR 52 | 24 | 20 ⁰ _{-0.021} | 30.0 | 66 | 40.5 | M 20 X 1.5 | 21 | 0.8 | 8 | 9 | 4 | 31 | 10 | |
| 62 | NUKR 62 | 29 | 24 ⁰ _{-0.021} | 35.0 | 80 | 49.5 | M 24 X 1.5 | 25 | 0.8 | 8 | 11 | 4 | 38 | 14 | |
| 72 | NUKR 72 | 29 | 24 ⁰ _{-0.021} | 41.5 | 80 | 49.5 | M 24 X 1.5 | 25 | 0.8 | 8 | 11 | 4 | 44 | 14 | |
| 80 | NUKR 80 | 35 | 30 ⁰ _{-0.021} | 47.5 | 100 | 63.0 | M 30 X 1.5 | 32 | 1.0 | 8 | 15 | 4 | 51 | 14 | |
| 90 | NUKR 90 | 35 | 30 ⁰ _{-0.021} | 47.5 | 100 | 63.0 | M 30 X 1.5 | 32 | 1.0 | 8 | 15 | 4 | 51 | 14 | |

**Cam followers stud type truck rollers (multi-row cylindrical roller bearings)
series NUKR**

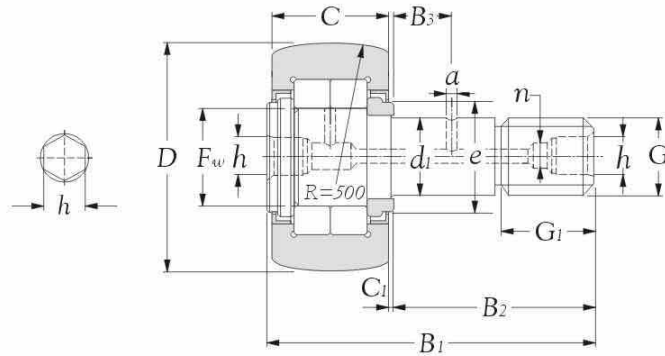

Type NUKR (D<100 mm) (Double row type full complement with seals)

| Basic load ratings | | | | Load ratings of truck | | | | Max runout speed grease r/min | Maximum tightening torque | | Weight kg (s) | Stud diameter mm |
|--------------------|--------------|--------------|--------------|-------------------------|---------------------------|-------------------------|---------------------------|-------------------------------------|------------------------------|-------|------------------|------------------------|
| dynamic C | static Co | dynamic C | static Co | Spherical outer ring | Cylindrical outer ring | Spherical outer ring | Cylindrical outer ring | | N.m | Kgf.m | | |
| N | | kgf | | N | | kgf | | | | | | |
| 22300 | 25700 | 2280 | 2620 | 3200 | 11900 | 325 | 1220 | 5500 | 58 | 5.8 | 0.165 | 16 |
| 24100 | 29100 | 2450 | 2970 | 3850 | 14500 | 390 | 1480 | 4700 | 87 | 8.7 | 0.242 | 18 |
| 38500 | 48000 | 3950 | 4900 | 4700 | 21000 | 480 | 2150 | 4000 | 120 | 12.0 | 0.380 | 20 |
| 42500 | 57500 | 4350 | 5850 | 5550 | 23300 | 565 | 2370 | 3300 | 120 | 12.0 | 0.450 | 20 |
| 56500 | 72500 | 5750 | 7400 | 6950 | 34500 | 710 | 3500 | 2900 | 220 | 22.0 | 0.795 | 24 |
| 62000 | 85500 | 6350 | 8700 | 8050 | 38500 | 820 | 3900 | 2400 | 220 | 22.0 | 1.010 | 24 |
| 101000 | 151000 | 10300 | 15400 | 9800 | 53000 | 1000 | 5400 | 2100 | 450 | 45.0 | 1.540 | 30 |
| 101000 | 151000 | 10300 | 15400 | 11400 | 59000 | 1160 | 6100 | 2100 | 450 | 45.0 | 1.960 | 30 |



Components



TECHNICAL SUPPLEMENT

T142

PRODUCT INFORMATION

P143 - 153

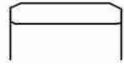

IR

P143 - 153

1. Bearing materials

KSM Inner Rings are available in the series IR, whose boundary dimensions are in metric measurements. Both ends of the inner ring are lead-chamfered for easier assembly. Inner rings marked with an asterisk have a slight chamfer in order to provide greater axial displacement. **KSM** Also offers inner rings having a lubrication hole at their midpoint (suffix D). For much greater running accuracy, the raceway of the inner ring can be finish-ground after the inner ring has been mounted to a shaft. To accommodate this need, **KSM** can supply an inner ring whose raceway surface allows for grinding. For details, contact **KSM** Engineering.

2. Interpreting inner ring numbers

The inner ring numbers of **KSM** Inner Rings comprise of a series number (IR), dimension code inside dia. (D) \times raceway dia. (F) \times width (B), and a suffix.

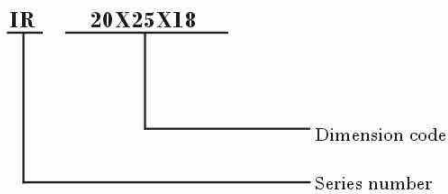
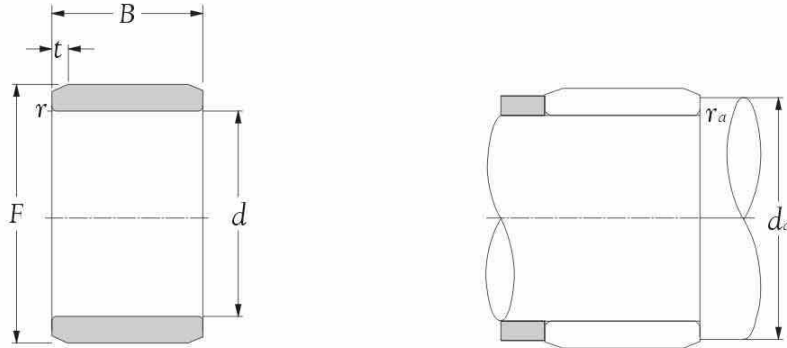

Fig. 1

Inner rings series IR



| Inner bore <i>d</i> mm | Bearing number | Principal dimensions | | | | Abutment dimensions | | Weight kg. |
|------------------------------|----------------|-----------------------------------|----------------|--|----------|-----------------------------|-------------------------------------|---------------|
| | | <i>F</i> ¹⁾ | <i>B</i> mm | <i>r</i> _s mm ²⁾ | <i>t</i> | <i>d</i> _a mm | <i>r</i> _{as} max mm | |
| 5 | IR 5x7x10 | 7 ⁰ _{-0.006} | 10.0 | 0.15 | 1 | 6.2 | 0.15 | 0.0014 |
| 5 | IR 5x8x12 | 8 ⁰ _{-0.006} | 12.0 | 0.30 | 1 | 7.0 | 0.30 | 0.0028 |
| 5 | IR 5x8x16 | 8 ⁰ _{-0.006} | 16.0 | 0.30 | - | 7.0 | 0.30 | 0.0038 |
| 6 | IR 6x8x10 | 8 ⁰ _{-0.006} | 10.0 | 0.15 | 1 | 7.2 | 0.15 | 0.0017 |
| 6 | IR 6x9x12 | 9 ⁰ _{-0.006} | 12.0 | 0.30 | 1 | 8.0 | 0.30 | 0.0032 |
| 6 | IR 6x9x16 | 9 ⁰ _{-0.006} | 16.0 | 0.30 | 1 | 8.0 | 0.30 | 0.0043 |
| 6 | IR 6x10x10 | 10 ⁰ _{-0.006} | 10.0 | 0.30 | 1 | 8.0 | 0.30 | 0.0037 |
| 6 | IR 6x10x12 | 10 ⁰ _{-0.006} | 12.0 | 0.30 | - | 8.0 | 0.30 | 0.0046 |
| 6 | IR 6x10x13 | 10 ⁰ _{-0.006} | 13.0 | 0.30 | 1 | 8.0 | 0.30 | 0.0050 |
| 7 | IR 7x9x10 | 9 ⁰ _{-0.006} | 10.0 | 0.15 | 1 | 8.2 | 0.15 | 0.0019 |
| 7 | IR 7x10x10.5 | 10 ⁰ _{-0.006} | 10.5 | 0.30 | 1 | 9.0 | 0.30 | 0.0031 |
| 7 | IR 7x10x12 | 10 ⁰ _{-0.006} | 12.0 | 0.30 | 1 | 9.0 | 0.30 | 0.0036 |
| 7 | IR 7x10x16 | 10 ⁰ _{-0.006} | 16.0 | 0.30 | 1 | 9.0 | 0.30 | 0.0049 |
| 7 | IR 7x12x16 | 12 ⁰ _{-0.008} | 16.0 | 0.30 | 1 | 9.0 | 0.30 | 0.0093 |
| 8 | IR 8x10x11 | 10 ⁰ _{-0.006} | 11.0 | 0.15 | 1 | 9.2 | 0.15 | 0.0024 |
| 8 | IR 8x12x10 | 12 ⁰ _{-0.006} | 10.0 | 0.30 | 1 | 10.0 | 0.30 | 0.0048 |
| 8 | IR 8x12x10.5 | 12 ⁰ _{-0.008} | 10.5 | 0.30 | 1 | 10.0 | 0.30 | 0.0050 |
| 8 | IR 8x12x12 | 12 ⁰ _{-0.008} | 12.0 | 0.30 | - | 10.0 | 0.30 | 0.0057 |
| 8 | IR 8x12x12.5 | 12 ⁰ _{-0.008} | 12.5 | 0.30 | 1 | 10.0 | 0.30 | 0.0059 |
| 8 | IR 8x14x16 | 14 ⁰ _{-0.008} | 16.0 | 0.30 | 1 | 10.0 | 0.30 | 0.0130 |
| 9 | IR 9x12x11 | 12 ⁰ _{-0.008} | 11.0 | 0.30 | 1 | 11.0 | 0.30 | 0.0041 |
| 9 | IR 9x12x12 | 12 ⁰ _{-0.008} | 12.0 | 0.30 | 1 | 11.0 | 0.30 | 0.0045 |
| 9 | IR 9x12x16 | 12 ⁰ _{-0.008} | 16.0 | 0.30 | 1 | 11.0 | 0.30 | 0.0061 |
| 9 | IR 9x15x16 | 15 ⁰ _{-0.008} | 16.0 | 0.30 | 1 | 11.0 | 0.30 | 0.0140 |
| 10 | IR 10x13x12.5 | 13 ⁰ _{-0.008} | 12.5 | 0.30 | 1 | 12.0 | 0.30 | 0.0052 |
| 10 | IR 10x14x12 | 14 ⁰ _{-0.008} | 12.0 | 0.30 | 1 | 12.0 | 0.30 | 0.0073 |
| 10 | IR 10x14x13 | 14 ⁰ _{-0.008} | 13.0 | 0.30 | 1 | 12.0 | 0.30 | 0.0074 |
| 10 | IR 10x14x14 | 14 ⁰ _{-0.008} | 14.0 | 0.30 | - | 12.0 | 0.30 | 0.0080 |
| 10 | IR 10x14x16 | 14 ⁰ _{-0.008} | 16.0 | 0.30 | - | 12.0 | 0.30 | 0.0092 |
| 10 | IR 10x14x20 | 14 ⁰ _{-0.008} | 20.0 | 0.30 | 1.0 | 12.0 | 0.30 | 0.0120 |
| 10 | IR 10x15x15.5 | 15 ⁰ _{-0.008} | 15.5 | 0.30 | 1.0 | 12.0 | 0.30 | 0.0120 |

Notes: 1) The tolerance for this dimension provides regular clearance when an inner ring is combined with a needle roller bearing that lacks an inner ring.

2) These values are the allowable minimum dimensions of the chamfer dimension *r*.

Inner rings series IR

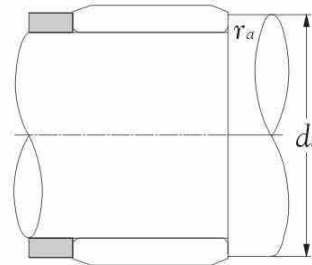
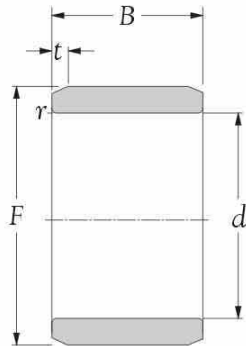

| Inner bore <i>d</i> mm | Bearing number | Principal dimensions | | | | Abutment dimensions | | Weight kg. |
|------------------------------|----------------|-----------------------------------|----------|---------------------------------------|----------|----------------------------|--|---------------|
| | | <i>F</i> ¹⁾ | <i>B</i> | <i>r_s</i> mm ²⁾ | <i>t</i> | <i>d_a</i> mm | <i>r_{as}</i> mm <i>r_{as}</i> <i>max</i> | |
| 10 | IR 10x15x20.5 | 15 ⁰ _{-0.008} | 20.5 | 0.3 | 1.0 | 12 | 0.3 | 0.0150 |
| 10 | IR 10x16x16 | 16 ⁰ _{-0.008} | 16.0 | 0.3 | 1.0 | 12 | 0.3 | 0.0150 |
| 12 | IR 12x15x12 | 15 ⁰ _{-0.008} | 12.0 | 0.3 | 1.0 | 14 | 0.3 | 0.0058 |
| 12 | IR 12x15x12.5 | 15 ⁰ _{-0.008} | 12.5 | 0.3 | 1.0 | 14 | 0.3 | 0.0061 |
| 12 | IR 12x15x16 | 15 ⁰ _{-0.008} | 16.0 | 0.3 | 1.0 | 14 | 0.3 | 0.0078 |
| 12 | IR 12x15x16.5 | 15 ⁰ _{-0.008} | 16.5 | 0.3 | - | 14 | 0.3 | 0.0080 |
| 12 | IR 12x15x22.5 | 15 ⁰ _{-0.008} | 22.5 | 0.3 | - | 14 | 0.3 | 0.0110 |
| 12 | IR 12x16x12 | 16 ⁰ _{-0.008} | 12.0 | 0.3 | 1.5 | 14 | 0.3 | 0.0079 |
| 12 | IR 12x16x13 | 16 ⁰ _{-0.008} | 13.0 | 0.3 | 1.5 | 14 | 0.3 | 0.0087 |
| 12 | IR 12x16x14 | 16 ⁰ _{-0.008} | 14.0 | 0.3 | - | 14 | 0.3 | 0.0095 |
| 12 | IR 12x16x16 | 16 ⁰ _{-0.008} | 16.0 | 0.3 | 1.5 | 14 | 0.3 | 0.0110 |
| 12 | IR 12x16x20 | 16 ⁰ _{-0.008} | 20.0 | 0.3 | 1.5 | 14 | 0.3 | 0.0140 |
| 12 | IR 12x16x22 | 16 ⁰ _{-0.008} | 22.0 | 0.3 | 1.5 | 14 | 0.3 | 0.0150 |
| 12 | IR 12x17x20.5 | 17 ⁰ _{-0.008} | 20.5 | 0.3 | 1.5 | 14 | 0.3 | 0.0190 |
| 12 | IR 12x17x25.5 | 17 ⁰ _{-0.008} | 25.5 | 0.3 | 1.5 | 14 | 0.3 | 0.0240 |
| 12 | IR 12x18x16 | 18 ⁰ _{-0.008} | 16.0 | 0.3 | 1.5 | 14 | 0.3 | 0.0180 |
| 14 | IR 14x17x17 | 17 ⁰ _{-0.008} | 17.0 | 0.3 | 1.5 | 16 | 0.3 | 0.0095 |
| 15 | IR 15x18x12.5 | 18 ⁰ _{-0.008} | 12.5 | 0.3 | 1.5 | 17 | 0.3 | 0.0072 |
| 15 | IR 15x18x16 | 18 ⁰ _{-0.008} | 16.0 | 0.3 | 1.5 | 17 | 0.3 | 0.0093 |
| 15 | IR 15x18x16.5 | 18 ⁰ _{-0.008} | 16.5 | 0.3 | 1.5 | 17 | 0.3 | 0.0096 |
| 15 | IR 15x18x17.5 | 18 ⁰ _{-0.008} | 17.5 | 0.3 | 1.5 | 17 | 0.3 | 0.0100 |
| 15 | IR 15x18x20.5 | 18 ⁰ _{-0.008} | 20.5 | 0.3 | 1.5 | 17 | 0.3 | 0.0120 |
| 15 | IR 15x18x25.5 | 18 ⁰ _{-0.008} | 25.5 | 0.3 | 1.5 | 17 | 0.3 | 0.0150 |
| 15 | IR 15x19x16 | 19 ⁰ _{-0.009} | 16.0 | 0.3 | 1.5 | 17 | 0.3 | 0.0130 |
| 15 | IR 15x19x20 | 19 ⁰ _{-0.009} | 20.0 | 0.3 | 1.5 | 17 | 0.3 | 0.0160 |
| 15 | IR 15x20x12 | 20 ⁰ _{-0.009} | 12.0 | 0.3 | 1.5 | 17 | 0.3 | 0.012 |
| 15 | IR 15x20x13 | 20 ⁰ _{-0.009} | 13.0 | 0.3 | 1.5 | 17 | 0.3 | 0.014 |
| 15 | IR 15x20x14 | 20 ⁰ _{-0.009} | 14.0 | 0.3 | - | 17 | 0.3 | 0.015 |
| 15 | IR 15x20x18 | 20 ⁰ _{-0.009} | 18.0 | 0.3 | 1.5 | 17 | 0.3 | 0.019 |
| 15 | IR 15x20x20.5 | 20 ⁰ _{-0.009} | 20.5 | 0.3 | 1.5 | 17 | 0.3 | 0.021 |
| 15 | IR 15x20x23 | 20 ⁰ _{-0.009} | 23.0 | 0.3 | - | 17 | 0.3 | 0.024 |

Notes: 1) The tolerance for this dimension provides regular clearance when an inner ring is combined with a needle roller bearing that lacks an inner ring.

2) These values are the allowable minimum dimensions of the chamfer dimension *r*.

Inner rings series IR

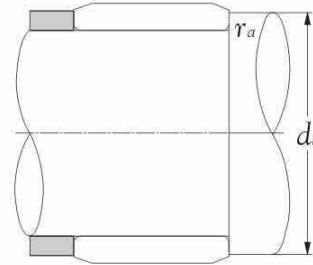
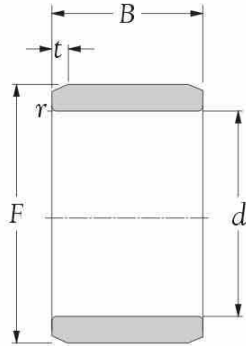

| Inner bore d mm | Bearing number | Principal dimensions | | | | Abutment dimensions | | Weight kg(s). |
|-------------------------|----------------|---|-----|-----------------------|-----|---------------------|----------------------------------|------------------|
| | | $F^{1)}$ | B | $r_s \text{ mm}^{2)}$ | t | d_a mm | r_{as} $r_{as \text{ max}}$ | |
| 120 | IR 120x130x30 | 130 ⁰ _{-0.018} | 30 | 1.0 | 2.2 | 125.0 | 1.0 | 0.440 |
| 120 | IR 120x130x40 | 130 ⁰ _{-0.018} | 40 | 1.1 | 2.5 | 126.5 | 1.0 | 0.590 |
| 120 | IR 120x135x40 | 135 ⁰ _{-0.018} | 40 | 2.0 | 2.5 | 129.0 | 2.0 | 0.870 |
| 120 | IR 120x135x45 | 135 ⁰ _{-0.018} | 45 | 1.1 | 2.5 | 126.5 | 1.0 | 0.980 |
| 120 | IR 120x135x60 | 135 ⁰ _{-0.018} | 60 | 1.1 | 2.5 | 126.5 | 1.0 | 1.250 |
| 130 | IR 130x145x32 | 145 ⁰ _{-0.018} | 32 | 1.5 | 3.0 | 138.0 | 1.5 | 0.780 |
| 130 | IR 130x145x35 | 145 ⁰ _{-0.018} | 35 | 1.1 | 3.0 | 136.5 | 1.0 | 0.855 |
| 130 | IR 130x145x42 | 145 ⁰ _{-0.018} | 42 | 1.5 | 3.0 | 138.0 | 1.5 | 1.050 |
| 130 | IR 130x150x50 | 150 ⁰ _{-0.018} | 50 | 1.5 | 3.0 | 138.0 | 1.5 | 1.690 |
| 130 | IR 130x150x52 | 150 ⁰ _{-0.018} | 52 | 2.0 | 3.0 | 139.0 | 2.0 | 1.750 |
| 130 | IR 130x150x67 | 150 ⁰ _{-0.018} | 67 | 1.5 | 3.0 | 138.0 | 1.5 | 2.250 |
| 140 | IR 140x155x32 | 155 ⁰ _{-0.018} | 32 | 1.5 | 3.0 | 148.0 | 1.5 | 0.840 |
| 140 | IR 140x155x35 | 155 ⁰ _{-0.018} | 35 | 1.1 | 3.0 | 146.5 | 1.0 | 0.917 |
| 140 | IR 140x155x42 | 155 ⁰ _{-0.018} | 42 | 1.5 | 3.0 | 148.0 | 1.5 | 1.100 |
| 140 | IR 140x160x50 | 160 ⁰ _{-0.018} | 50 | 1.5 | 3.0 | 148.0 | 1.5 | 1.700 |
| 140 | IR 140x160x52 | 160 ⁰ _{-0.018} | 52 | 2.0 | 3.0 | 149.0 | 2.0 | 1.780 |
| 140 | IR 140x160x67 | 160 ⁰ _{-0.018} | 67 | 1.5 | 3.0 | 148.0 | 1.5 | 2.300 |
| 150 | IR 150x165x32 | 165 ^{-0.017} _{-0.085} | 32 | 1.5 | 3.0 | 158.0 | 1.5 | 0.900 |
| 150 | IR 150x165x40 | 165 ^{-0.017} _{-0.085} | 40 | 1.1 | 3.0 | 156.5 | 1.0 | 1.120 |
| 150 | IR 150x165x42 | 165 ^{-0.017} _{-0.085} | 42 | 1.5 | 3.0 | 158.0 | 1.5 | 1.180 |
| 150 | IR 150x170x52 | 170 ^{-0.017} _{-0.085} | 52 | 2.0 | 3.0 | 159.0 | 2.0 | 2.000 |
| 150 | IR 150x170x60 | 170 ^{-0.017} _{-0.085} | 60 | 2.0 | 3.0 | 159.0 | 2.0 | 2.350 |
| 160 | IR 160x175x40 | 175 ^{-0.017} _{-0.085} | 40 | 1.1 | 3.0 | 166.5 | 1.0 | 1.200 |
| 160 | IR 160x180x60 | 180 ^{-0.017} _{-0.085} | 60 | 2.0 | 3.0 | 169.0 | 2.0 | 2.500 |
| 170 | IR 170x185x45 | 185 ^{-0.018} _{-0.043} | 45 | 1.1 | 3.0 | 176.5 | 1.0 | 1.450 |
| 170 | IR 170x190x60 | 190 ^{-0.018} _{-0.043} | 60 | 2.0 | 3.0 | 179.0 | 2.0 | 2.650 |
| 180 | IR 180x195x45 | 195 ^{-0.018} _{-0.043} | 45 | 1.1 | 3.0 | 186.5 | 1.0 | 1.510 |
| 180 | IR 180x205x69 | 205 ^{-0.018} _{-0.043} | 69 | 2.0 | 3.0 | 189.0 | 2.0 | 4.100 |
| 190 | IR 190x210x50 | 210 ^{-0.020} _{-0.050} | 50 | 1.5 | 3.5 | 198.0 | 1.5 | 2.410 |
| 190 | IR 190x215x69 | 215 ^{-0.020} _{-0.050} | 69 | 2.0 | 3.5 | 199.0 | 2.0 | 4.100 |
| 200 | IR 200x220x50 | 220 ^{-0.020} _{-0.050} | 50 | 1.5 | 3.5 | 208.0 | 1.5 | 2.490 |

Notes: 1) The tolerance for this dimension provides regular clearance when an inner ring is combined with a needle roller bearing that lacks an inner ring.

2) These values are the allowable minimum dimensions of the chamfer dimension r .

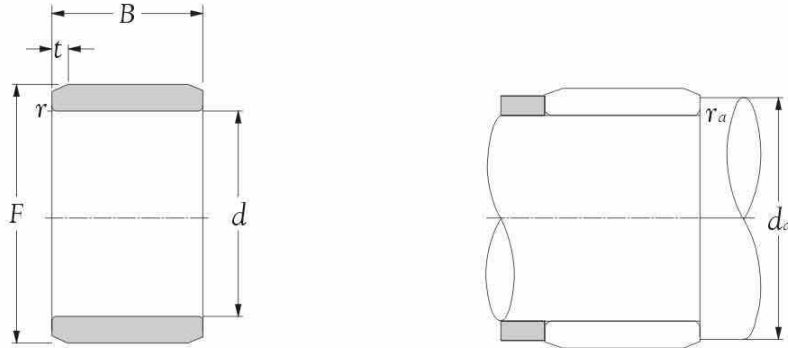

| Inner bore <i>d</i> mm | Bearing number | Principal dimensions | | | | Abutment dimensions | | Weight kgs. |
|------------------------------|----------------|----------------------------------|----------|--|----------|--------------------------|----------------------------|----------------|
| | | <i>F</i> ¹⁾ | <i>B</i> | <i>r</i> _s mm ²⁾ | <i>t</i> | <i>d</i> _a mm | <i>r</i> _{as} max | |
| 200 | IR 200x225x80 | 225 ^{-0.020 -0.050} | 80 | 2.1 | 3.5 | 211 | 2.0 | 5.100 |
| 220 | IR 220x240x50 | 240 ^{-0.088 -0.068} | 50 | 1.5 | 3.5 | 228 | 1.5 | 2.750 |
| 220 | IR 220x245x80 | 245 ^{-0.088 -0.068} | 80 | 2.1 | 3.5 | 231 | 2.0 | 5.700 |
| 240 | IR 240x265x60 | 265 ^{-0.027 -0.069} | 60 | 2.0 | 3.5 | 249 | 2.0 | 4.600 |
| 240 | IR 240x265x80 | 265 ^{-0.027 -0.069} | 80 | 2.1 | 3.5 | 251 | 2.0 | 6.300 |
| 260 | IR 260x285x60 | 285 ^{-0.064 -0.092} | 60 | 2.0 | 4.0 | 269 | 2.0 | 4.980 |
| 260 | IR 260x290x100 | 290 ^{-0.064 -0.092} | 100 | 2.1 | 4.0 | 271 | 2.0 | 10.000 |
| 280 | IR 280x305x69 | 305 ^{-0.064 -0.092} | 69 | 2.0 | 4.0 | 289 | 2.0 | 6.200 |
| 280 | IR 280x310x100 | 310 ^{-0.064 -0.092} | 100 | 2.1 | 4.0 | 291 | 2.0 | 10.800 |
| 300 | IR 300x330x80 | 330 ^{-0.062 -0.098} | 80 | 2.1 | 4.0 | 311 | 2.0 | 9.300 |
| 300 | IR 300x340x118 | 340 ^{-0.062 -0.098} | 118 | 3.0 | 4.0 | 313 | 2.5 | 18.500 |
| 320 | IR 320x350x80 | 350 ^{-0.062 -0.098} | 80 | 2.1 | 5.0 | 331 | 2.0 | 9.800 |
| 320 | IR 320x360x118 | 360 ^{-0.062 -0.098} | 118 | 3.0 | 5.0 | 333 | 2.5 | 20.000 |
| 340 | IR 340x370x80 | 370 ^{-0.062 -0.098} | 80 | 2.1 | 5.0 | 351 | 2.0 | 10.100 |
| 340 | IR 340x380x118 | 380 ^{-0.062 -0.098} | 118 | 3.0 | 5.0 | 353 | 2.5 | 22.000 |
| 360 | IR 360x390x80 | 390 ^{-0.090 -0.126} | 80 | 2.1 | 5.0 | 371 | 2.0 | 10.900 |
| 360 | IR 360x400x118 | 400 ^{-0.090 -0.126} | 118 | 3.0 | 5.0 | 373 | 2.5 | 22.000 |
| 380 | IR 380x415x100 | 415 ^{-0.080 -0.120} | 100 | 2.1 | 5.0 | 391 | 2.0 | 18.500 |
| 380 | IR 380x430x140 | 430 ^{-0.080 -0.120} | 140 | 4.0 | 5.0 | 396 | 3.0 | 35.000 |
| 400 | IR 400x450x140 | 450 ^{-0.080 -0.120} | 140 | 4.0 | 5.0 | 416 | 3.0 | 36.500 |
| 420 | IR 420x470x140 | 470 ^{-0.105 -0.145} | 140 | 4.0 | 5.0 | 436 | 3.0 | 38.200 |
| 440 | IR 440x490x160 | 490 ^{-0.105 -0.145} | 160 | 4.0 | 5.0 | 456 | 3.0 | 46.500 |

Notes: 1) The tolerance for this dimension provides regular clearance when an inner ring is combined with a needle roller bearing that lacks an inner ring.

2) These values are the allowable minimum dimensions of the chamfer dimension *r*.



Seals

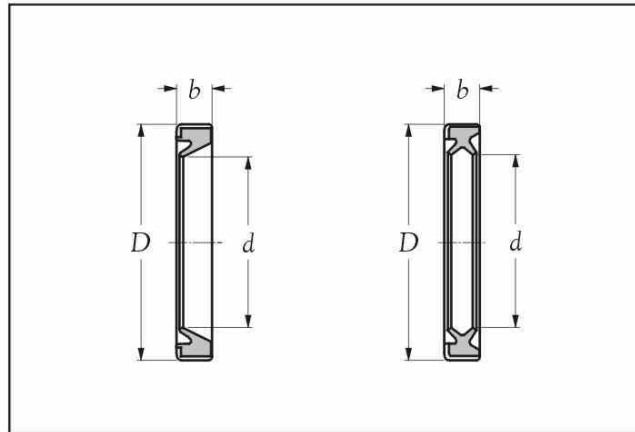

TECHNICAL SUPPLEMENT

T156 - 157

PRODUCT INFORMATION

P158 - 159



G

P158 - 159



SD

P158 - 159

1. Seals

Seals for needle roller bearings are special seals having a low cross-sectional height to accommodate needle roller bearings. These steel plate-reinforced synthetic rubber contact seals should be used within a standard operating temperature range of -25 to 120 °C; the seals should not be used in excess of 100 °C or continuous operation. Consult **KSM Engineering** if you are considering an application involving special operating conditions including operating temperature of 120 °C or higher.

2. Seal types

Seals for needle roller bearings are available in the series G, which has a single lip, and the series SD, which has a double lip. For special operating conditions, such as an operating temperature exceeding 120 °C, consult **KSM Engineering**. Where good seal seating and lubricating conditions are present, the maximum allowable peripheral velocity is 10m/s for the single-lip series G, and 6 m/s for the double lip series SD.



Fig. 1 Series G

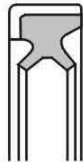

Fig. 2 Series SD

3. Interpreting seal numbers

Seal numbers comprise a series number (G or SD) and a dimension code (inside diameter X outside diameter X width.)

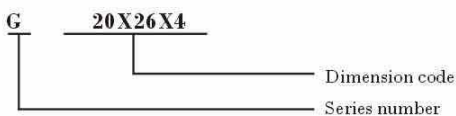

Fig. 3

4. Mounting practices

To achieve a reliable seal, the seal seating must be hardened and finish-ground. If the raceway surface of an inner ring is used as the seal seat, an extended inner ring should be used. To prevent the seal lip and outside surface of the seal from being damaged during mounting, the shaft end or housing end should be tapered (Fig.4). If the shaft end lacks a taper or rounding, use of the mounting jig as shown in Fig.5 is recommended. Sufficient interference between the seal and housing will be obtained from an ordinary housing tolerance of S7 to R7.

To lubricate the lip, apply lubricant to the lip before mounting the seal.

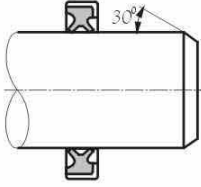

Fig. 4

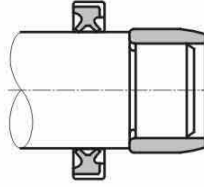

Fig. 5

5. Typical seal applications

Fig. 6 to 8 illustrate typical designs of seals for needle roller bearings.

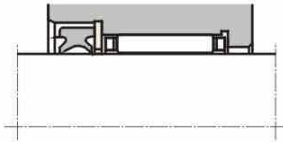

Fig. 6

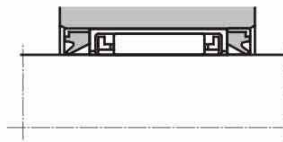

Fig. 7

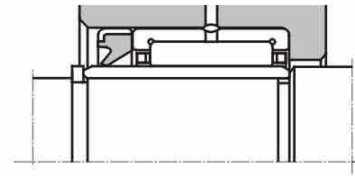
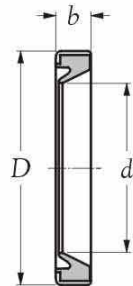
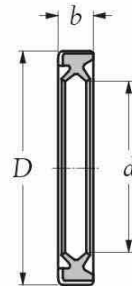

Fig. 8



Type G



Type SD

| Inner bore <i>d</i> mm | Bearing number | Boundary dimensions | | Weight | |
|------------------------------|----------------|--|--|-------------|------|
| | | <i>D</i> ¹⁾ mm | <i>b</i> ^{+0.2} ₀ | G kg(s). | SD |
| 4 | G 4x8x2 | 8 ^{+0.081} _{+0.023} | 2 | 0.18 | - |
| 5 | G 5x9x3 | 9 ^{+0.081} _{+0.023} | 2 | 0.19 | - |
| 5 | G 5x10x2 | 10 ^{+0.081} _{+0.023} | 2 | 0.22 | - |
| 6 | G 6x10x2 | 10 ^{+0.081} _{+0.023} | 2 | 0.21 | - |
| 6 | G 6x12x2 | 12 ^{+0.098} _{+0.028} | 2 | 0.38 | - |
| 7 | G 7x11x2 | 11 ^{+0.098} _{+0.028} | 2 | 0.25 | - |
| 7 | G 7x14x2 | 14 ^{+0.098} _{+0.028} | 2 | 0.52 | - |
| 8 | G 8x12x3 | 12 ^{+0.098} _{+0.028} | 3 | 0.41 | - |
| 8 | G 8x15x3 | 15 ^{+0.098} _{+0.028} | 3 | 0.74 | - |
| 9 | G 9x13x3 | 13 ^{+0.098} _{+0.028} | 3 | 0.44 | - |
| 9 | G 9x16x3 | 16 ^{+0.098} _{+0.028} | 3 | 0.69 | - |
| 10 | G 10x14x3 | 14 ^{+0.098} _{+0.028} | 3 | 0.50 | - |
| 10 | G 10x17x3 | 17 ^{+0.098} _{+0.028} | 3 | 0.87 | - |
| 12 | G 12x16x3 | 16 ^{+0.098} _{+0.028} | 3 | 0.56 | - |
| 12 | G 12x18x3 | 18 ^{+0.098} _{+0.028} | 3 | 0.86 | - |
| 12 | G 12x19x3 | 19 ^{+0.119} _{+0.085} | 3 | 0.94 | - |
| 13 | G 13x19x3 | 19 ^{+0.119} _{+0.085} | 3 | 0.87 | - |
| 14 | G 14x20x3 | 20 ^{+0.119} _{+0.085} | 3 | 0.96 | 0.99 |
| 14 | G 14x21x3 | 21 ^{+0.119} _{+0.085} | 3 | 1.10 | 1.10 |
| 14 | G 14x22x3 | 22 ^{+0.119} _{+0.085} | 3 | 1.30 | 1.30 |
| 15 | G 15x21x3 | 21 ^{+0.119} _{+0.085} | 3 | 1.00 | 1.00 |
| 15 | G 15x23x3 | 23 ^{+0.119} _{+0.085} | 3 | 1.30 | 1.30 |
| 16 | G 16x22x3 | 22 ^{+0.119} _{+0.085} | 3 | 1.30 | 1.10 |
| 16 | G 16x24x3 | 24 ^{+0.119} _{+0.085} | 3 | 1.30 | 1.30 |
| 16 | G 16x25x3 | 25 ^{+0.119} _{+0.085} | 3 | 1.60 | 1.60 |
| 17 | G 17x23x3 | 23 ^{+0.119} _{+0.085} | 3 | 1.30 | 1.10 |
| 17 | G 17x25x3 | 25 ^{+0.119} _{+0.085} | 3 | 1.50 | 1.40 |
| 18 | G 18x24x3 | 24 ^{+0.119} _{+0.085} | 3 | 1.20 | 1.20 |
| 18 | G 18x26x4 | 26 ^{+0.119} _{+0.085} | 4 | 1.80 | 1.80 |
| 19 | G 19x27x4 | 27 ^{+0.119} _{+0.085} | 4 | 2.00 | 1.90 |
| 20 | G 20x26x4 | 26 ^{+0.119} _{+0.085} | 4 | 1.80 | 1.80 |
| 20 | G 20x28x4 | 28 ^{+0.119} _{+0.085} | 4 | 2.10 | 2.10 |

Notes: 1) The tolerance of the outside diameter is an average of two measurements taken at equally spaced points on the outside surface.



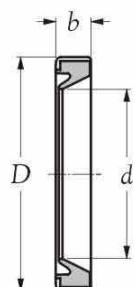

Type G

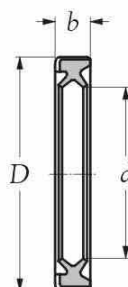

Type SD

| Inner bore <i>d</i> mm | Bearing number | | Boundary dimensions | | Weight | |
|------------------------------|----------------|------------|--|--|-----------|------|
| | | | <i>D</i> ¹⁾ mm | <i>b</i> ^{+0.2} ₀ | G kgs. | SD |
| 21 | G 21x29x4 | SD 21x29x4 | 29 ^{+0.119} _{+0.085} | 4 | 2.2 | 2.1 |
| 22 | G 22x28x4 | SD 22x28x4 | 28 ^{+0.119} _{+0.085} | 4 | 1.8 | 1.9 |
| 22 | G 22x30x4 | SD 22x30x4 | 30 ^{+0.119} _{+0.085} | 4 | 2.2 | 2.3 |
| 24 | G 24x32x4 | SD 24x32x4 | 32 ^{+0.143} _{+0.043} | 4 | 2.5 | 2.4 |
| 25 | G 25x32x4 | SD 25x32x4 | 32 ^{+0.143} _{+0.043} | 4 | 2.3 | 2.2 |
| 25 | G 25x33x4 | SD 25x33x4 | 33 ^{+0.143} _{+0.043} | 4 | 2.5 | 2.5 |
| 25 | G 25x35x4 | SD 25x35x4 | 35 ^{+0.143} _{+0.043} | 4 | 2.6 | 2.6 |
| 26 | G 26x34x4 | SD 26x34x4 | 34 ^{+0.143} _{+0.043} | 4 | 2.6 | 2.6 |
| 28 | G 28x35x4 | SD 28x35x4 | 35 ^{+0.143} _{+0.043} | 4 | 2.4 | 2.5 |
| 28 | G 28x37x4 | SD 28x37x4 | 37 ^{+0.143} _{+0.043} | 4 | 3.1 | 2.8 |
| 29 | G 29x37x4 | SD 29x37x4 | 37 ^{+0.143} _{+0.043} | 4 | 2.7 | 2.7 |
| 29 | G 29x38x4 | SD 29x38x4 | 38 ^{+0.143} _{+0.043} | 4 | 3.2 | 2.9 |
| 30 | G 30x37x4 | SD 30x37x4 | 37 ^{+0.143} _{+0.043} | 4 | 2.7 | 2.6 |
| 30 | G 30x40x4 | SD 30x40x4 | 40 ^{+0.143} _{+0.043} | 4 | 3.6 | 3.3 |
| 32 | G 32x42x4 | SD 32x42x4 | 42 ^{+0.143} _{+0.043} | 4 | 3.7 | 3.9 |
| 32 | G 32x45x4 | SD 32x45x4 | 45 ^{+0.143} _{+0.043} | 4 | 5.1 | 5.2 |
| 35 | G 35x42x4 | SD 35x42x4 | 42 ^{+0.143} _{+0.043} | 4 | 3.0 | 2.9 |
| 35 | G 35x45x4 | SD 35x45x4 | 45 ^{+0.143} _{+0.043} | 4 | 4.1 | 3.6 |
| 37 | G 37x47x4 | SD 37x47x4 | 47 ^{+0.143} _{+0.043} | 4 | 4.0 | 3.8 |
| 38 | G 38x48x4 | SD 38x48x4 | 48 ^{+0.143} _{+0.043} | 4 | 4.4 | 4.0 |
| 40 | G 40x47x4 | SD 40x47x4 | 47 ^{+0.143} _{+0.043} | 4 | 3.3 | 3.5 |
| 40 | G 40x50x4 | SD 40x50x4 | 50 ^{+0.143} _{+0.043} | 4 | 4.6 | 4.0 |
| 40 | G 40x52x4 | SD 40x52x4 | 52 ^{+0.173} _{+0.053} | 4 | 4.8 | 4.7 |
| 42 | G 42x52x4 | SD 42x52x4 | 52 ^{+0.173} _{+0.053} | 4 | 4.7 | 4.2 |
| 43 | G 43x53x4 | SD 43x53x4 | 53 ^{+0.173} _{+0.053} | 4 | 4.8 | 4.3 |
| 45 | G 45x52x4 | SD 45x52x4 | 52 ^{+0.173} _{+0.053} | 4 | 3.8 | 3.8 |
| 45 | G 45x55x4 | SD 45x55x4 | 55 ^{+0.173} _{+0.053} | 4 | 5.2 | 5.5 |
| 50 | G 50x58x4 | SD 50x58x4 | 58 ^{+0.173} _{+0.053} | 4 | 4.5 | 5.2 |
| 50 | G 50x62x4 | SD 50x62x4 | 62 ^{+0.173} _{+0.053} | 4 | 10.4 | 10.0 |

Notes: 1) The tolerance of the outside diameter is an average of two measurements taken at equally spaced points on the outside surface.



Non-standard

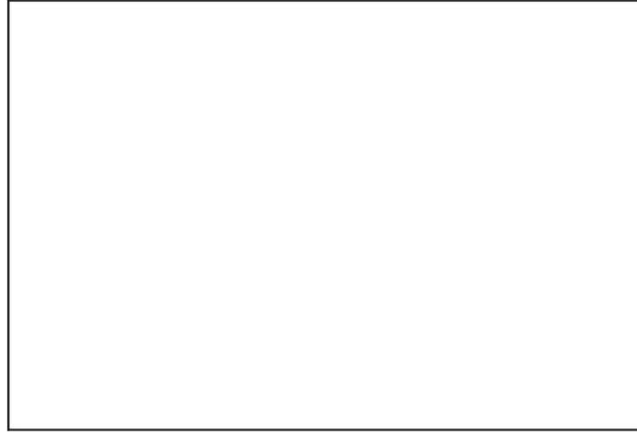

PRODUCT INFORMATION

P162 - 169



PWTR

P162 - 163



PWKR

P164 - 165

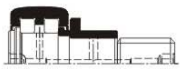

PWKRE

P166 - 167



NUKRE

P168 - 169

Needle roller bearings with thrust cylindrical roller bearings series PWTR .. 2RS

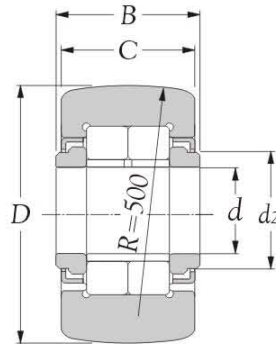

| Inner bore D 0/+0.05 mm | Bearing number | Boundary dimensions | | | | | | Basic load ratings | | | |
|------------------------------------|----------------|---------------------|-----|-----|-------|-----|-------|---------------------|-----------------|---------------------|-----------------|
| | | d | B | C | d_2 | r | r_1 | dynamic C N | static C_0 | dynamic C N | static C_0 |
| 35 | PWTR 15 2RS | 15 | 19 | 18 | 20.0 | 0.6 | 0.3 | 12600 | 14600 | 10700 | 14600 |
| 40 | PWTR 17 2RS | 17 | 21 | 20 | 22.0 | 1.0 | 0.5 | 14300 | 17900 | 16500 | 17900 |
| 42 | PWTR 1542 2RS | 15 | 19 | 18 | 20.0 | 0.6 | 0.3 | 14700 | 16200 | 16200 | 16200 |
| 47 | PWTR 1747 2RS | 17 | 21 | 20 | 22.0 | 1.0 | 0.5 | 15900 | 18400 | 18400 | 18400 |
| 47 | PWTR 20 2RS | 20 | 25 | 24 | 27.0 | 1.0 | 0.5 | 24500 | 30500 | 20700 | 30500 |
| 52 | PWTR 2052 2RS | 20 | 25 | 24 | 27.0 | 1.0 | 0.5 | 27000 | 35000 | 31000 | 35000 |
| 52 | PWTR 25 2RS | 25 | 25 | 24 | 31.0 | 1.0 | 0.5 | 25000 | 33000 | 21800 | 33000 |
| 62 | PWTR 2562 2RS | 25 | 25 | 24 | 31.0 | 1.0 | 0.5 | 30000 | 42500 | 42500 | 42500 |
| 62 | PWTR 30 2RS | 30 | 29 | 28 | 38.0 | 1.0 | 0.5 | 35000 | 45500 | 29000 | 45500 |
| 72 | PWTR 3072 2RS | 30 | 29 | 28 | 38.0 | 1.0 | 0.5 | 41000 | 56000 | 54000 | 56000 |
| 72 | PWTR 35 2RS | 35 | 29 | 28 | 44.0 | 1.1 | 0.6 | 38500 | 54000 | 39000 | 54000 |
| 80 | PWTR 3580 2RS | 35 | 29 | 28 | 44.0 | 1.1 | 0.6 | 43500 | 63000 | 59000 | 63000 |
| 80 | PWTR 40 2RS | 40 | 32 | 30 | 50.5 | 1.1 | 0.6 | 45000 | 61000 | 39500 | 61000 |
| 85 | PWTR 45 2RS | 45 | 32 | 30 | 55.2 | 1.1 | 0.6 | 45500 | 63000 | 41000 | 63000 |
| 90 | PWTR 4090 2RS | 40 | 32 | 30 | 50.5 | 1.1 | 0.6 | 52000 | 75000 | 67000 | 75000 |
| 90 | PWTR 50 2RS | 50 | 32 | 30 | 59.8 | 1.1 | 0.6 | 46000 | 66000 | 42000 | 66000 |
| 100 | PWTR 45100 2RS | 45 | 32 | 30 | 55.2 | 1.1 | 0.6 | 56000 | 85000 | 85000 | 85000 |
| 110 | PWTR 50110 2RS | 50 | 32 | 30 | 59.8 | 1.1 | 0.6 | 59000 | 94000 | 94000 | 94000 |

Notes: 1) These values are the allowable minimum dimensions of the chamfer dimension r .

Needle roller bearings with thrust cylindrical roller bearings series PWTR .. 2RS

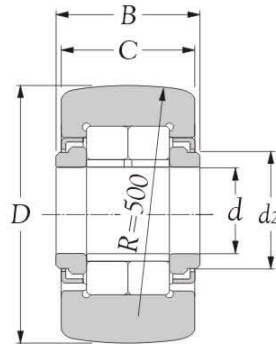

| Fatigue limit load N | Max runout speed grease r/min | Weight kg(s). |
|-------------------------|----------------------------------|------------------|
| 1760 | 6000 | 0.099 |
| 2160 | 5000 | 0.147 |
| 2140 | 6000 | 0.158 |
| 2440 | 5000 | 0.220 |
| 3750 | 3800 | 0.245 |
| 4250 | 3800 | 0.321 |
| 4100 | 3800 | 0.281 |
| 5200 | 3800 | 0.450 |
| 5800 | 2200 | 0.465 |
| 7200 | 2200 | 0.697 |
| 6900 | 1800 | 0.630 |
| 8100 | 1800 | 0.836 |
| 7900 | 1500 | 0.816 |
| 8200 | 1300 | 0.883 |
| 9600 | 1500 | 1.129 |
| 8500 | 1100 | 0.950 |
| 10900 | 1300 | 1.396 |
| 12100 | 1100 | 1.690 |



Cam followers stud type truck rollers series PWKR .. 2RS

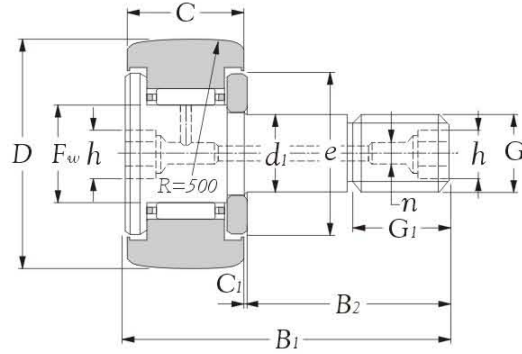

| Inner bore D 0/+0.05 mm | Bearing number | Boundary dimensions | | | | | | Basic load ratings | | | |
|------------------------------------|----------------|---------------------|-----|-----|-------|-----|-------|--------------------|-----------------|----------------|-----------------|
| | | d | B | C | d_1 | r | r_1 | dynamic C | static C_0 | dynamic C | static C_0 |
| 35 | PWKR 35 2RS | 16 | 52 | 18 | 20 | 0.8 | 0.6 | 12600 | 14600 | 10700 | 14600 |
| 40 | PWKR 40 2RS | 18 | 58 | 20 | 22 | 0.8 | 1.0 | 14300 | 17900 | 16500 | 17900 |
| 47 | PWKR 47 2RS | 20 | 66 | 24 | 27 | 0.8 | 1.0 | 24500 | 30500 | 20700 | 30500 |
| 52 | PWKR 52 2RS | 20 | 66 | 24 | 31 | 0.8 | 1.0 | 25000 | 33000 | 21800 | 33000 |
| 62 | PWKR 62 2RS | 24 | 80 | 28 | 38 | 1.3 | 1.0 | 35000 | 45500 | 29000 | 45500 |
| 72 | PWKR 72 2RS | 24 | 80 | 28 | 44 | 1.3 | 1.1 | 38500 | 54000 | 39000 | 54000 |
| 80 | PWKR 80 2RS | 30 | 100 | 35 | 47 | 1.0 | 1.1 | 56000 | 79000 | 60000 | 79000 |
| 90 | PWKR 90 2RS | 30 | 100 | 35 | 47 | 1.0 | 1.1 | 62000 | 92000 | 92000 | 92000 |

Notes: 1) These values are the allowable minimum dimensions of the chamfer dimension r .

Cam followers stud type truck rollers series PWKR .. 2RS

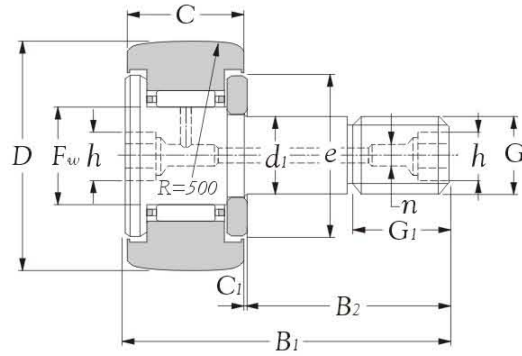

| Fatigue limit load | Max runout speed grease | Weight |
|--------------------|-------------------------|--------|
| N | r/min | kg(s). |
| 1760 | 6000 | - |
| 2160 | 5000 | - |
| 3750 | 3800 | 0.400 |
| 4100 | 3800 | 0.470 |
| 5800 | 2200 | 0.824 |
| 6900 | 2200 | 1.050 |
| 10600 | 1800 | 1.670 |
| 12200 | 1800 | 2.020 |

Cam followers stud type truck rollers series PWKRE .. 2RS

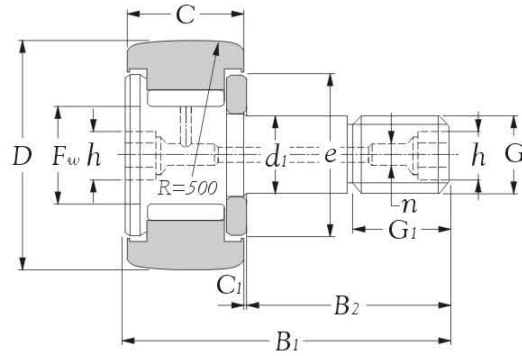

| Inner bore D 0/+0.05 mm | Bearing number | Boundary dimensions | | | | | | Basic load ratings | | | |
|------------------------------------|----------------|---------------------|-----|-----|-------|-----|-------|--------------------|-----------------|----------------|-----------------|
| | | d | B | C | d_1 | r | r_1 | dynamic C | static C_0 | dynamic C | static C_0 |
| | | mm | | | | | | | | | |
| 35 | PWKRE 35 2RS | 16 | 52 | 18 | 27.6 | 3.8 | 0.6 | 12600 | 14600 | 10700 | 14600 |
| 40 | PWKRE 40 2RS | 18 | 58 | 20 | 30.0 | 3.8 | 1.0 | 14300 | 17900 | 16500 | 17900 |
| 47 | PWKRE 47 2RS | 20 | 66 | 24 | 27.0 | 0.8 | 1.0 | 24500 | 30500 | 20700 | 30500 |
| 52 | PWKRE 52 2RS | 20 | 66 | 24 | 31.0 | 0.8 | 1.0 | 25000 | 33000 | 21800 | 33000 |
| 62 | PWKRE 62 2RS | 24 | 80 | 28 | 38.0 | 1.3 | 1.0 | 35000 | 45500 | 29000 | 45500 |
| 72 | PWKRE 72 2RS | 24 | 80 | 28 | 44.0 | 1.3 | 1.1 | 38500 | 54000 | 39000 | 54000 |
| 80 | PWKRE 80 2RS | 30 | 100 | 35 | 47.0 | 1.0 | 1.1 | 56000 | 79000 | 60000 | 79000 |
| 90 | PWKRE 90 2RS | 30 | 100 | 35 | 47.0 | 1.0 | 1.1 | 62000 | 92000 | 92000 | 92000 |

Notes: 1) These values are the allowable minimum dimensions of the chamfer dimension r .

Cam followers stud type truck rollers
series PWKRE .. 2RS

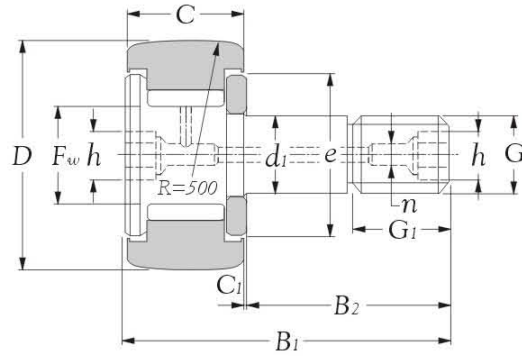

| Fatigue limit load | Max runout speed grease | Weight |
|--------------------|-------------------------|--------|
| N | r/min | kg(s). |
| 1760 | 6000 | - |
| 2160 | 5000 | - |
| 3750 | 3800 | 0.400 |
| 4100 | 3800 | 0.470 |
| 5800 | 2200 | 0.824 |
| 6900 | 2200 | 1.050 |
| 10600 | 1800 | 1.670 |
| 12200 | 1800 | 2.020 |



Cam followers stud type truck rollers (multi-row cylindrical roller bearings) series NUKRE

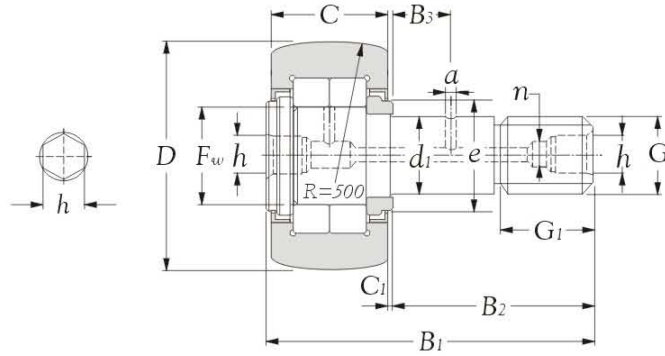

| Inner bore D 0/+0.05 mm | Bearing number | Boundary dimensions | | | | | | Basic load ratings | | | |
|------------------------------------|----------------|---------------------|-----|-----|-------|-----|-------|--------------------|-----------------|----------------|-----------------|
| | | d | B | C | d_2 | r | r_1 | dynamic C | static C_0 | dynamic C | static C_0 |
| | | mm | | | | | | | | | |
| 35 | NUKRE 35 | 16 | 52 | 18 | 27.6 | 3.8 | 0.6 | 15300 | 18700 | 8500 | 16800 |
| 40 | NUKRE 40 | 18 | 58 | 20 | 30.0 | 3.8 | 1.0 | 18700 | 24900 | 13000 | 24900 |
| 47 | NUKRE 47 | 20 | 66 | 24 | 27.0 | 0.8 | 1.0 | 28500 | 37500 | 16200 | 32500 |
| 52 | NUKRE 52 | 20 | 66 | 24 | 31.0 | 0.8 | 1.0 | 29000 | 40500 | 17100 | 34000 |
| 62 | NUKRE 62 | 24 | 80 | 28 | 38.0 | 1.3 | 1.0 | 40000 | 55000 | 23400 | 46000 |
| 72 | NUKRE 72 | 24 | 80 | 28 | 44.0 | 1.3 | 1.1 | 45000 | 65000 | 31500 | 63000 |
| 80 | NUKRE 80 | 30 | 100 | 35 | 47.0 | 1.0 | 1.1 | 69000 | 104000 | 47500 | 95000 |
| 90 | NUKRE 90 | 30 | 100 | 35 | 47.0 | 1.0 | 1.1 | 78000 | 123000 | 76000 | 123000 |

Notes: 1) These values are the allowable minimum dimensions of the chamfer dimension r .

**Cam followers stud type truck rollers (multi-row cylindrical roller bearings)
series NUKRE**

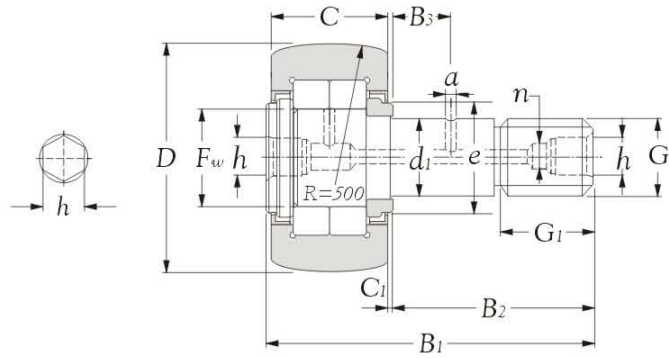

| Fatigue limit load | Max runout speed grease | Weight |
|--------------------|-------------------------|--------|
| N | r/min | kg(s). |
| 2430 | 6500 | 0.177 |
| 3150 | 5500 | 0.258 |
| 4850 | 4200 | 0.400 |
| 5300 | 4200 | 0.470 |
| 7300 | 2600 | 0.824 |
| 8700 | 2600 | 1.050 |
| 14100 | 1800 | 1.670 |
| 16700 | 1800 | 2.020 |



KSM[®]



Track Roller Bearings





TECHNICAL INFORMATION

T173 - 181

| | |
|--------------------------------------|------------|
| 1. Bearing materials | T173 |
| 2. Shields and seals | T173 - 174 |
| 3. Bearing tolerances | T174 - 176 |
| 4. Bearing fits | T177 - 178 |
| 5. Bearing internal clearance | T178 |
| 6. Lubrication | T179 |
| 7. Load rating and life | T179 - 180 |
| 8. Bearing handling | T180 |
| 9. Allowable speed | T181 |

1. Bearing materials

The internal design of **KSM** track rollers is the same as in single row or Double-row Angular Contact Ball Bearings. The units can carry axial loads in both directions and, due to the thickness of the outer ring, large radial loads. The standard product are produced from high quality bearing steel, with a hardness of 58 to 62 HRC. Some types are also available in stainless steel (440C) with hardness >58 HRC.

The track rollers contained in this catalogue are produced with standard tolerances (ISO 492) and standard clearance (Normal). The track rollers are produced in two distinct families. Cylindrical or crowned outer ring and profiled outer ring.

These track rollers are available in single and double row design. They are available with straight cylindrical OD or crowned profile OD. The crowned OD is used to reduce the edge stresses caused by possible misalignment errors. The cylindrical OD can provide increased support due to the longer contact profile.

These products are used typically on flat surfaces. Some of the most common applications are:

- Transfer rolls
- idler rollers
- Support rollers
- Straightening rolls

2. Shields and seals

2.1 Types

2.1.1 Track rollers LR 2, LR 2..RRU

These single row ball track rollers are available in following different versions.

- LR 2..X-2RS: cylindrical OD, with light contact seals.
- LR 2..X-2RSR: crowned cylindrical OD, with contact seals.
- LR 2..2RS: crowned OD, with light contact seals.
- LR 2..2RSR: crowned OD, with contact seals.
- LR 2..RRU: crowned OD with contact seals protected by a metal shield, inner ring with increased width to allow additional lubricant storage.

2.1.2 Track rollers LR 52, LR 53

These are double row angular contact ball track rollers. Due to their internal design, they can carry axial loads of large magnitude. They are available in three versions:

- LR 52..2RS, LR 53..2RS: crowned OD, with light contact seals.
- LR 52..X-2Z, LR 53..X-2Z: cylindrical OD, with metal shields.
- LR 52..2Z, LR 53..2Z: crowned OD, with metal shields.

The track rollers with profiled outer ring are basically Double-row Angular Contact Ball Bearings with a reinforced and profiled outer ring. The outer ring profile allows the units to operate on round shafts or other types of profiled raceways. The outer profile can have three different designs;

- Track rollers with gothic arch groove - type LFR



2.2 Types - Track rollers LFR

The track rollers series LFR can be used on round shafts with diameter from 4 mm to 50 mm. The contact between track roller gothic arch groove profile and shaft is on two points.

This allows the units to carry loads in both axial and radial direction.

The track rollers are available with either shields 2Z or contact seals 2RS.

They are available with either non-contacting seals 2RS or contact seals 2RSR.

3. Bearing tolerances

3.1 Standard of tolerances

Track roller bearing "tolerances" or dimensional accuracy and running accuracy, are regulated by ISO standard (rolling bearing tolerances). For dimensional accuracy, these standards prescribe the tolerances necessary when installing bearings on shafts or in housings.

Running accuracy is defined as the allowable limits for bearing runout during operation.

Table 3.1 Comparison of tolerance classifications of national standards

| Standard | | Tolerance class | | | | |
|--|-----|--------------------------|---------|---------|---------|---------|
| International Organization for Standardization (ISO) | ISO | P0 | P6 | P5 | P4 | P2 |
| Deutsches Institut für Normung (DIN) | DIN | Normal class Class 6X | Class 6 | Class 5 | Class 4 | Class 2 |
| American National Standards Institute (ANSI) | JIS | ABEC-1 | ABEC-3 | ABEC-5 | ABEC-7 | ABEC-9 |



3.2 Tolerances for radial bearings

Table 3.2 Inner rings

(Unit : μm)

| Nominal bore diameter d | | Single plane mean bore diameter deviation Δd_{mp} | | | | | | | | | | Single radial plane bore diameter variation V_{dp} | | | | | | | | | |
|---------------------------|-------|---|-----|---------|-----|---------|-----|----------------------|-----|----------------------|------|--|-----|---------|-----|---------|-----|---------|-----|---------|-----|
| mm | | | | | | | | | | | | diameter series 9 | | | | | | | | | |
| | | class 0 | | class 6 | | class 5 | | class 4 ^① | | class 2 ^① | | class 0 | | class 6 | | class 5 | | class 4 | | class 2 | |
| over | incl. | high | low | high | low | high | low | high | low | high | low | high | low | high | low | high | low | high | low | high | low |
| 10 | 18 | 0 | -8 | 0 | -7 | 0 | -5 | 0 | -4 | 0 | -2.5 | 10 | 9 | 5 | 4 | 2.5 | 8 | 7 | 4 | 3 | 2.5 |
| 18 | 30 | 0 | -10 | 0 | -8 | 0 | -6 | 0 | -5 | 0 | -2.5 | 13 | 10 | 6 | 5 | 2.5 | 10 | 8 | 5 | 4 | 2.5 |
| 30 | 50 | 0 | -12 | 0 | -10 | 0 | -8 | 0 | -6 | 0 | -2.5 | 15 | 13 | 8 | 6 | 2.5 | 12 | 10 | 6 | 5 | 2.5 |

Table 3.3 Inner rings

(Unit : μm)

| Nominal bore diameter d | | Single radial plane bore diameter variation V_{dp} | | | | | Mean single plane bore diameter variation V_{dmp} | | | | | Inner ring radial runout K_{ia} | | | | | Face runout with bore S_d | | |
|---------------------------|-------|--|---------|---------|---------|---------|---|---------|---------|---------|---------|-----------------------------------|---------|---------|---------|---------|-----------------------------|---------|---------|
| mm | | max.diameter series 2,3,4 | | | | | | | | | | | | | | | | | |
| | | class 0 | class 6 | class 5 | class 4 | class 2 | class 0 | class 6 | class 5 | class 4 | class 2 | class 0 | class 6 | class 5 | class 4 | class 2 | class 5 | class 4 | class 2 |
| over | incl. | max. | | | | | max. | | | | | max. | | | | | max. | | |
| 10 | 18 | 6 | 5 | 4 | 3 | 2.5 | 6 | 5 | 3 | 2.0 | 1.5 | 10 | 7 | 4 | 2.5 | 1.5 | 7.0 | 3.0 | 1.5 |
| 18 | 30 | 8 | 6 | 5 | 4 | 2.5 | 8 | 6 | 3 | 2.5 | 1.5 | 13 | 8 | 4 | 3.0 | 2.5 | 8.0 | 4.0 | 1.5 |
| 30 | 50 | 9 | 8 | 6 | 5 | 2.5 | 9 | 8 | 4 | 3.0 | 1.5 | 15 | 10 | 5 | 4.0 | 2.5 | 8.0 | 4.0 | 1.5 |

Table 3.4 Inner rings

(Unit : μm)

| Nominal bore diameter d | | Inner ring axial runout (with side) S_{ia} ^② | | | Inner ring width deviation ΔB_s | | | | | | | | Inner ring width variation V_{Bs} | | | | | | |
|---------------------------|-------|---|---------|---------|---|------|-----------|------|-----------------------|------|-----------|------|-------------------------------------|------|---------|---------|---------|---------|---------|
| mm | | | | | normal | | | | modified ^③ | | | | | | | | | | |
| | | class 5 | class 4 | class 2 | class 0,6 | | class 5,4 | | class 2 | | class 0,6 | | class 5,4 | | class 0 | class 6 | class 5 | class 4 | class 2 |
| over | incl. | | | | high | low | high | low | high | low | high | low | high | low | max. | | | | |
| 10 | 18 | 7 | 3 | 1.5 | 0 | -120 | 0 | -80 | 0 | -80 | 0 | -250 | 0 | -250 | 20 | 20 | 5 | 2.5 | 1.5 |
| 18 | 30 | 8 | 4 | 2.5 | 0 | -120 | 0 | -120 | 0 | -120 | 0 | -250 | 0 | -250 | 20 | 20 | 5 | 2.5 | 1.5 |
| 30 | 50 | 8 | 4 | 2.5 | 0 | -120 | 0 | -120 | 0 | -120 | 0 | -380 | 0 | -250 | 20 | 20 | 5 | 3.0 | 1.5 |

Note: ^① The dimensional difference Δd_s of bore diameter to applied for class 4 and 2 is the same as the tolerance of dimensional difference Δd_{mp} of average bore diameter. However, the dimensional difference is applied to diameter series 0, 1, 2, 3 and 4 against Class 4, and to all the diameter series against Class 2.

^② To be applied for deep groove ball bearing and angular contact ball bearings.

^③ To be applied for individual raceway rings manufactured for combined bearing use.

Symbols: Δd_{mp} : deviation of the mean bore diameter from the nominal ($\Delta d_{mp} = \bar{d}_{mp} - d$).

V_{dp} : bore diameter variation; difference between the largest and smallest single bore diameters in one plane.

V_{dmp} : mean bore diameter variation; difference between the largest and smallest mean bore diameters of one ring or washer.

K_{ia} : radial runout of assembled bearing inner ring and assembled bearing outer ring, respectively.

S_d : side face runout with reference to bore (of inner ring).

S_{ia} : side face runout of assembled bearing inner ring and assembled bearing outer ring, respectively.

ΔB_s : deviation of single inner ring width or single outer ring width from the nominal ($\Delta B_s = B_s - B$ etc.)

V_{Bs} : ring width variation; difference between the largest and smallest single widths of inner ring and of outer ring, respectively.



Table 3.5 Outer rings

(Unit : μm)

| Nominal Outside diameter <i>D</i> mm | | Single plane mean outside diameter deviation ΔD_{mp} | | | | | | | | | | Single radial plane outside diameter variation V_{Dp} | | | | | | | | | |
|--|-------|---|-----|---------|-----|---------|-----|----------------------|-----|----------------------|------|--|---------|---------|---------|---------|-------------------------|---------|---------|---------|---------|
| over | incl. | class 0 | | class 6 | | class 5 | | class 4 ⁵ | | class 2 ⁶ | | diameter series 9 | | | | | max diameter series 0.1 | | | | |
| | | high | low | high | low | high | low | high | low | high | low | class 0 | class 6 | class 5 | class 4 | class 2 | class 0 | class 6 | class 5 | class 4 | class 2 |
| 6 | 18 | 0 | -8 | 0 | -7 | 0 | -5 | 0 | -4 | 0 | -2.5 | 10 | 9 | 5 | 4 | 2.5 | 8 | 7 | 4 | 3 | 2.5 |
| 18 | 30 | 0 | -9 | 0 | -8 | 0 | -6 | 0 | -5 | 0 | -4.0 | 12 | 10 | 6 | 5 | 4.0 | 9 | 8 | 5 | 4 | 4.0 |
| 30 | 50 | 0 | -11 | 0 | -9 | 0 | -7 | 0 | -6 | 0 | -4.0 | 14 | 11 | 7 | 6 | 4.0 | 11 | 9 | 5 | 5 | 4.0 |
| 50 | 80 | 0 | -13 | 0 | -11 | 0 | -9 | 0 | -7 | 0 | -4.0 | 16 | 14 | 9 | 7 | 4.0 | 13 | 11 | 7 | 5 | 4.0 |
| 80 | 120 | 0 | -15 | 0 | -13 | 0 | -10 | 0 | -8 | 0 | -5.0 | 19 | 16 | 10 | 8 | 5.0 | 19 | 16 | 8 | 6 | 5.0 |

Table 3.6 Outer rings

(Unit : μm)

| Nominal Outside diameter <i>D</i> mm | | Single radial plane outside diameter variation V_{Dp} | | | | | Single radial plane outside diameter variation V_{Dp}^{c} | | Mean single plane outside diameter variation V_{Dmp} | | | | |
|--|-------|--|---------|---------|---------|---------|---|-------------------|---|---------|---------|---------|---------|
| over | incl. | max diameter series 2,3,4 | | | | | capped bearings diameter series 2,3,4 | | max. | | | | |
| | | class 0 | class 6 | class 5 | class 4 | class 2 | class 0 | 0,1,2,3,4 class 6 | class 0 | class 6 | class 5 | class 4 | class 2 |
| 6 | 18 | 6 | 5 | 4 | 3 | 2.5 | 10 | 9 | 6 | 5 | 3 | 2.0 | 1.5 |
| 18 | 30 | 7 | 6 | 5 | 4 | 4.0 | 12 | 10 | 7 | 6 | 3 | 2.5 | 2.0 |
| 30 | 50 | 8 | 7 | 5 | 5 | 4.0 | 16 | 13 | 8 | 7 | 4 | 3.0 | 2.0 |
| 50 | 80 | 10 | 8 | 7 | 5 | 4.0 | 20 | 16 | 10 | 8 | 5 | 3.5 | 2.0 |
| 80 | 120 | 11 | 10 | 8 | 6 | 5.0 | 26 | 20 | 11 | 10 | 5 | 4.0 | 2.5 |

Symbols: ΔD_{mp} : deviation of the mean outside diameter from the nominal ($\Delta D_{mp} = D_{mp} - D$).

V_{Dp} : outside diameter variation; difference between the largest and smallest single outside diameters in one plane.

V_{dmp} : mean outside diameter variation; difference between the largest and smallest mean outside diameters of one ring or washer.

Table 3.7 Outer rings

(Unit : μm)

| Nominal Outside diameter <i>D</i> mm | | Outer ring radial runout K_{ea} | | | | | Outside surface inclination S_D | | | Outside ring axial runout S_{ea} ⁷ | | | Outer ring width deviation ΔC_s | Outer ring width variation V_{cs} | | | |
|--|-------|--------------------------------------|---------|---------|---------|---------|--------------------------------------|---------|---------|--|---------|---------|--|--|---------|---------|---------|
| over | incl. | max. | | | | | max. | | | max. | | | all type | max. | | | |
| | | class 0 | class 6 | class 5 | class 4 | class 2 | class 5 | class 4 | class 2 | class 5 | class 4 | class 2 | | class 0,6 | class 5 | class 4 | class 2 |
| 6 | 18 | 15 | 8 | 5 | 3 | 1.5 | 8 | 4 | 1.5 | 8 | 5 | 1.5 | Identical to | Identical to | 5 | 2.5 | 1.5 |
| 18 | 30 | 15 | 9 | 6 | 4 | 2.5 | 8 | 4 | 1.5 | 8 | 5 | 2.5 | ΔB_s of inner | ΔB_s and V_{bs} | 5 | 2.5 | 1.5 |
| 30 | 50 | 20 | 10 | 7 | 5 | 2.5 | 8 | 4 | 1.5 | 8 | 5 | 2.5 | ring of same | of inner | 5 | 2.5 | 1.5 |
| 50 | 80 | 25 | 13 | 8 | 5 | 4.0 | 8 | 4 | 1.5 | 10 | 5 | 4.0 | bearing | ring of same | 6 | 3.0 | 1.5 |
| 80 | 120 | 35 | 18 | 10 | 6 | 5.0 | 9 | 5 | 2.5 | 11 | 6 | 5.0 | | bearing | 8 | 4.0 | 2.5 |

Note: ⁵ The dimensional difference ΔD_s of outer diameter to be applied for classes 4 and 2 is the same as the tolerance of dimensional difference ΔD_{mp} of average outer diameter. However, the dimensional difference is applied to diameter series 0,1,2,3 and 4 against Class 4, and also to all the diameter series against class 2.

⁶ To be applied in case snap rings are not installed on the bearings.

⁷ To be applied for Track Roller Bearings.

Symbols: K_{ea} : radial runout of assembled bearing inner ring and assembled bearing outer ring, respectively.

S_D : outside inclination variation: variation in inclination of outside cylindrical surface to outer ring side face.

S_{ea} : side face runout of assembled bearing inner ring and assembled bearing outer ring, respectively.

ΔC_s : deviation of single inner ring width or single outer ring width from the nominal ($\Delta B_s = B_s - B$ etc.)

V_{cs} : ring width variation; difference between the largest and smallest single widths of inner ring and of outer ring, respectively.



4. Bearing fits

Track rollers are precision machine elements. These products must be very carefully handled before and during fitting. Their trouble-free operation depends largely on the care taken during fitting

4.1 Compatibility and miscibility

The anti-corrosive preservation oil used for rolling bearings is compatible and miscible with oils and greases with a mineral oil base. Compatibility should be checked if the following are used:

- synthetic lubricants
- thickeners other than lithium or lithium complex soaps.

If there is an incompatibility, the anti-corrosive oil should be washed out before greasing, particularly in the following cases:

- lubricants based on PTFE/alkoxyfluoroether
- lubricants with a polycarbamide thickener

and if

- the lubricant is changed
- the rolling bearings are contaminated.

If in doubt, please contact the relevant lubricant manufacturer.

4.2 Guidelines for fitting

- The assembly area must be kept clean and free from dust
- Protect bearings from dust, contaminants and moisture
 - contaminants have a detrimental influence on the running and operating life of rolling bearings
- Inspect the housing bore and shaft/axis seating for
 - dimensional and geometrical tolerances
 - cleanliness
- Lightly oil the bearing ring seating surfaces or rub with solid lubricant
- Do not cool the bearings excessively
 - Moisture due to condensation can lead to corrosion in the bearings and bearing seatings
- After fitting
 - charge ungreased rolling bearings with lubricant
 - check the correct functioning of the bearing arrangement.

4.3 Fitting tools

- Induction heating device (see figure below)
- Heating cupboard
 - heating up to +30 °C

Mechanical or hydraulic press

- fitting sleeves should be used which cover the whole circumference of the bearing ring end faces
- Hammer and fitting sleeve
 - light hammer blows should be centrally directed on the fitting sleeve

Note: Fitting forces must never be directed through the rolling elements. Direct blows on the bearing rings must be avoided.



Heating with an induction heater

4.4 Dismantling guidelines

- Dismantling should be taken into consideration in the original design of the bearing location
- If the bearings are to be reused:
 - direct blows on the bearing rings should be avoided
 - dismantling forces should not be applied through the rolling elements
 - bearings should be carefully cleaned once dismantled
 - do not use a concentrated or hard flame.

4.5 Fitting and dismantling of yoke type track rollers (ball type)

- If the tolerance zone is unfavourable: the bearing should be pressed into place using a fitting press (see figure below)
- The inner ring must be fitted such that the pressing-in force is distributed uniformly on the end face of the inner ring.

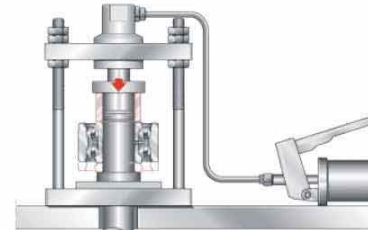

Fitting of the yoke type track roller using a fitting press

- Note: Fitting forces must not be directed through the rolling elements.
It must be ensured that the seals are not damaged during fitting.
- Track rollers must be secured axially according to the advice given.

Note: Extraction forces must not be directed through the outer ring. This could damage the rolling elements and seals.

4.6 Fitting and dismantling of stud type track rollers (ball type)

Stud type track rollers are fitted and dismantled by methods similar to those used for yoke type track rollers (see figure below).

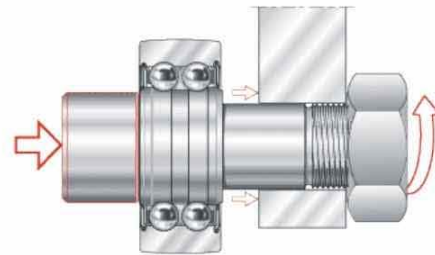

Fitting of a stud type track roller

- Note: The tightening torques given in the dimension table must be observed. Only then can the permissible radial load be ensured.
Screws and nuts of grade ≥ 8.8 must be used.

5. Bearing internal clearance

TrackRoller Bearing internal clearance (initial clearance) is the amount of internal clearance a bearing has before being installed on a shaft or in a housing. The internal clearance values for KSM Track roller bearing classes are shown in tables 5.1

Table 5.1 Radial internal clearance of track roller bearings

(Unit : μm)

| Nominal bore diameter d (mm) | | C2 | | Normal | | C3 | | C4 | |
|---------------------------------|-------|------|------|--------|------|------|------|------|------|
| over | Incl. | min. | max. | min. | max. | min. | max. | min. | max. |
| - | 10 | 6 | 12 | 8 | 15 | 15 | 22 | 22 | 30 |
| 10 | 18 | 6 | 12 | 8 | 15 | 15 | 24 | 30 | 40 |
| 18 | 30 | 6 | 12 | 10 | 20 | 20 | 32 | 40 | 55 |
| 30 | 50 | 8 | 14 | 14 | 25 | 25 | 40 | 55 | 75 |



6. Lubrication

6.1 Track rollers series LR 2..are supplied grease filled. (The lithium soap grease).

6.2 Track rollers series LR 52..are supplied grease filled. (The lithium soap grease).

6.3 Track rollers LFR

The units are supplied with lifetime grease lubrication

The size with an outside diameter 52 mm or greater have a lubrication hole in the inner ring. To prevent mixing of greases with different characteristics, please insure to perform the lubrication of the units with lubricants that have the same characteristics as the grease used at the factory. Mounting bolts are available in both eccentric

7. Load rating and life

If the track rollers operate on a flat surface/raceway, the outer ring deforms (fig.1)

When compared with a bearing mounted in a suitable housing, track rollers have the following characteristics:

- Modified load distribution

This is accounted for by using the load factors C_w and C_{ow} when calculating the life.

- Alternating bending stress on the outer ring

This is taken into account by the load coefficients F_r perm and F_{ro} perm (see dimension tables). The stresses must not exceed the allowable limits.

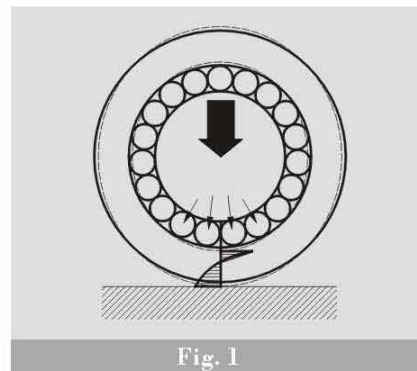

7.1 Load ratings and life calculation

The dynamic load rating of the track roller is determined by the fatigue limit of the material. The life of the track roller is defined as the period of use before the pearance of fatigue. The ability of a track roller to carry dynamic loads is statistically derived.

7.1.1 Life calculation

The formula to calculate the nominal life is as follows:

$$L = \left(\frac{C_w}{P}\right)^3$$

$$L_h = \frac{833}{H \cdot n_{osz}} \left(\frac{C_w}{P}\right)^3$$

$$L_h = \frac{1666}{V_m} \left(\frac{C_w}{P}\right)^3$$

L = nominal life in 10^5 m reached by 90% of a statistically significant number of apparently identical bearing operating under the same loading condition before the onset of metal fatigue.

L_h [h] = nominal life in hours

C_{4v} [N] = dynamic load rating. Is the load that would yield a nominal life of 105 m.

P [N] = equivalent dynamic load

H [m] = stroke

n_{osz} [min⁻¹] = frequency of operation

V_m [m/min] = mean operating velocity

7.1.2 Radial dynamic limit load F_r perm

When selecting the product it is necessary to insure that no loading condition will exceed the allowable load.

8. Bearing handling

8.1 Storage

The bearings should be stored:

- in dry, clean rooms with the temperature as constant as possible
- at a relative humidity of max. 65%.

The storage period for greased and sealed bearings is limited by the shelf life of the grease.

8.2 Removal from packaging

Perspiration from handling leads to corrosion. Hands should be kept clean and dry and gloves worn if necessary.

Bearings should only be removed from their original packaging immediately before assembly.

If only a few bearings are taken out of a multi-piece package preserved by volatile corrosion inhibitor paper, the package must be closed again immediately

- the protective vapour phase is only effective when the package is closed
- the bearings which have been taken out must be greased or oiled immediately.



9. Allowable speed

As bearing speed increases, the temperature of the bearing also increases due to friction heat generated in the bearing interior. If the temperature continues to rise and exceeds certain limits, the efficiency of the lubricant start to fail down drastically, and the bearing can no longer continue to operate in a stable manner. Therefore, the maximum speed at which it is possible for the bearing to continuously operate without the generation of excessive heat beyond specified limits, is called the allowable speed (r/min). The allowable speed of a bearing depends on the type of bearing, bearing dimensions, type of cage, load, lubricating conditions, and cooling conditions.

The allowable speeds listed in the bearing tables for grease and oil lubrication are for **KSM** track roller under normal operating conditions, correctly installed, using the suitable lubricants with adequate supply and proper maintenance. Moreover, these values are based on normal load conditions ($P \leq 0.09C$, $F_a/F_r \leq 0.3$). For track roller with contact seals, the allowable speed is determined by the peripheral lip speed of the seal.

For track roller to be used under heavier than normal load conditions, the allowable speed values listed in the bearing tables must be multiplied by an adjustment factor. The adjustment factors f_L and f_C are given in Figs. 9.1 and 9.2.

Under such high speed operating conditions, when special care is taken, the standard allowable speeds given in the bearing tables can be adjusted upward. The maximum speed adjustment values, \sqrt{B} , by which the bearing table speeds can be multiplied, are shown in Table 9.1. However, for any application requiring speeds in excess of the standard allowable speed, please consult **KSM** Engineering.

Fig.9.1 Value of adjustment factor f_L depends on bearing load

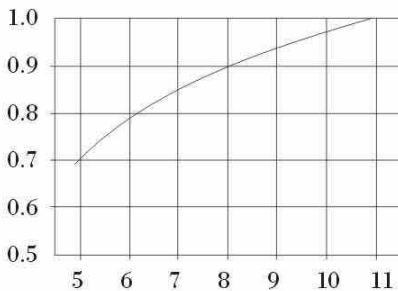

Fig.9.2 Value of adjustment factor f_C depends on combined load

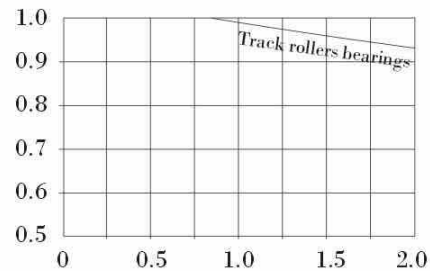

Table 9.1 Adjustment factor, f_B , for allowable number of revolutions

| Type of bearing | Adjustment factor f_B |
|------------------------|-------------------------|
| Track rollers bearings | 2.0 |



Track Roller Bearings



PRODUCT INFORMATION

P184 - 187



LR 2.., LR 2..RRU

P184



LR 52..

P185



LR 53..

P186



LFR..2Z, LFR..2RS

P187

Track roller bearings double row series LR..

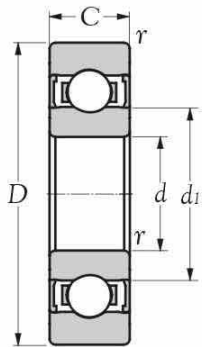

Type LR 2..X-2RSR
(Contact, double seals)

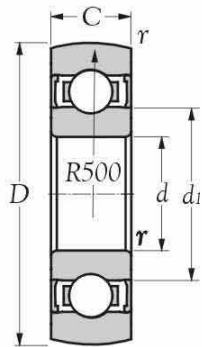

Type LR 2..2RSR
(Contact, double seals)

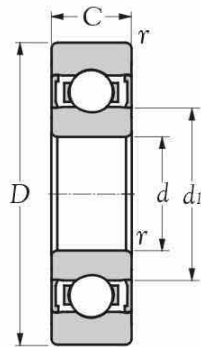

Type LR 2..X-2RS
(Light-contact, double seals)

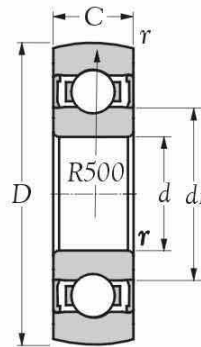

Type LR 2..2RS
(Light-contact, double seals)

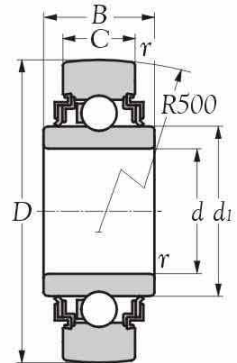

Type LR 2..RRU
(Contact, double seals)

| Inner bore <i>d</i> mm | Bearing number | | Boundary dimensions | | | | | Basic load ratings | | Limiting speeds | | Weight kg. |
|------------------------------|----------------|-------------|---------------------|----------|----------------------|----------------------|----------|---------------------|--------------------------------|-----------------|-----|---------------|
| | | | <i>D</i> | <i>C</i> | <i>r_s</i> | <i>d₁</i> | <i>B</i> | dynamic <i>C</i> | static <i>C₀</i> | grease rpm | oil | |
| | | | mm | | | | | N | | | | |
| 10 | LR 200 X-2RS | LR 200 2RS | 32 | 9 | 0.6 | 15.4 | - | 4,200 | 2,050 | 13,000 | - | 0.050 |
| 12 | LR 201 X-2RSR | LR 201 2RSR | 35 | 10 | 0.6 | 17.1 | - | 5,500 | 2,600 | 15,000 | - | 0.050 |
| 15 | LR 202 X-2RSR | LR 202 2RSR | 40 | 11 | 0.6 | 20.0 | - | 6,700 | 3,150 | 14,000 | - | 0.070 |
| 17 | LR 203 X-2RSR | LR 203 2RSR | 47 | 12 | 0.6 | 22.5 | - | 9,100 | 4,200 | 11,000 | - | 0.110 |
| 20 | LR 204 X-2RSR | LR 204 2RSR | 52 | 14 | 1.0 | 26.5 | - | 11,800 | 5,400 | 10,000 | - | 0.150 |
| 25 | LR 205 X-2RSR | LR 205 2RSR | 62 | 15 | 1.0 | 30.3 | - | 14,900 | 6,800 | 9,000 | - | 0.230 |
| 30 | LR 206 X-2RS | LR 206 2RS | 72 | 16 | 1.0 | 37.4 | - | 20,800 | 9,200 | 5,500 | - | 0.330 |
| 35 | LR 207 X-2RS | LR 207 2RS | 80 | 17 | 1.1 | 42.4 | - | 26,100 | 11,400 | 4,500 | - | 0.400 |
| 45 | LR 209 X-2RS | LR 209 2RS | 90 | 19 | 1.1 | 53.2 | - | 30,300 | 13,100 | 3,600 | - | 0.450 |
| 12 | LR 201 RRU | - | 35 | 10 | 0.6 | 18.5 | 15.0 | 5,500 | 3,000 | 15,000 | - | 0.070 |
| 15 | LR 202 RRU | - | 40 | 11 | 0.6 | 21.5 | 14.4 | 6,700 | 3,500 | 14,000 | - | 0.080 |

Note: 1) X: Cylindrical outside surface.

2) 2RS: Lip seals on both sides, giving axial sealing action.

3) 2RSR: Lip seals on both sides, giving radial sealing action.

Track roller bearings double row series LR 52..

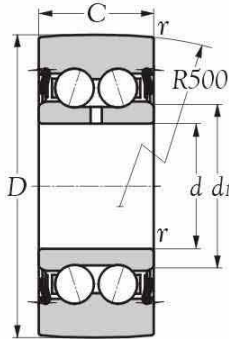

Type LR 52..2RS
(Light-contact, double seals)

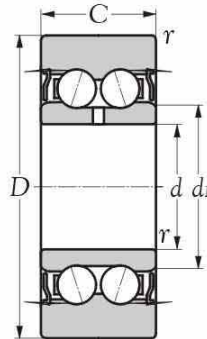

Type LR 52..X-2Z
(Double shields)

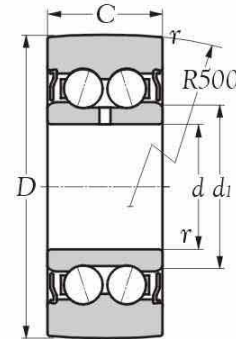

Type LR 52..2Z
(Double shields)

| Inner bore <i>d</i> mm | Bearing number | | Boundary dimensions | | | | Basic load ratings | | Limiting speeds | | Weight kg. |
|------------------------------|----------------|------------|---------------------|----------|----------------------|----------------------|---------------------|--------------------------------|-----------------|------------|---------------|
| | | | <i>D</i> | <i>C</i> | <i>r_s</i> | <i>d₁</i> | dynamic <i>C</i> | static <i>C₀</i> | grease rpm | oil rpm | |
| 10 | LR 5200 2RS | - | 32 | 14.0 | 0.6 | 15.4 | 6,500 | 3,900 | 8,000 | - | 0.070 |
| 12 | LR 5201 2RS | - | 35 | 15.9 | 0.6 | 17.1 | 8,500 | 4,900 | 7,500 | - | 0.080 |
| 15 | LR 5202 2RS | - | 40 | 15.9 | 0.6 | 20.0 | 10,100 | 5,900 | 7,000 | - | 0.110 |
| 17 | LR 5203 2RS | - | 47 | 17.5 | 0.6 | 22.5 | 13,700 | 7,800 | 5,500 | - | 0.170 |
| 20 | LR 5204 2RS | - | 52 | 20.6 | 1.0 | 26.5 | 17,700 | 10,000 | 5,000 | - | 0.230 |
| 25 | LR 5205 2RS | - | 62 | 20.6 | 1.0 | 30.3 | 22,000 | 12,400 | 4,500 | - | 0.340 |
| 30 | LR 5206 2RS | - | 72 | 23.8 | 1.0 | 37.4 | 30,700 | 20,400 | 3,500 | - | 0.510 |
| 35 | LR 5207 2RS | - | 80 | 27.0 | 1.1 | 42.4 | 39,400 | 21,300 | 2,800 | - | 0.660 |
| 40 | LR 5208 2RS | - | 85 | 30.2 | 1.1 | 48.4 | 45,500 | 24,300 | 2,500 | - | 0.750 |
| 10 | LR 5200 X-2Z | LR 5200 2Z | 32 | 14.0 | 0.6 | 15.4 | 6,500 | 3,900 | 11,000 | - | 0.070 |
| 12 | LR 5201 X-2Z | LR 5201 2Z | 35 | 15.9 | 0.6 | 17.1 | 8,500 | 4,900 | 10,000 | - | 0.080 |
| 15 | LR 5202 X-2Z | LR 5202 2Z | 40 | 15.9 | 0.6 | 20.0 | 10,100 | 5,900 | 10,000 | - | 0.110 |
| 17 | LR 5203 X-2Z | LR 5203 2Z | 47 | 17.5 | 0.6 | 22.5 | 13,700 | 7,800 | 7,500 | - | 0.170 |
| 20 | LR 5204 X-2Z | LR 5204 2Z | 52 | 20.6 | 1.0 | 26.5 | 17,700 | 10,000 | 7,000 | - | 0.230 |
| 25 | LR 5205 X-2Z | LR 5205 2Z | 62 | 20.6 | 1.0 | 30.3 | 22,000 | 12,400 | 6,500 | - | 0.340 |
| 30 | LR 5206 X-2Z | LR 5206 2Z | 72 | 23.8 | 1.0 | 37.4 | 30,700 | 20,400 | 5,000 | - | 0.510 |
| 35 | LR 5207 X-2Z | LR 5207 2Z | 80 | 27.0 | 1.1 | 42.4 | 39,400 | 21,300 | 3,900 | - | 0.660 |
| 40 | LR 5208 X-2Z | LR 5208 2Z | 85 | 30.2 | 1.1 | 48.4 | 45,500 | 24,300 | 3,500 | - | 0.750 |

Note: 1) X: Cylindrical outside surface.
 2) 2RS: Lip seals on both sides, giving axial sealing action.
 3) 2Z: Sealing shields on both sides



Track roller bearings double row series LR 53..

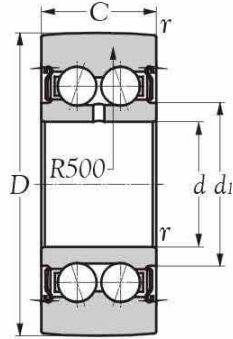

Type LR 53..2RS
(Light-contact, double seals)

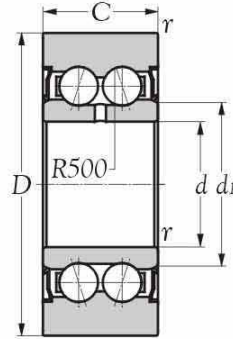

Type LR 53..2Z
(Double shields)

| Inner bore d mm | Bearing number | Boundary dimensions | | | | Basic load ratings | | Limiting speeds | | Weight kg(s)- |
|-------------------------|------------------------|---------------------|------|-------|-------|--------------------|-----------------|-----------------|-----|------------------|
| | | D | C | r_s | d_1 | dynamic C | static C_0 | grease rpm | oil | |
| 17 | LR 5303 2RS | 52 | 22.2 | 1.0 | 23.5 | 19,300 | 10,600 | 4,700 | - | 0.210 |
| 20 | LR 5304 2RS LR 5304 2Z | 62 | 22.2 | 1.1 | 29.0 | 25,100 | 13,800 | 4,500 | - | 0.340 |
| 25 | LR 5305 2RS LR 5305 2Z | 72 | 25.4 | 1.1 | 34.4 | 34,300 | 18,600 | 3,900 | - | 0.500 |
| 30 | LR 5306 2RS LR 5306 2Z | 80 | 30.2 | 1.1 | 41.4 | 47,200 | 25,200 | 3,100 | - | 0.670 |
| 35 | LR 5307 2RS LR 5307 2Z | 90 | 34.9 | 1.5 | 47.7 | 59,800 | 31,400 | 2,500 | - | 0.970 |
| 40 | LR 5308 2RS LR 5308 2Z | 100 | 36.5 | 1.5 | 52.4 | 78,000 | 39,900 | 2,300 | - | 1.200 |

Note: 1) 2RS: Lip seals on both sides, giving axial sealing action.
2) 2Z: Sealing shields on both sides.

Track roller bearings double row series LFR..

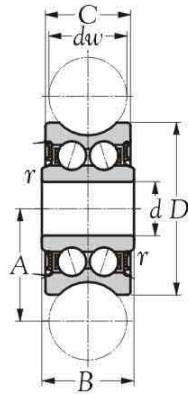

Type LFR..2RS
(Light-contact, double seals)

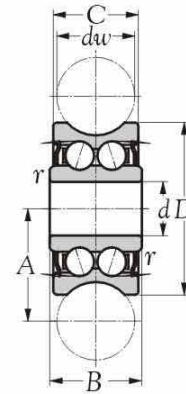

Type LFR..2Z
(Double shields)

| Inner bore <i>d</i> mm | Bearing number | | Boundary dimensions | | | | | | Basic load ratings | | Limiting speeds | | Weight kg(s). |
|------------------------------|-----------------|----------------|----------------------|----------|----------|----------|----------|----------------------|---------------------|--------------------------------|-----------------|-------|------------------|
| | | | <i>d_w</i> | <i>D</i> | <i>C</i> | <i>B</i> | <i>A</i> | <i>r_s</i> | dynamic <i>C</i> | static <i>C₀</i> | grease rpm | oil | |
| | | | mm | | | | | | N | | | | |
| 4 | LFR 50/4-4 2RS | LFR 50/4-4 2Z | 4 | 13.0 | 6.0 | 7.0 | 7.55 | 0.2 | 1050 | 850 | 1150 | 1600 | 0.007 |
| 5 | LFR 50/5-4 2RS | LFR 50/5-4 2Z | 4 | 16.0 | 7.0 | 8.0 | 9.00 | 0.2 | 1200 | 860 | 1300 | 1780 | 0.009 |
| 5 | LFR 50/5-6 2RS | LFR 50/5-6 2Z | 6 | 17.0 | 7.0 | 8.0 | 10.50 | 0.2 | 1270 | 820 | 1300 | 1780 | 0.010 |
| 8 | LFR 50/8-6 2RS | LFR 50/8-6 2Z | 6 | 24.0 | 11.0 | 11.0 | 14.00 | 0.3 | 3670 | 2280 | 1300 | 4560 | 0.020 |
| 12 | LFR 5201-10 2RS | LFR 5201-10 2Z | 10 | 35.0 | 15.9 | 15.9 | 20.65 | 0.3 | 8500 | 5100 | 5100 | 10200 | 0.080 |
| 12 | LFR 5301-10 2RS | LFR 5301-10 2Z | 10 | 42.0 | 19.0 | 19.0 | 24.00 | 0.6 | 13000 | 7700 | 7500 | 14200 | 0.100 |
| 15 | LFR 5302-10 2RS | LFR 5302-10 2Z | 10 | 47.0 | 19.0 | 19.0 | 26.65 | 1.0 | 16200 | 9200 | 6200 | 18400 | 0.170 |
| 12 | LFR 5201-12 2RS | LFR 5201-12 2Z | 12 | 35.0 | 15.9 | 15.9 | 21.75 | 0.3 | 8400 | 5000 | 5100 | 10000 | 0.085 |
| 12 | LFR 5201-14 2RS | LFR 5201-14 2Z | 14 | 39.9 | 18.0 | 20.0 | 24.00 | 0.3 | 8900 | 5000 | 6700 | 12100 | 0.095 |
| 20 | LFR 5204-16 2RS | LFR 5204-16 2Z | 16 | 52.0 | 20.6 | 22.6 | 31.50 | 0.6 | 16800 | 9500 | 12100 | 16600 | 0.230 |
| 25 | LFR 5206-20 2RS | LFR 5206-20 2Z | 20 | 72.0 | 23.8 | 25.8 | 41.00 | 0.6 | 29500 | 16600 | 20700 | 33200 | 0.250 |
| 25 | LFR 5206-25 2RS | LFR 5206-25 2Z | 25 | 72.0 | 23.8 | 25.8 | 43.50 | 0.6 | 29200 | 16400 | 23100 | 32800 | 0.250 |
| 30 | LFR 5207-30 2RS | LFR 5207-30 2Z | 30 | 80.0 | 27.0 | 29.0 | 51.00 | 1.0 | 38000 | 20800 | 21400 | 36200 | 0.660 |
| 40 | LFR 5208-40 2RS | LFR 5208-40 2Z | 40 | 98.0 | 36.0 | 38.0 | 62.50 | 1.0 | 54800 | 29000 | 55000 | 58000 | 1.360 |
| 40 | LFR 5308-50 2RS | LFR 5308-50 2Z | 50 | 110.0 | 44.0 | 46.0 | 72.50 | 1.1 | 53000 | 39500 | 69000 | 79000 | 1.400 |

Remark: * Standard with lubrication hole on inner ring

- 1) 2Z: Sealing shields on both sides.
- 2) 2RS: Lip seals on both sides, giving axial sealing action.





<http://www.minamiguchi.co.jp>

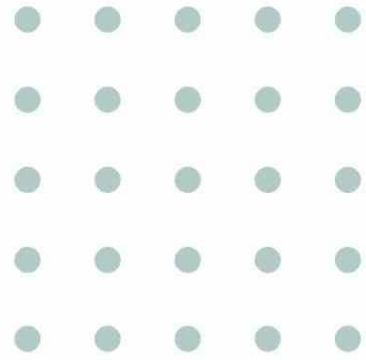

南口精工株式会社

